

Conductive Polymer Capacitors

General Catalog 2022



**IN Your
Innovation**

Electrolytic capacitors with conductive polymer to meet the needs of all electronic equipments in the world

SP-Cap, POSCAP, OS-CON, Hybrid

By using a high conductive polymer as the electrolyte, it has achieved in lower equivalent series resistance that could help and contribute excellent noise reduction and smoothing to an electrical fluctuation. In addition to that, that has excellence in product operational life, reliability and heat resistance.

Features

* For details, see the right page

Low ESR

- Suitable as a decoupling capacitor to remove noises, because its impedance has ideal frequency characteristics.
- Suitable as a smoothing capacitor for switching power supply or a backup capacitor for CPU because it allows large ripple current.
- Suitable as a backup capacitor for the circuits that consumes large current at a high speed.

Temperature characteristics

- ESR has stable characteristics at when operating between -55°C to 150°C, suitable for applications used at low temperatures (under 0 °C).

Long life

Super low ESR

Small size / Low profile

Rush current resistance characteristics

Wide capacitance range

High voltage High reliability

Environmental responsibility

Environmental responsibility

Principle

Industrial Solutions Company Group, Panasonic Corporation, Fulfills both environmental contribution and business growth, takes care of biodiversity, and contributes to create harmonization of environment, economy and society and to achieve a sustainable society.

RoHS compliance

All capacitors comply with RoHS directive (2011/65/EU) and (EU)2015/863.

Restricted Substance

Restricted substances of RoHS directive

- ◆ Cadmium(Cd) and it's compounds
- ◆ Lead(Pb) and it's compounds
- ◆ Mercury(Hg) and it's compounds
- ◆ Hexavalent chromium(Cr+6)
- ◆ Polybrominated biphenyls(PBBs)
- ◆ Polybrominated diphenyl ethers(PBDEs)
- ◆ Bis(2-ethylhexyl) phthalate (DEHP)
- ◆ Benzyl butyl phthalate (BBP)
- ◆ Dibutyl phthalate (DBP)
- ◆ Diisobutyl phthalate (DIBP)

Lead-free stance

All complete parts and homogenous materials of capacitors are lead-free. (JEITA, PHASE3)

ISO/IATF (ISO/TS) Certified

(1)Quality Approval

Factory (Site)	Applicable standard	Organization	Certificate number	Acquisition years
●Uji factory (Kyoto)	ISO 9001 :2015	JQA	JQA-2524	1998.07.31
	IATF 16949:2016	JQA	JQA-AU0162-14	2016.09.13
	●Yamaguchi factory (Yamaguchi)	ISO 9001 :2015	JQA	JQA-2524
	IATF 16949:2016	JQA	JQA-AU0162-1	2007.02.23
●Panasonic Industrial Devices Saga Co., Ltd. (Former:SAGA SANYO Industries Co., Ltd.)(Saga)	ISO 9001 :2015	JQA	JQA-2524	1998.07.31
	IATF 16949:2016	JQA	JQA-AU0162-10	2006.07.31
	●PIDSG (Singapore)	ISO 9001 :2015	BSI	FM 612824
●PICID (Former: SJC) (Indonesia)	ISO 9001 :2015	SGS	ID17/03853, ID19/04586	2006.03.26
	IATF 16949:2016	SGS	ID19/04510	2011.03.01

(2)Environment Approval

Factory (Site)	Applicable standard	Organization	Certificate number	Acquisition years
●Uji factory (Kyoto)	ISO 14001 :2015	JACO	EC10J0027	1996.12.26
	●Yamaguchi factory (Yamaguchi)	ISO 14001 :2015	JACO	EC10J0027
●Panasonic Industrial Devices Saga Co., Ltd. (Former:SAGA SANYO Industries Co., Ltd.)(Saga)	ISO 14001 :2015	JACO	EC10J0027	1998.03.10
	●PIDSG (Singapore)	ISO 9001 :2015	AJA	AJA98/1151
●PICID (Former: SJC) (Indonesia)	ISO 14001 :2015	SGS	16/03617	2010.02.15
	ISO 14001 :2015	SGS	17/04090	2011.11.04

Conductive Polymer Capacitors

General Catalog

INDEX

- P4 Notices / Items to be observed
- P5 Polymer Capacitor of Panasonic
- P7 SP-Cap/POSCAP Voltage & Capacitance
- P9 OS-CON/Hybrid Voltage & Capacitance

Conductive Polymer Aluminum Electrolytic Capacitors

SP-Cap™



- Long life
Endurance 125 °C 3000 h
- Super low ESR
3 mΩ max.
- Small size / Low profile
Height 1.0 mm max.
- Wide capacitance range
10 μF to 820 μF
- Environmental responsibility
RoHS compliance
Halogen free

Conductive Polymer Tantalum Solid Capacitors

POSCAP™



- Long life
Endurance 125 °C 1000 h
- Super low ESR
5 mΩ max.
- Small size / Low profile
L3.5 x W2.8 x H1.1 mm
- Wide capacitance range
3.9 μF to 1500 μF
- Rush current resistance characteristics
The rush current is guaranteed at 20 A.
- High voltage / High reliability
35 V max.
- Environmental responsibility
RoHS compliance
Halogen free

Conductive Polymer Aluminum Solid Capacitors

OS-CON™

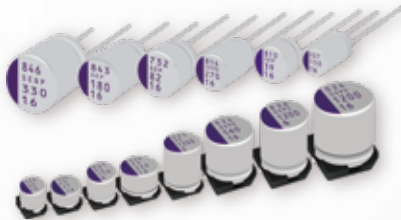

- Long life
Endurance 105 °C 20000 h
Endurance 125 °C 2000 h
- Low ESR
5 mΩ max.
- Wide capacitance range
3.3 μF to 2700 μF
- High voltage / High reliability
100 V max.
- Environmental responsibility
RoHS compliance
Halogen free

Conductive Polymer Hybrid Aluminum Electrolytic Capacitors

Hybrid



- Long life
Endurance 125 °C 4000 h
Endurance 135 °C 4000 h
Endurance 145 °C 2000 h
Endurance 150 °C 1000 h
- Wide capacitance range
10 μF to 1000 μF
- High voltage / High reliability
80 V max.
- Environmental responsibility
RoHS compliance

SP-Cap

Selection guide	P13	Guidelines and Precautions
	P16	Mounting specifications Packing specifications
Surface mount type	P17	Line-up
	P18	Series system diagram
	P19	Products list
	P21	CS/CT/CX
	P23	SX
	P25	GX/GX-L
	P26	LX
	P27	SR/LR/SS/LS/ST/LT
	P29	GY
	P30	CY/SY
	P31	JX
	P33	HX
	P35	Catalog EOL models

POSCAP

Selection guide	P41	Guidelines and Precautions
	P43	Mounting specifications Packing specifications
Surface mount type	P45	Line-up
	P47	Series system diagram Size list
	P49	Products list
	P51	TPG
	P52	TPS
	P53	TPSF
	P54	TQS
	P55	TPE
	P59	TPF
	P61	TQC
	P63	TA
	P64	TV
	P65	TH
P66	TPB	
P67	TC	
P69	TDC	
P70	TPC	
P71	Catalog Deletion models	
P72	Catalog EOL models	

OS-CON

Selection guide	P75	Guidelines and Precautions
	P78	Mounting specifications Packing specifications
Surface mount type	P81	Line-up
	P83	Series system diagram Size list
	P85	Products list
	P87	SVT
	P89	SVPT
	P90	SVF
	P91	SVPK
	P93	SXV
	P94	SVPG
	P95	SVPF
	P96	SVPA
	P97	SVPC
	P99	SVPB
P100	SVPD	
P101	SVPS	
P103	SVPE	
P104	SVQP	
P105	SVP	
Radial lead type	P107	SEK
	P108	SEF
	P109	SEPG
	P110	SXE
	P111	SEPF
	P113	SEPC
	P115	SEQP
P117	SEP	
P119	Catalog EOL models	

Hybrid

Selection guide	P123	Guidelines and Precautions
	P127	Mounting specifications Packing specifications
Surface mount type	P130	Line-up
	P131	Series system diagram
	P132	Products list
	P133	ZA
	P135	ZC
	P137	ZK
	P139	ZKU
	P141	ZT
	P143	ZS
	P145	ZSU
	P147	ZU
	P149	ZE
	P151	ZF
Radial lead type	P153	ZA-A
	P155	ZC-A
	P157	ZK-A
	P159	ZKU-A
	P161	ZT-A
	P163	ZS-A
	P165	ZSU-A
P167	ZE-A	
P169	ZF-A	

Guidelines and precautions regarding the technical information and use of our products described in this online catalog.

- If you want to use our products described in this online catalog for applications requiring special qualities or reliability, or for applications where the failure or malfunction of the products may directly jeopardize human life or potentially cause personal injury (e.g. aircraft and aerospace equipment, traffic and transportation equipment, combustion equipment, medical equipment, accident prevention, anti-crime equipment, and/or safety equipment), it is necessary to verify whether the specifications of our products fit to such applications. Please ensure that you will ask and check with our inquiry desk as to whether the specifications of our products fit to such applications use before you use our products.
- The quality and performance of our products as described in this online catalog only apply to our products when used in isolation. Therefore, please ensure you evaluate and verify our products under the specific circumstances in which our products are assembled in your own products and in which our products will actually be used.
- The products and product specifications described in this online catalog are subject to change for improvement without prior notice. Therefore, please be sure to request and confirm the latest product specifications which explain the specifications of our products in detail, before you finalize the design of your applications, purchase, or use our products.
- The technical information in this online catalog provides examples of our products' typical operations and application circuits. We do not guarantee the non-infringement of third party's intellectual property rights and we do not grant any license, right, or interest in our intellectual property.
- If any of our products, product specifications and/or technical information in this online catalog is to be exported or provided to non-residents, the laws and regulations of the exporting country, especially with regard to security and export control, shall be observed.

< Regarding the Certificate of Compliance with the EU RoHS Directive / REACH Regulations >

- The switchover date for compliance with the RoHS Directive/REACH Regulations varies depending on the part number or series of our products.
- When you use the inventory of our products for which it is unclear whether those products are compliant with the RoHS Directive/REACH Regulation, please select "Sales Inquiry" in the website inquiry form and contact us.

We do not take any responsibility for the use of our products outside the scope of the specifications, descriptions, guidelines and precautions described in this online catalog.

Notices / Items to be observed

Notices

Applicable laws and regulations

- This product complies with the RoHS Directive (Restriction of the use of certain Hazardous substances in electrical and electronic equipment (DIRECTIVE 2011/65/EU) and (EU)2015/863.
- No Ozone Depleting Chemicals(ODC's), controlled under the Montreal Protocol Agreement, are used in producing this product.
- We do not use PBBs or PBDEs as brominated flame retardants.
- Export procedure which followed export related regulations, such as foreign exchange and a foreign trade method, on the occasion of export of this product.
- These products are not dangerous goods on the transportation as identified by UN(United Nations) numbers or UN classification.

Limited applications

- This capacitor is designed to be used for electronics circuits such as audio/visual equipment, home appliances, computers and other office equipment, optical equipment, measuring equipment.
- An advanced specification must be signed individually for high-reliability use that might threaten human life or property due to a malfunction of the capacitor.

Intellectual property rights and licenses

- The technical information in this specification provides examples of our products' typical operations and application circuits. We do not guarantee the non-infringement of third party's intellectual property rights and we do not grant any license, right, or interest in our intellectual property.

Items to be observed

For specification

- This specification guarantees the quality and performance of the product as individual components. The durability differs depending on the environment and the conditions of usage. Before use, check and evaluate their compatibility with actual conditions when installed in the products. When safety requirements cannot be satisfied in your technical examination, inform us immediately.
- Do not use the products beyond the specifications described in this document.

When using this capacitor in a product where safety is critical

- Though, we are confident in the product quality, we cannot deny the possibility that they could fail due to short or open circuit.
- Install the following systems for a fail-safe design to ensure safety if these products are to be used in equipment where a defect in these products may cause the loss of human life or other signification damage, such as damage to vehicles (automobile, train, vessel), traffic lights, medical equipment, aerospace equipment, electric heating appliances, combustion/gas equipment, rotating rotating equipment, and disaster/crime prevention equipment.
 - The system is equipped with a protection circuit and protection device.
 - The system is equipped with a redundant circuit or other system to prevent an unsafe status in the event of a single fault.

Conditions of use

- Before using the products, carefully check the effects on their quality and performance, and determined whether or not they can be used. These products are designed and manufactured for general-purpose and standard use in general electronic equipment. These products are not intended for use in the following special conditions.
 - (1) In liquid, such as Water, Oil, Chemicals, or Organic solvent.
 - (2) In direct sunlight, outdoors, or in dust.
 - (3) In vapor, such as dew condensation water of resistive element, or water leakage, salty air, or air with a high concentration corrosive gas, such as Cl₂, H₂S, NH₃, SO₂, or NO_x.
 - (4) In an environment where strong static electricity or electromagnetic waves exist.
 - (5) Mounting or placing heat-generating components or inflammables, such as vinyl-coated wires, near these products.
 - (6) Sealing or coating of these products or a printed circuit board on which these products are mounted, with resin and other material.
 - (7) Using resolvent, water or water-soluble cleaner for flux cleaning agent after soldering.
(In particular, when using water or a water-soluble cleaning agent, be careful not to leave water residues)
 - (8) Using in the atmosphere which strays Acid or alkaline.
 - (9) Using in the atmosphere which there are excessive vibration and shock.
 - (10) Using in the atmosphere where there are low pressure or decompression.
- Please arrange circuit design for preventing impulse or transitional voltage.
Do not apply voltage, which exceeds the full rated voltage when the capacitors receive impulse voltage, instantaneous high voltage, high pulse voltage etc.
- Electrolyte is used in the products. Therefore, misuse can result in rapid deterioration of characteristics and functions of each product. Electrolyte leakage damages printed circuit and affects performance, characteristics, and functions of customer system.

Conductive polymer capacitor of Panasonic

SP-Cap

Conductive Polymer Aluminum Electrolytic Capacitors (Stack Type)

Super Low ESR

Low profile

Large capacitance

POSCAP

Conductive Polymer Tantalum Solid Capacitors (Sintered Type)

Low ESR

Small size

Large capacitance

OS-CON

Conductive Polymer Aluminum Solid Capacitors (Wound Type)

Low ESR

High voltage

Large capacitance

Hybrid

Conductive Polymer Hybrid Aluminum Electrolytic Capacitors (Wound Type)
Conductive Polymer+Electrolyte

Low ESR

High voltage

High reliability

Characteristics Portfolio

Full coverage of the capacitor conductive market

Voltage vs. Capacitance

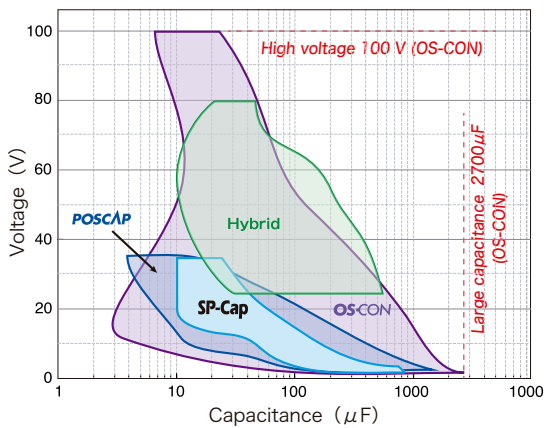

Capacitance vs. ESR

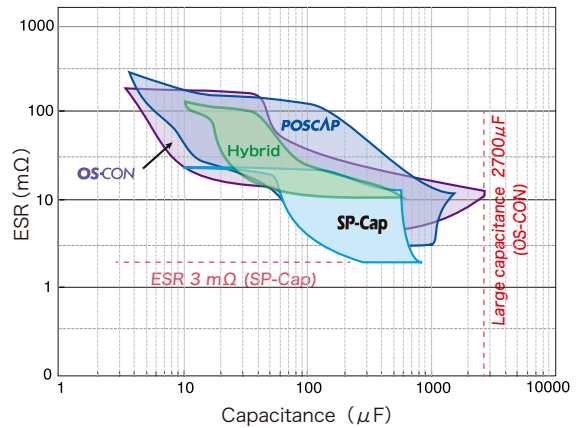

Basic structure

SP-Cap

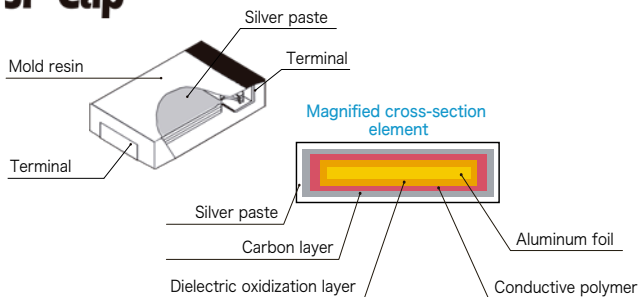

POSCAP

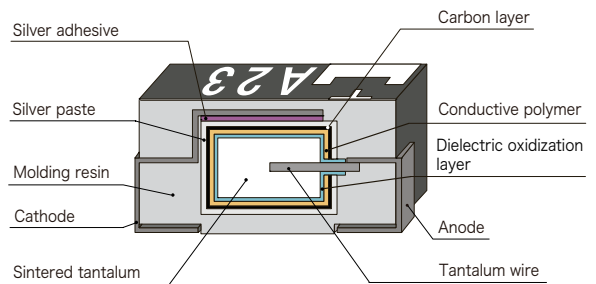

OS-CON Hybrid

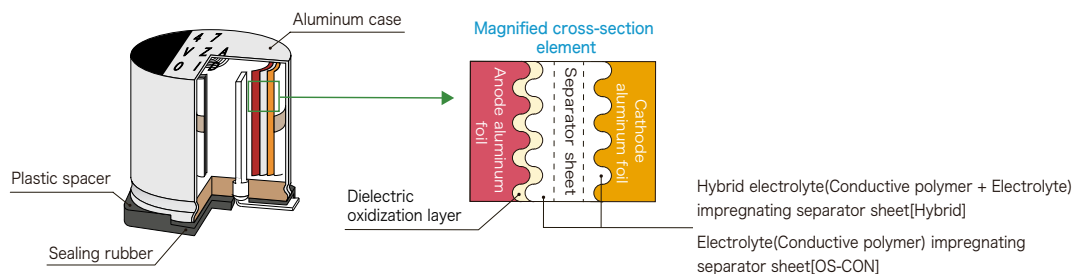

Total Solutions

Examples of common use case four conductive products

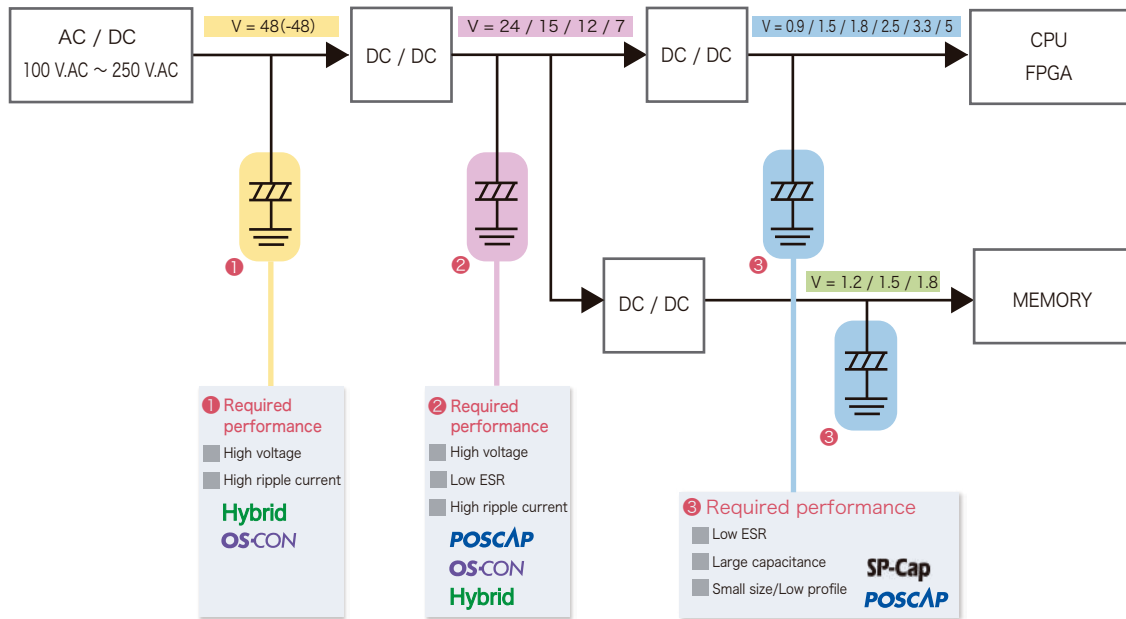

● You can select the optimal article from "size form and total cost" etc. besides an electrical property.

Application

	SP-Cap	POSCAP	OS-CON	Hybrid
Laptop computer	●	●		
Desktop computer			●	●
Audio/Visual	●	●	●	●
Server	●	●	●	●
Communications infrastructure	●	●	●	●
SSD, HDD		●		
Automotive		● [※]		●
Home appliance			●	●
Industry	Industrial equipment	●	●	●
	Industrial robot		●	●
	Drone etc.	●	●	

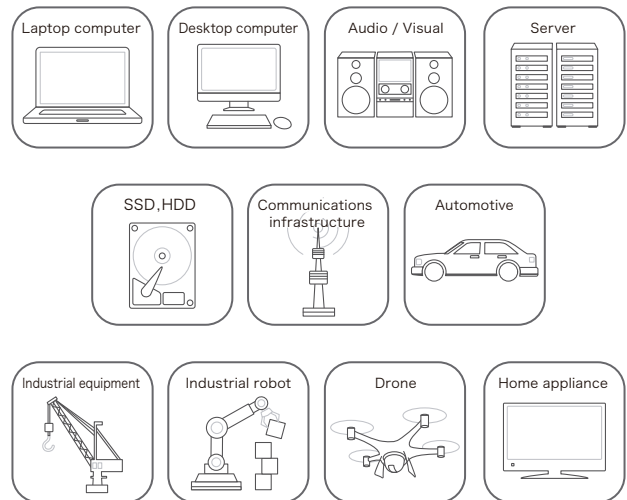

※ This product is not intended for use in any driving application or any other critical functions that affect passenger safety (e.g. Powertrain, ABS, Engine ECU, Airbag, etc.) If the intended use of TA/TV series products is for use in other automotive related applications, please contact our sales team. All requests are subject to approval. ● Main market

Voltage & Capacitance

SP-Cap POSCAP

Series(ESR mΩ) [Size](Ripple A rms)

V	μF	3.9	4.7	5.6	8.2	10	15	22	33	47	56	68	82	100
2.0														
2.5														
4.0												TPB [B2] (70)(1.1)	SX [D] (9)(6.3)	SX [D] (9)(6.3) TPE [B2] (70/40/35)(3/1/0.95) TA [B2] (70)(1.1)
6.3									TPB [B2] (70)(1.1)	TA [B2] (70)(1.1) (55/70)(1.1/1.0)		CS [D] (15)(5.1)		CT [D] (15)(5.1)
												SR [D] (9)(6.3)	TPG [B1G] (9)(6.3)	CX [D] (15)(5.1)
8.0														
10								TPC [B1] (70)(1.0)		TPG [B1G] (70)(1.1)				
									TPB [B2] (70)(1.1)	CS [D] (40)(3.2)		CT [D] (40)(3.2)		CX [D] (40)(3.2)
12.5														
16														
20														
25														
35														

Size code

SP-Cap
LxWxH

D 7.3x4.3x1.0 max.
7.3x4.3x1.1
7.3x4.3x1.4

SR, LR
CS, SS, LS
CT, ST, LT

D

7.3x4.3x1.9
7.3x4.3x2.8
CX, SX, GX, LX, GX-L, HX
CY, SY, GY
(unit : mm)

POSCAP
LxWxH

B1, B1G, B1S 3.5x2.8x1.1
B2, B2S 3.5x2.8x1.9

Voltage (More than 16V) & Capacitance SMD type

Series [Size]
(ESR mΩ) (Ripple A rms)

Product of 105 °C

OS-CON Hybrid

V	μF	3.3	10	15	18	22	27	33	39	47	56	68	82	100	120
16		SVP [A5] (260)(0.66)		SVP [B6] (120)(1.02)		SVPS [B6] (90)(1.06) SVP [B6] (90)(1.06)		SVPB [C5] (40)(1.67)	SVPA [C6] (35)(2.04) SVP [C6] (24)(2.46)	SVPG [B45] (25)(3.2)	SVP [E7] (45)(1.89)	SVPC [C6] (30)(2.2) SVPC [C6] (25)(2.44)	SVPA [E7] (30)(2.76) SVPS [E7] (30)(2.76)	SVPC [C6] (24)(2.49) SVPS [F8] (35)(2.67)	SVPC [E7] (27)(2.9)
	20		SVPA [B6] (40)(1.7) SVP [B6] (120)(1.02)	SVPB [C5] (45)(2.0)		SVPA [C6] (35)(2.04) SVPB [C55] (35)(2.0) SVPS [C6] (60)(1.45) SVP [C6] (60)(1.45)	SVP [C6] (60)(1.45)	SVPG [B45] (27)(3.0) SVP [E7] (45)(1.89)		SVPA [E7] (33)(2.63) SVPS [E7] (45)(1.89) SVP [E7] (45)(1.89)	SVPF [B6] (30)(2.8) SVP [F8] (40)(2.4)	SVP [F8] (40)(2.4)			SVPE [I2] (24)(3.32)
25			SVPS [E7] (60)(1.5)	SVPG [B45] (30)(2.8)		ZA [C] (80)(0.9)	SVPF [B6] (40)(2.45)	ZA [C] (80)(0.9)		SVPF [C6] (30)(2.8) ZA [D] (50)(1.3)	SVPF [C6] (30)(2.8) ZA [D] (50)(1.3)			SVPF [E7] (28)(3.0)	SVPF [E7] (24)(3.2)
	35		ZA [C] (100)(0.9)			SVPF [C6] (35)(2.6) ZA [C] (100)(0.9)	ZA [D] (60)(1.3)	ZA [D] (60)(1.3)	SVPF [E7] (30)(2.8) SVPT [E7] (30)(2.8)	ZA [D] (60)(1.3)		ZA [D8] (35)(2.0)	SVPF [E12] (20)(4.0) SVPT [E12] (20)(4.0)	ZA [F] (27)(2.3)	SVPF [I2] (18)(4.4)
50			SVPF [C6] (40)(2.5) ZA [C] (120)(0.75)		SVPF [E7] (35)(2.7) SVPT [E7] (35)(2.7)	ZA [D] (80)(1.1)		ZA [D8] (40)(1.6)	SVPF [E12] (25)(3.8) SVPT [E12] (25)(3.8)	ZA [F] (30)(1.8)		SVPF [F12] (20)(4.3) SVPT [F12] (20)(4.3)		ZA [G] (26)(2.0)	
	63		ZA [D] (120)(1.0)			ZA [D8] (80)(1.55)		ZA [F] (40)(1.7)		ZA [F] (40)(1.7)	ZA [G] (30)(1.8)	ZA [G] (30)(1.8)		ZA [G] (30)(1.8)	
80						ZA [F] (45)(1.55)		ZA [G] (36)(1.7)		ZA [G] (36)(1.7)					

Product of 125 °C

V	μF	6.8	8.2	10	12	15	18	22	27	33	39	47	56	68	82	
16												SVQP [C6] (50)(0.512)				SVF [B6] (27)(0.94)
	20								SVQP [C6] (60)(0.459)				SVQP [E7] (45)(0.598)	SVF [B6] (30)(0.88)	SVPK [B6] (30)(0.88)	
25				SVPD [C6] (65)(0.474)				SVPD [E7] (48)(0.58)	SVF [B6] (40)(0.77)	SVPK [B6] (35)(0.82) ZC [C] (80)(0.55)	SVPD [F8] (45)(0.664)	SVF [C6] (30)(0.88) SVPD [E12] (30)(0.943) ZC [D] (50)(0.9)	SVF [C6] (30)(0.88) ZC [D] (50)(0.9)	ZK [D] (50)(1.3)	SVF [E7] (28)(0.94) SVPK [C6] (25)(0.96) SVPD [F12] (28)(1.202) ZK [D] (50)(1.3)	
	35		SVPD [E7] (70)(0.4)	ZC [C] (100)(0.55)			SVPD [F8] (60)(0.55)	SVF [C6] (35)(0.82) SVPK [B6] (35)(0.82)	ZC [D] (60)(0.9)	ZK [C] (100)(0.75)	SVF [E7] (30)(0.88) SVPD [F12] (30)(1.15)	SVPK [C6] (27)(0.93) ZC [D] (60)(1.2)	ZK [D] (60)(1.2)	ZC [D8] (35)(1.4) ZK [D] (60)(1.2)	SVF [E12] (20)(1.26) SVF [E7] (25)(0.96) SVT [E12] (20)(1.26)	
50			SVF [C6] (40)(0.79) SVPK [B6] (80)(0.55) ZC [C] (120)(0.5)			SVF [E7] (35)(0.85) SVT [E7] (35)(0.85)	SVPK [C6] (35)(0.82) ZC [D] (80)(0.75)		SVPK [E7] (35)(0.85) ZC [D8] (40)(1.1)	SVF [E12] (25)(1.2) ZC [D] (25)(1.2)		ZC [F] (30)(1.25)		SVF [F12] (20)(1.35) SVPK [E12] (25)(1.2) SVT [F12] (20)(1.35) ZC [F] (30)(1.25) ZT [F] (25)(2.7)		
	63		ZC [D] (120)(0.7)			SXV [E7] (60)(0.34)	ZC [D8] (80)(0.9)		SXV [E12] (25)(0.93) ZC [F] (40)(1.1) ZT [F] (32)(2.4)	SXV [E12] (25)(0.93) ZC [G] (30)(1.4) ZT [G] (25)(2.8)	SXV [E12] (25)(0.93) ZC [F] (40)(1.1)	ZT [F] (32)(2.4) ZC [G] (30)(1.4) ZT [G] (25)(2.8)	SXV [E12] (25)(0.93) ZC [G] (30)(1.4) ZT [G] (25)(2.8)	SXV [F12] (28)(1.03) ZC [G] (30)(1.4) ZT [G] (25)(2.8)	ZT [G] (25)(2.8) ZC [G] (30)(1.4)	
80					SXV [E7] (60)(0.34)		ZC [F] (45)(1.05)		SXV [E12] (35)(0.78) SXP [F8] (55)(0.66)	SXV [E12] (35)(0.78) ZC [G] (36)(1.36)		SXV [F12] (28)(0.98) ZC [G] (36)(1.36)		SXV [F12] (28)(0.98)		
	100	SXV [E7] (60)(0.34)				SXV [F8] (60)(0.83) SXP [E12] (40)(0.73)	SXV [F12] (30)(0.94) SXP [E12] (40)(0.73)	SXV [F12] (30)(0.94)	SXV [F12] (30)(0.94)							

Product of 145 °C

V	μF	33	56	68	82	100	150	220	270	330
25								ZE [F] (27)(0.7)		ZE [G] (20)(0.9)
35							ZE [F] (27)(0.7)		ZE [G] (20)(0.9)	
50			ZE [F] (30)(0.6)			ZE [G] (28)(0.8)				
63	ZE [F] (40)(0.6)	ZE [G] (30)(0.8)		ZE [G] (30)(0.8)						

Size load

OS-CON

B45	φ 5xL4.4	C6	φ 6.3xL5.9	E7	φ 8xL6.9	F8	φ 10xL7.9
B6	φ 5xL5.9	C65	φ 6.3xL6.4	E10	φ 8xL10.0	F10	φ 10xL10.0
		C10	φ 6.3xL9.9	E12	φ 8xL11.9	F12	φ 10xL12.6
		C10L	φ 6.3xL10.4				

(unit : mm)

V	μF	150	180	220	270	330	390	470	560	680	820	1000	1200
16		SVPC [E7] (22)(3.22)	SVPF [C6] (22)(3.3)	SVPG [C6] (14)(4.1)	SVPG [C8] (10)(5.08)	SVP [F12] (16)(4.72)		SVPE [F12] (10)(6.1)	SVPF [E12] (14)(4.95)	SVPG [E12] (8)(6.5)	SVPG [F10] (9)(5.7)	SVPF [F12] (12)(5.4)	SVPG [F12] (7)(7.0)
		SVP [F8] (30)(3.02)	SVPA [F8] (29)(3.43)		SVPG [C10] (8)(5.8)	SVPG [C10L] (6.5)(7.5)			SVPF [E10] (18)(3.9)			SVPF [F10] (16)(4.3)	
			SVPS [F8] (29)(3.43)		SVPF [E7] (22)(3.3)	SVPG [E7] (16)(4.1)			SVPG [E10] (10)(5.2)			SVPT [F12] (12)(5.4)	
			SVPE [C10] (11)(4.46)		SVPC [E12] (16)(4.07)				SVPT [E12] (14)(4.95)				
20		SVP [F8] (30)(3.02)	SVP [E12] (20)(3.64)										
		SVP [F12] (20)(4.32)	SVPF [E7] (25)(3.2)				SVPF [E12] (14)(4.95)		SVPF [F12] (12)(5.4)				
25		ZA [F] (27)(2.3)	SVPF [E12] (16)(4.65)	ZA [F] (27)(2.3)		SVPF [F12] (14)(5.0)							
			SVPT [E12] (16)(4.65)			SVPT [F12] (14)(5.0)							
35		ZA [F] (27)(2.3)		ZA [G] (20)(2.5)	ZA [G] (20)(2.5)								
50													
63													
80													

V	μF	100	120	150	180	220	270	330	390	470	560	680	1000	1200
16		SVPK [B6] (27)(0.94)			SVF [C6] (22)(1.04)	SVPK [C6] (22)(1.04)	SVF [E7] (22)(1.04)	SVPK [E7] (22)(1.04)			SVF [E12] (14)(1.56)	SVPK [E12] (14)(1.56)	SVF [F12] (12)(1.7)	SVPK [F12] (12)(1.7)
		SVT [C65] (24)(0.78)					SVT [E7] (22)(1.04)				SVT [E12] (14)(1.56)		SVT [F12] (12)(1.7)	SVT [F12] (12)(1.7)
20			SVF [C6] (25)(1.01)	SVPK [C6] (25)(1.01)	SVF [E7] (25)(1.01)	SVPK [E7] (25)(1.01)				SVF [E12] (14)(1.56)	SVPK [E12] (14)(1.56)	SVF [F12] (12)(1.7)	SVPK [F12] (12)(1.7)	
					SVT [E7] (25)(1.01)									
25		SVF [E7] (24)(1.01)	SVPK [E7] (24)(1.01)	ZK [D8] (30)(1.8)	SVF [E12] (16)(1.47)	ZC [F] (27)(1.6)	SVPK [E12] (16)(1.47)	SVF [F12] (14)(1.58)			SVPK [F12] (14)(1.59)	ZS [G16] (11)(4.0)	ZSU [G12] (14)(3.5)	ZSU [G16] (11)(4.0)
		SVT [E7] (24)(1.01)		ZC [F] (27)(1.6)	SVT [E12] (16)(1.47)	ZT [F] (22)(2.9)	ZK [F] (27)(2.0)	SVT [F12] (14)(1.58)			ZK [G] (20)(2.8)	ZKU [G] (20)(2.8)		
		ZC [D8] (30)(1.4)			ZKU [D8] (30)(1.6)			ZC [G] (20)(2.0)			ZS [G12] (14)(3.5)	ZU [G16] (8)(5.8)		
		ZKU [D] (50)(1.3)						ZT [G] (16)(3.5)			ZU [G12] (10)(5.0)			
35		ZK [D8] (35)(1.7)	SVF [F12] (18)(1.39)	ZC [F] (27)(1.6)	SVPK [E12] (20)(1.26)	ZC [G] (20)(2.0)	ZC [G] (20)(2.0)	SVPK [F12] (18)(1.39)	ZKU [G] (20)(2.8)		ZS [G16] (11)(4.0)		ZSU [G16] (11)(4.0)	
		ZC [F] (27)(1.6)	SVT [F12] (18)(1.39)	ZT [F] (22)(2.9)	ZK [F] (27)(2.0)	ZK [F] (27)(2.0)	ZT [G] (16)(3.5)	ZK [G] (20)(2.8)			ZU [G16] (9)(5.5)			
50		ZC [D8] (30)(1.4)	ZKU [D8] (30)(1.6)					ZS [G12] (14)(3.5)			ZSU [G12] (14)(3.5)			
		ZC [G] (28)(1.6)	SVPK [F12] (20)(1.35)	ZS [G12] (17)(3.2)	ZSU [G12] (17)(3.2)	ZS [G16] (13)(3.7)	ZSU [G16] (13)(3.7)							
63		ZT [G] (23)(2.9)	ZC [G] (28)(1.6)	ZU [G12] (12)(4.6)		ZU [G16] (10)(5.2)								
			ZT [G] (23)(2.9)											
80														
100														
63		SXV [F12] (29)(1.03)	ZSU [G12] (19)(3.0)	ZS [G16] (15)(3.5)	ZSU [G16] (15)(3.5)									
		ZS [G12] (19)(3.0)	ZU [G16] (10)(5.2)											
80														
100														

Product of 150 °C

V	μF	33	56	100	150	270
25					ZF [F] (27)(0.8)	ZF [G] (20)(1.0)
35				ZF [F] (30)(0.77)	ZF [G] (23)(0.95)	
50			ZF [F] (35)(0.7)	ZF [G] (28)(0.9)		
63		ZF [F] (40)(0.65)	ZF [G] (30)(0.84)			

Hybrid

(unit : mm)

C	φ 5xL5.8	D8	φ 6.3xL7.7	G	φ 10xL10.2
D	φ 6.3xL5.8	F	φ 8xL10.2	G16	φ 10xL16.5

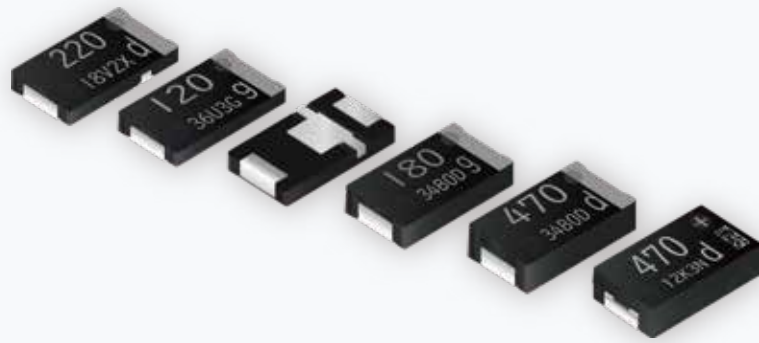

Conductive Polymer Aluminum Electrolytic Capacitors

SP-Cap™

INDEX

Guidelines and Precautions	P13
Mounting specifications / Packing specifications	P16
Selection guide	P17
Products list	P21
Catalog EOL models / Not recommended for new design	P35

SP-Cap

Guidelines and Precautions	Line-up
Mounting specifications	Series system diagram
Packing specifications	Products list
Selection guide	CS/CT/CX
	SX
	GX/GX-L
	LX
	SR/LR/SS/LS/ST/LT
	GY
	CY/SY
Surface mount type	JX
	HX
Catalog EOL models	

POSCAP

Guidelines and Precautions
Mounting specifications
Packing specifications
Selection guide
Surface mount type
Catalog Deletion models
Catalog EOL models

OS-CON

Guidelines and Precautions
Mounting specifications
Packing specifications
Selection guide
Surface mount type
Radial lead type
Catalog EOL models

Hybrid

Guidelines and Precautions
Mounting specifications
Packing specifications
Selection guide
Surface mount type
Radial lead type

Applications

Main market

Laptop computer



Server



Communications infrastructure



Industrial equipment

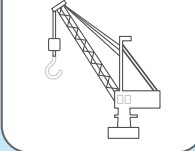

Audio / Visual

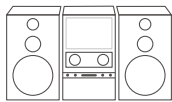

Smart phone
Tablet



Drone

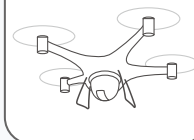

Guidelines and Precautions

SP-Cap

Guidelines and Precautions	
Mounting specifications	
Packing specifications	
Line-up	Selection guide
Series system diagram	
Products list	
CS/CT/CX	
SX	
GX/GX-L	
LX	Surface mount type
SR/LR/SS/LS/ST/LT	
GY	
CY/SY	
JX	
HX	
Catalog EOL models	

POSCAP

Guidelines and Precautions	
Mounting specifications	
Packing specifications	
Selection guide	

Selection guide

Surface mount type

Catalog Deletion models

Catalog EOL models

OS-CON

Guidelines and Precautions	
Mounting specifications	
Packing specifications	
Selection guide	

Selection guide

Surface mount type

Radial lead type

Catalog EOL models

Hybrid

Guidelines and Precautions	
Mounting specifications	
Packing specifications	
Selection guide	

Selection guide

Surface mount type

Radial lead type



Application Guidelines

1. Circuit design

1-1 Prohibited circuits for use

Do not use **SP-Cap** with the following circuit.

- (1) Time constant circuits
- (2) Coupling circuits
- (3) 2 or more **SP-Cap's** connected serially
- (4) Circuits which are greatly affected by leakage current
- (5) High-impedance voltage retention circuits

1-2 Voltage & polarity

Application of over-voltage and reverse voltage described below can cause to increase in leakage current and short circuits. Applied voltage, refers to voltage value including peak value of transitional instantaneous voltage and peak value of ripple voltage, not just steady line voltage.

Design your circuit so that peak voltage does not exceed stipulated voltage.

[Over-Voltage]

Do not apply over-voltage in excess of rated voltage. Do not apply voltage, which exceeds full rated voltage when **SP-Cap** receives impulse voltage, instantaneous high voltage, high pulse voltage etc.

[Reverse-Voltage]

Do not apply reverse-voltage

1-3 Ripple current

Use **SP-Cap** within stipulated permitted ripple current.

When excessive ripple current is applied to **SP-Cap**, it causes increase in leakage current and short circuits due to self-heating.

Even when using **SP-Cap** under permissible ripple current, reverse voltage may occur if DC bias voltage is low.

1-4 Leakage current

There is a risk of leakage current increase even if the following use environments are within the stipulated range.

However, even if leakage current increase **SP-Cap** self-repairing function will reduce leakage current in most cases when a voltage is applied.

- (1) After re-flow
- (2) Shelf conditions such as high temperature with no load, high temperature high humidity with no load and sudden temperature changes.

1-5 Temperature

(1) Use at or under the rated (guaranteed) temperature.

Operation at temperatures exceeding specifications causes large changes in the **SP-Cap** electrical properties, and deterioration than can potentially lead to failure.

When calculating the operating temperature of the **SP-Cap**, be sure to include not only the ambient temperature and internal temperature of the unit, but also radiation from heat generating elements inside the unit (power transistors, resistors, etc.), possibly be applied unexpected temperature through via and pattern of PCB board, and self-heating due to ripple current.

(2) Specified ESR is a value at the time of shipping from factory. ESR may change upon use conditions.

1-6 Failure rate

The majority of failure modes are short circuits or increase in leakage current.

The main factors of failure are mechanical stress, heat stress and electric stress due to re-flow and heat from temperature environment.

Even within stipulated limits, it is possible to lower failure rate by reducing use conditions such as temperature and voltage. Please be sure to have ample margin in your design.

[Expected Failure Rate]

- (1) Date based on our reliability tests: 8.2 Fit or less (Based on applied rated voltage at 105 °C)
- (2) Market failure rate: 0.13 Fit or less (Based on c=0, Reliability standard : 60 %)

1-7 Mounting area consideration

Isolate surface of PCB under mounted **SP-Cap**.

2. Mounting

2-1 When mounting

- (1) Check **SP-Cap** ratings (capacitance and voltage) before mounting.
- (2) Check **SP-Cap** polarity before mounting.
- (3) Check land size for **SP-Cap** before mounting.
- (4) When using a mounter, if the pressure for mounting is too high, then current leak may increase, short-circuiting may occur, or **SP-Cap** may break down or come off.

2-2 Soldering

- (1) Reflow soldering
Be performed by one of following methods.
 - (a) Ambient heat conduction reflow (IR / Hot-air) Refer to the page of "Mounting Specifications".
 - (b) Vapor phase reflow (but only allowable for CX, CT, SX, ST, GX, LX, LT and HX series).
Contact Panasonic for details of allowable vapor phase reflow condition.
- (2) Wave soldering and dip soldering
Please remind SP-Cap is NOT compatible.
- (3) Hand soldering
Excessive force stress to **SP-Cap** should be avoided Conditions :
Tip temperature of soldering iron : 350 °C max.
Exposure time : 10 s max.
※Once removed from printed circuit board for any reason, do not use **SP-Cap** again.

2-3 Land size

Refer to the land size of "Mounting specifications" for appropriate design dimensions.
Circuit board design requires examination of the most suitable dimensions taking conditions such as circuit board, parts and reflow into consideration.

2-4 Mechanical stress

Do not apply excessive force to **SP-Cap** this can damage the electrodes and badly affect **SP-Cap** mount ability.
It can also cause increase of leakage current, separation of the lead wire and element, and damage to **SP-Cap** body, all of which can badly affect electrical performance of **SP-Cap**.

2-5 Circuit board cleaning

SP-Cap should be cleaned after soldering in accordance with the following conditions.

Temperature : Less than 60 °C

Time : Within 5 min

Be sure to sufficiently wash and dry (20 min at 100 °C) a board afterward.

[Recommended Cleaning Solvents]

Pine Alpha ST-100S, Clean-thru 750H / 750L / 710M, Aqua Cleaner 210SEP, Sunelec B-12

DK Beclear CW-5790, Techno Cleaner 219, Cold Cleaner P3-375, Telpene Cleaner EC-7R

Technocare FRW-17 / FRW-1 / FRV-1, AXREL 32, IPA (Isopropyl alcohol)

- (1) Consult our factory when performing processes with cleaning solvents other than those listed above or deionized water.
- (2) The use of ozone depleting cleaning agents are not recommended for protecting environment.
- (3) In case of using ultrasonic cleaning, the terminals may be broken. Therefore, please test before using in mass production.

3.Storage

SP-Cap should be stored in the moisture proof bag. Storage conditions before and after opening the moisture proof bag as follows.

(If these conditions are exceeded, a package may absorb moisture and there is a risk of damage to exterior due to heat stress during mounting.)

[Environment of Storage]

Temperature: 5 °C to 30 °C without direct sunlight

Humidity : Less than 70 %

Maximum storage term before opening the moisture proof bag (2 years after manufactured)

Maximum storage condition after opening the moisture proof bag (7 years after opening)

SP-Cap should be all used within the storage term after opening the moisture proof bag.

SP-Cap

Guidelines and Precautions

Mounting specifications

Packing specifications

Selection guide

Line-up

Series system diagram

Products list

CS/CT/CX

SX

GX/GX-L

LX

SR/LR/SS/LS/ST/LT

GY

CY/SY

JX

HX

Catalog EOL models

Surface mount type

Selection guide

Surface mount type

Surface mount type

Surface mount type

Surface mount type

Surface mount type

Surface mount type

Surface mount type

Surface mount type

Surface mount type

Surface mount type

Surface mount type

Surface mount type

Surface mount type

Surface mount type

Surface mount type

Surface mount type

Surface mount type

Surface mount type

Surface mount type

Surface mount type

Surface mount type

Surface mount type

Surface mount type

Surface mount type

Surface mount type

Surface mount type

Surface mount type

Surface mount type

Surface mount type

Surface mount type

Surface mount type

Surface mount type

Surface mount type

Surface mount type

Surface mount type

Surface mount type

Surface mount type

Surface mount type

Surface mount type

Surface mount type

Surface mount type

Surface mount type

Surface mount type

Surface mount type

Surface mount type

Surface mount type

Surface mount type

Surface mount type

Surface mount type

Surface mount type

Surface mount type

Surface mount type

Surface mount type

Surface mount type

Surface mount type

Surface mount type

Surface mount type

Surface mount type

Surface mount type

Surface mount type

Surface mount type

Surface mount type

Surface mount type

Surface mount type

Surface mount type

Surface mount type

Surface mount type

Surface mount type

Guidelines and Precautions

SP-Cap

Guidelines and Precautions

Mounting specifications

Packing specifications

Line-up

Series system diagram

Products list

CS/CT/CX

SX

GX/GX-L

LX

SR/LR/SS/LS/ST/LT

GY

CY/SY

JX

HX

Catalog EOL models

Guidelines and Precautions

Mounting specifications

Packing specifications

Selection guide

Surface mount type

Radial lead type

Catalog Deletion models

Catalog EOL models

OS-CON

Guidelines and Precautions

Mounting specifications

Packing specifications

Selection guide

Surface mount type

Radial lead type

Catalog EOL models

Hybrid

Guidelines and Precautions

Mounting specifications

Packing specifications

Selection guide

Surface mount type

Radial lead type

Catalog EOL models

4. Transportation

Take sufficient care during handling because excessive vibration, or shock can cause reliability of **SP-Cap** to decrease.

5. Emergency procedures

If a **SP-Cap** is overheated, a resin case may emit smoke. If this occurs, immediately switch off the unit's main power supply to stop operation. Keep your face and hands away from **SP-Cap** until temperature is low enough to cause the **SP-Cap** to ignite and burn.

6. Discarding

Since **SP-Cap** are composed of various metals and resins, treat them as industrial waste when arranging for their disposal.

The precautions for the use of functional polymer aluminum electrolytic capacitors follow the "Precautionary guidelines for the use of fixed aluminum electrolytic capacitors for electronic equipment", RCR-2367B issued by EIAJ in March 2002. Please refer to the above guidelines for details.
This document is subject to change without notice.

Intellectual property right

We, Panasonic Group are providing products and service that customers can use without anxiety, and are working positively on protection of our products under intellectual property rights.
Representative patents relating to **SP-Cap** are as follows:

US Patent No. 7136276, No. 7787234

Mounting specifications/Packing specifications

Recommendable reflow soldering

Recommendable reflow soldering

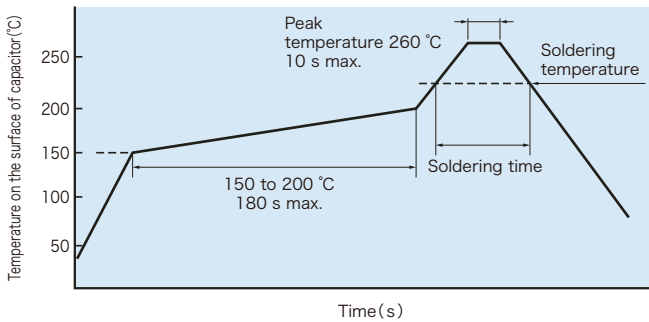

Reflow cycle : 3 max.

Soldering temperature and Soldering time

Temperature	Time
≥ 255 °C	30 s max.
≥ 230 °C	130 s max.
≥ 217 °C	150 s max.

SP-Cap recommended profile condition of the IPC/J-STD-020D standard

Land pattern

Typical land pattern: 2-Terminals

For standard terminal (C*, S*, G*, JX, HX Series)

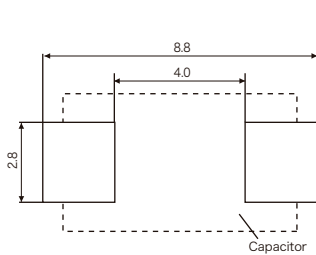

(unit: mm)

Typical land pattern: 3-Terminals

For Low ESL terminal (L*, GX-L Series)

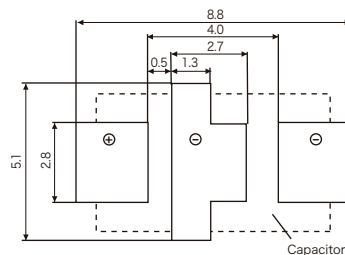

For Low ESL terminal (L*, GX-L Series)

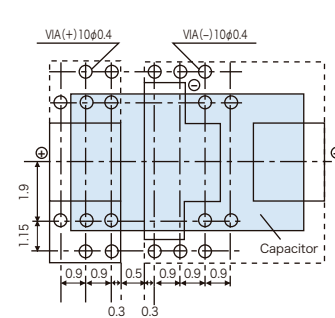

Packaging specifications

Reel dimensions

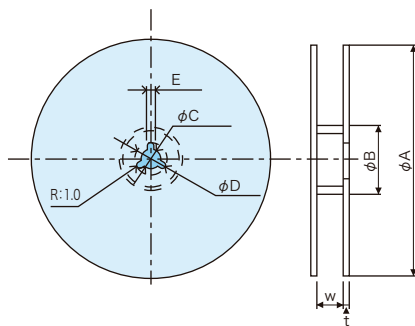

(unit: mm)

Reel	φA	φB	φC	φD	E	W	t
φ330	330	80	13±0.5	21±0.8	2±0.5	14	3

Packaging box dimensions (mm)

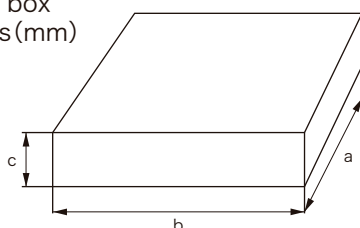

Embossed taping

12 mm tape

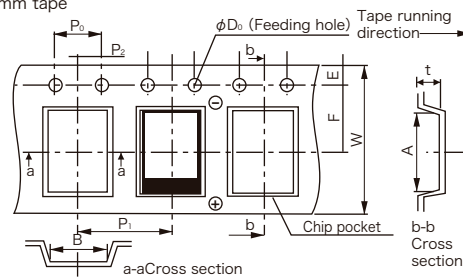

(unit: mm)

A	B	W	F	E	P ₁
7.6±0.2	4.5±0.2	12.0±0.3	5.5±0.1	1.75±0.1	8.0±0.1

P ₂	P ₀	φD ₀	t (Series)		
			*R/*S	*T/*X	*Y
2.0±0.1	4.0±0.1	1.5 ^{+0.1}	1.5±0.2	2.4±0.2	3.5±0.2

(unit: mm)

Reel	a	b	c
φ330	400 max.	400 max.	135 max.

SP-Cap

Guidelines and Precautions

Mounting specifications

Packing specifications

Line-up

Series system diagram

Products list

CS/CT/CX

SX

GX/GX-L

LX

SR/LR/SS/LS/ST/LT

GY

CY/SY

JX

HX

Catalog EOL models

POSCAP

Guidelines and Precautions

Mounting specifications

Packing specifications

Selection guide

Surface mount type

Catalog Deletion models

Catalog EOL models

OS-CON

Guidelines and Precautions

Mounting specifications

Packing specifications

Selection guide

Surface mount type

Radial lead type

Catalog EOL models

Hybrid

Guidelines and Precautions

Mounting specifications

Packing specifications

Selection guide

Surface mount type

Radial lead type

Line-up

SP-Cap

Guidelines and Precautions
Mounting specifications
Packing specifications

Line-up
Series system diagram
Products list

CS/CT/CX
SX
GX/GX-L
LX
SR/LR/SS/LS/ST/LT
GY
CY/SY
JX
HX

Selection guide

Surface mount type

Catalog EOL models

POSCAP

Guidelines and Precautions
Mounting specifications
Packing specifications

Selection guide

Surface mount type

Catalog Deletion models
Catalog EOL models

OS-CON

Guidelines and Precautions
Mounting specifications
Packing specifications

Selection guide

Surface mount type

Radial lead type

Catalog EOL models

Hybrid

Guidelines and Precautions
Mounting specifications
Packing specifications

Selection guide

Surface mount type

Radial lead type

Series	Page	Part No.	Features	Low profile	Low ESR	Low ESL	High voltage	High Temperature	Category temperature range (°C)	Rated voltage (V)	ESR (mΩ)	Capacitance (μF)	Size (mm)
													L×W 7.3×4.3
													H
CX	21 to 22	EEFCX----	Standard				●		-55 to 105	2 to 35	12 to 40	15 to 560	1.9
CT	21 to 22	EEFCT----		●			●		-55 to 105	4 to 35	15 to 40	15 to 180	1.4
CS	21 to 22	EEFCS----		●			●		-55 to 105	4 to 35	15 to 40	10 to 120	1.1
SX	23 to 24	EEFSX----	Low ESR		●				-55 to 105	2 to 6.3	4.5 to 9	82 to 560	1.9
GX	25	EEFGX----	Super low ESR/High ripple current		●	●			-55 to 105	2, 2.5	3	330 to 560	1.9
LX	26	EEFLX----	Low ESR/Low ESL		●	●			-55 to 105	2, 2.5	4.5 to 6	330 to 560	1.9
ST	27 to 28	EEFST----	Low profile/Low ESR	●	●				-55 to 105	2, 2.5	6	270 to 330	1.4
LT	27 to 28	EEFLT----	Low profile/Low ESR/Low ESL	●	●	●			-55 to 105	2, 2.5	6	270 to 330	1.4
SS	27 to 28	EEFSS----	Low profile/Low ESR	●	●				-55 to 105	2, 2.5	6	180 to 220	1.1
LS	27 to 28	EEFLS----	Low profile/Low ESR/Low ESL	●	●	●			-55 to 105	2, 2.5	6	180 to 220	1.1
SR	27 to 28	EEFSR----	Low profile(1.0 mm max.)/Low ESR	●	●				-55 to 105	2 to 6.3	4.5 to 9	68 to 220	1.0 max.
LR	27 to 28	EEFLR----	Low profile(1.0 mm max.)/Low ESL	●	●	●			-55 to 105	2 to 6.3	4.5 to 9	68 to 220	1.0 max.
GY	29	EEFGY---	Super low ESR/ High ripple current / Height 3.0 mm max.		●				-55 to 105	2 to 2.5	3	680 to 820	2.8
CY	30	ECGCY---	Guaranteed at 85°C / Height 3.0 mm max.		●				-55 to 85	4, 6.3	15	330 to 470	2.8
SY	30	ECGSY----	Guaranteed at 85°C / Height 3.0 mm max.		●				-55 to 85	4, 6.3	9	330 to 470	2.8
JX	31 to 32	EEFJX----	Guaranteed at 125 °C		●		●		-55 to 125	2, 2.5	9	220 to 470	1.9
HX	33 to 34	EEFHX----	Guaranteed at 125 °C		●		●	●	-55 to 125	2 to 2.5	4.5 to 40	15 to 470	1.9

Series system diagram

2 terminals

3 terminals

Standard / High Voltage

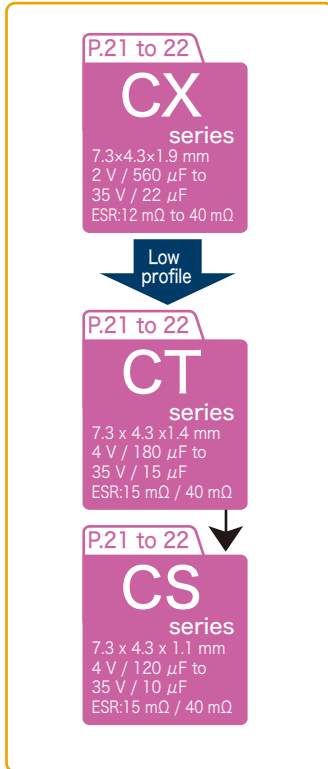

Guaranteed at 85°C



Guaranteed at 125 °C

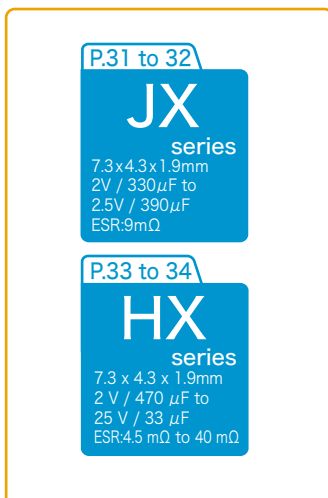

Low ESR

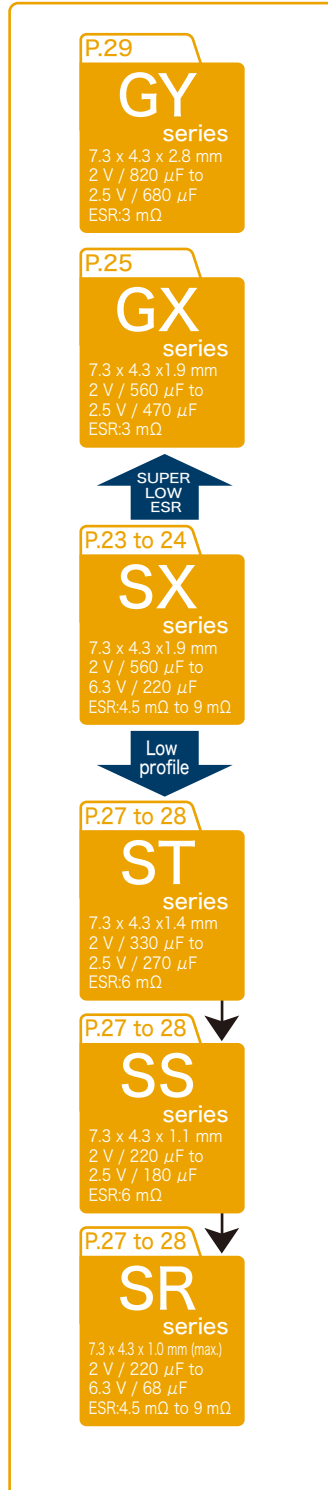

Low ESR / Low ESL[※]

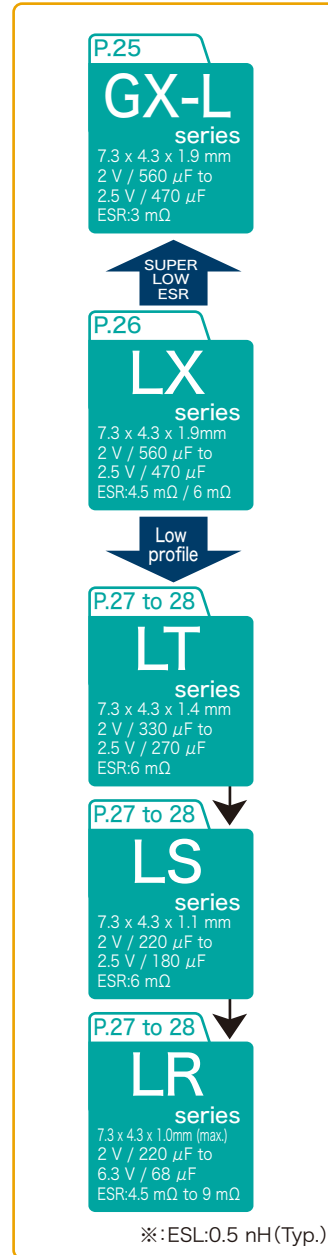

SP-Cap

Guidelines and Precautions
Mounting specifications
Packing specifications
Line-up
Series system diagram
Products list
CS/CT/CX
SX
GX/GX-L
LX
SR/LR/SS/LS/ST/LT
GY
CY/SY
JX
HX
Catalog EOL models

POSCAP

Guidelines and Precautions
Mounting specifications
Packing specifications
Selection guide

Surface mount type

Catalog Deletion models
Catalog EOL models

OS-CON

Guidelines and Precautions
Mounting specifications
Packing specifications
Selection guide

Surface mount type

Radial lead type

Catalog EOL models

Hybrid

Guidelines and Precautions
Mounting specifications
Packing specifications
Selection guide

Surface mount type

Radial lead type

Products list

SP-Cap

- Guidelines and Precautions
- Mounting specifications
- Packing specifications
- Line-up
- Series system diagram
- Selection guide
- Products list**
- CS/CT/CX
- SX
- GX/GX-L
- LX
- SR/LR/SS/LS/ST/LT
- GY
- CY/SY
- JX
- HX
- Surface mount type
- Catalog EOL models

Series·ESR Matrix list

Series (ESR mΩ)

μF	10	15	22	33	47	56	68	82	100	120
2.0										
2.5										
4.0								SX(9)	SX(9)	CS(15) SR(9) LR(9)
6.3							CS(15) SR(9) LR(9)		CT(15) CX(15)	CX(15) SX(7)
10					CS(40) CX(40) HX(40)		CT(40) CX(40) HX(40)		CX(40) HX(40)	
16		CS(40) CX(40) HX(40)	CS(40) CX(40) HX(40)	CS(40) CX(40) HX(40)	CT(40) CX(40) HX(40)		CX(40) HX(40)			
20	CS(40)	CS(40)	CS(40) CX(40) HX(40)	CT(40) CX(40) HX(40)	CT(40) CX(40) HX(40)	CX(40) HX(40)				
25	CS(40)	CS(40) CX(40) HX(40)	CT(40) CX(40) HX(40)	CX(40) HX(40)					Not Recommended for New Design	
35	CS(40)	CT(40) CX(40)	CX(40)							

- POSCAP**
- Guidelines and Precautions
- Mounting specifications
- Packing specifications
- Selection guide
- Surface mount type
- Catalog Deletion models
- Catalog EOL models

- OS-CON**
- Guidelines and Precautions
- Mounting specifications
- Packing specifications
- Selection guide
- Surface mount type
- Radial lead type
- Catalog EOL models

- Hybrid**
- Guidelines and Precautions
- Mounting specifications
- Packing specifications
- Selection guide
- Surface mount type
- Radial lead type

SP-Cap

- Guidelines and Precautions
- Mounting specifications
- Packing specifications
- Line-up
- Series system diagram
- Products list
- CS/CT/CX
- SX
- GX/GX-L
- LX
- SR/LR/SS/LS/ST/LT
- GY
- CY/SY
- JX
- HX
- Catalog EOL models

POSCAP

- Guidelines and Precautions
- Mounting specifications
- Packing specifications
- Selection guide

Surface mount type

Catalog Deletion models
Catalog EOL models

OS-CON

- Guidelines and Precautions
- Mounting specifications
- Packing specifications
- Selection guide

Surface mount type

Radial lead type

Catalog EOL models

Hybrid

- Guidelines and Precautions
- Mounting specifications
- Packing specifications
- Selection guide

Surface mount type

Radial lead type

μF V	150	180	220	270	330	390	470	560	680	820
2.0		SX(9)	CX(15)	CX(12)	CX(15/12)	CX(15)	CX(15)	CX(15)		GY(3)
			SX(9)	SX(9/6/4.5)	SX(9/6/4.5)	SX(9/6/4.5)	SX(9/6/4.5)	SX(4.5)		
			SR(6/4.5)		GX(3)		GX(3)	GX(3)		
			LR(6/4.5)		LX(6/4.5)		GX-L(3)	GX-L(3)		
			SS(6)		ST(6)		LX(6/4.5)	LX(6/4.5)		
			LS(6)		LT(6)		JX (9)			
					JX (9)		HX(15/9/6/4.5)			
2.5	SX(9)	SX(9)	CX(15)	SX(7)	CX(15)	CX(15)	CX(15)			GY(3)
		SR(6/4.5)	SX(9/7)	ST(6)	SX(9/6/4.5)	SX(9/6/4.5)	SX(9/6/4.5)			
		LR(6/4.5)	JX (9)	LT(6)	GX(3)	JX (9)	GX(3)			
		SS(6)			LX(6/4.5)		GX-L(3)			
		LS(6)			JX (9)		LX(6/4.5)			
					HX(15/9/6/4.5)					
4.0	CX(15)	CT(15)	CX(15/12)	CX(15)	CX(15)		CY(15)			
	SX(9/7)	CX(15/12)	SX(9)	SX(9)	SX(9/6/4.5)		SY(9)			
		SX(9)								
6.3	CX(15/12)	CX(15)	CX(15)		CY(15)					
	SX(9)	SX(9)	SX(9)		SY(9)					



High ripple current(5600 mA rms max.)

Low profile(Height 1.1 mm)

RoHS compliance, Halogen free

SP-Cap

- Guidelines and Precautions
- Mounting specifications
- Packing specifications
- Line-up
- Series system diagram
- Products list
- CS/CT/CX
- SX
- GX/GX-L
- LX
- SR/LR/SS/LS/ST/LT
- GY
- CY/SY
- JX
- HX
- Catalog EOL models

POSCAP

- Guidelines and Precautions
- Mounting specifications
- Packing specifications
- Selection guide

Surface mount type

Specifications

Items	Specifications			
	CS	CT	CX	
Category temperature range	-55 °C to 105 °C			
Rated voltage range	4 V to 35 V		2 V to 35 V	
Rated capacitance range	10 µF to 120 µF	15 µF to 180 µF	15 µF to 560 µF	
Capacitance tolerance	±20 %(120 Hz/20 °C)			
Leakage current	I ≤ 0.1 CV(µA)[2 V to 6.3 V, 2 minutes], I ≤ 0.3 CV(µA)[10 V to 35 V, 2 minutes]			
Dissipation factor(tanδ)	≤ 0.06(120 Hz/20 °C)			
Surge voltage(V)	Rated voltage × 1.25[2 V to 16 V], × 1.15[20 V to 35 V] (15 °C to 35 °C)			
Endurance	+105°C, 2000 h, rated voltage applied			
	Capacitance change	Within ±20% of the initial value		
	tanδ	≤ 2 times of the initial limit		
	DC leakage current	≤ 3 times of the initial limit[2 V to 6.3 V], ≤ Within the initial limit[10 V to 35 V]		
Damp heat(Steady state)	+60°C, 90% RH, 500 h, No-applied voltage			
	Capacitance change of initial measurd value	2 V to 2.5 V +70 %, -20 %	4 V, 10 V to 35 V +60 %, -20 %	6.3 V +50 %, -20 %
	tan δ	≤ 2 times of the initial limit		
	DC leakage current	Within the initial limit[2 V to 6.3 V], ≤ 3 times of the initial limit[10 V to 35 V]		

Marking and Dimensions (not to scale)

R. capacitance (µF) Polarity bar(Positive)

Lot.No. R. voltage code

Rated voltage(V)	2	2.5	4	6.3	10
Code	d	e	g	j	A

Rated voltage(V)	16	20	25	35
Code	C	D	E	V

(Unit : mm)

Series	L ±0.2	W1 ±0.2	W2 ±0.1	H ±0.1	P ±0.3
CS	7.3	4.3	2.4	1.1	1.3
CT	7.3	4.3	2.4	1.4	1.3
CX	7.3	4.3	2.4	1.9	1.3

Characteristics list (2 to 6.3 V)

Series	Rated voltage (V)	Capacitance (µF)	Case size (mm)			Specifications		Part number	Min. Packaging Q'ty ※3 (pcs)
			L	W	H	Ripple current ※1 (mA rms)	ESR ※2 (mΩ max.)		
CS	4	120	7.3	4.3	1.1	5100	15	EEFCS0G121R	3500
	6.3	68	7.3	4.3	1.1	5100	15	EEFCS0J680R	3500
CT	4	180	7.3	4.3	1.4	5100	15	EEFCT0G181R	3500
	6.3	100	7.3	4.3	1.4	5100	15	EEFCT0J101R	3500
CX	2	220	7.3	4.3	1.9	5100	15	EEFCX0D221R	3500
		270	7.3	4.3	1.9	5600	12	EEFCX0D271XR	3500
		330	7.3	4.3	1.9	5100	15	EEFCX0D331R	3500
			7.3	4.3	1.9	5600	12	EEFCX0D331XR	3500
		390	7.3	4.3	1.9	5100	15	EEFCX0D391R	3500
		470	7.3	4.3	1.9	5100	15	EEFCX0D471R	3500
		560	7.3	4.3	1.9	5100	15	EEFCX0D561R	3500
		2.5	220	7.3	4.3	1.9	5100	15	EEFCX0E221R
	330		7.3	4.3	1.9	5100	15	EEFCX0E331R	3500
	390		7.3	4.3	1.9	5100	15	EEFCX0E391R	3500
	470		7.3	4.3	1.9	5100	15	EEFCX0E471R	3500
	4	150	7.3	4.3	1.9	5100	15	EEFCX0G151R	3500
		180	7.3	4.3	1.9	5100	15	EEFCX0G181R	3500
			7.3	4.3	1.9	5600	12	EEFCX0G181XR	3500
		220	7.3	4.3	1.9	5100	15	EEFCX0G221R	3500
			7.3	4.3	1.9	5600	12	EEFCX0G221XR	3500
		270	7.3	4.3	1.9	5100	15	EEFCX0G271R	3500
		330	7.3	4.3	1.9	5100	15	EEFCX0G331R	3500
		6.3	100	7.3	4.3	1.9	5100	15	EEFCX0J101R
	120		7.3	4.3	1.9	5100	15	EEFCX0J121R	3500
150	7.3		4.3	1.9	5100	15	EEFCX0J151R	3500	
	7.3		4.3	1.9	5600	12	EEFCX0J151XR	3500	
180	7.3		4.3	1.9	5100	15	EEFCX0J181R	3500	
220	7.3		4.3	1.9	5100	15	EEFCX0J221R	3500	

Characteristics list (10 to 35 V) Not Recommended for New Design

Series	Rated voltage (V)	Capacitance (μF)	Case size (mm)			Specifications		Part number	Min. Packaging Q'ty ※3 (pcs)
			L	W	H	Ripple current ※1 (mA rms)	ESR ※2 (mΩ max.)		
CS	10	47	7.3	4.3	1.1	3200	40	EEFCS1A470R	3500
		15	7.3	4.3	1.1	3200	40	EEFCS1C150R	3500
		22	7.3	4.3	1.1	3200	40	EEFCS1C220R	3500
	16	33	7.3	4.3	1.1	3200	40	EEFCS1C330R	3500
		10	7.3	4.3	1.1	3200	40	EEFCS1D100R	3500
		15	7.3	4.3	1.1	3200	40	EEFCS1D150R	3500
	20	22	7.3	4.3	1.1	3200	40	EEFCS1D220R	3500
		10	7.3	4.3	1.1	3200	40	EEFCS1E100R	3500
		15	7.3	4.3	1.1	3200	40	EEFCS1E150R	3500
	25	35	7.3	4.3	1.1	3200	40	EEFCS1V100R	3500
		10	7.3	4.3	1.4	3200	40	EEFCT1A680R	3500
	CT	16	47	7.3	4.3	1.4	3200	40	EEFCT1C470R
33			7.3	4.3	1.4	3200	40	EEFCT1D330R	3500
20		47	7.3	4.3	1.4	3200	40	EEFCT1D470R	3500
		22	7.3	4.3	1.4	3200	40	EEFCT1E220R	3500
35		7.3	4.3	1.4	3200	40	EEFCT1V150R	3500	
CX	10	47	7.3	4.3	1.9	3200	40	EEFCX1A470R	3500
		68	7.3	4.3	1.9	3200	40	EEFCX1A680R	3500
		100	7.3	4.3	1.9	3200	40	EEFCX1A101R	3500
	16	15	7.3	4.3	1.9	3200	40	EEFCX1C150R	3500
		22	7.3	4.3	1.9	3200	40	EEFCX1C220R	3500
		33	7.3	4.3	1.9	3200	40	EEFCX1C330R	3500
		47	7.3	4.3	1.9	3200	40	EEFCX1C470R	3500
		68	7.3	4.3	1.9	3200	40	EEFCX1C680R	3500
	20	22	7.3	4.3	1.9	3200	40	EEFCX1D220R	3500
		33	7.3	4.3	1.9	3200	40	EEFCX1D330R	3500
		47	7.3	4.3	1.9	3200	40	EEFCX1D470R	3500
		56	7.3	4.3	1.9	3200	40	EEFCX1D560R	3500
	25	15	7.3	4.3	1.9	3200	40	EEFCX1E150R	3500
		22	7.3	4.3	1.9	3200	40	EEFCX1E220R	3500
		33	7.3	4.3	1.9	3200	40	EEFCX1E330R	3500
	35	15	7.3	4.3	1.9	3200	40	EEFCX1V150R	3500
		22	7.3	4.3	1.9	3200	40	EEFCX1V220R	3500

※1: Ripple current (100 kHz/ +45 °C)

※2: ESR (100 kHz/+20 °C)

※3: Please contact us when 500 pcs packing is necessary

◆Please refer to the P16 in this catalog for "Reflow conditions" and "Taping specifications".

Temperature coefficient of Ripple current

Temperature		T ≤ 45 °C	45 °C < T ≤ 85 °C	85 °C < T ≤ 105 °C
2 V to 6.3 V	Coefficient	1.0	0.7	0.25
10 V to 35 V		1.0	0.8	0.5

SP-Cap

Guidelines and Precautions

Mounting specifications

Packing specifications

Line-up

Series system diagram

Products list

CS/CT/CX

SX

GX/GX-L

LX

SR/LR/SS/LS/ST/LT

GY

CY/SY

JX

HX

Catalog EOL models

POSCAP

Guidelines and Precautions

Mounting specifications

Packing specifications

Selection guide

Surface mount type

Surface mount type

Surface mount type

Surface mount type

Surface mount type

Surface mount type

Surface mount type

Surface mount type

Surface mount type

Surface mount type

Surface mount type

Surface mount type

Surface mount type

Surface mount type

Surface mount type

Surface mount type

Surface mount type

Surface mount type

Surface mount type

Surface mount type

Surface mount type

Surface mount type

Surface mount type

Surface mount type

Surface mount type

Surface mount type

Surface mount type

Surface mount type

Surface mount type

Surface mount type

Surface mount type

Surface mount type

Surface mount type

Surface mount type

Surface mount type

Surface mount type

Surface mount type

Surface mount type

Surface mount type

Surface mount type

Surface mount type

Surface mount type

Surface mount type

Surface mount type

Surface mount type

Surface mount type

Surface mount type

Surface mount type

Surface mount type

Surface mount type

Surface mount type

Surface mount type

Surface mount type

Surface mount type

Surface mount type

Surface mount type

Surface mount type

Surface mount type

Surface mount type

Surface mount type

Surface mount type

Surface mount type

Surface mount type

Surface mount type

Surface mount type

Surface mount type

Surface mount type

Surface mount type

Surface mount type

Surface mount type

Surface mount type

Surface mount type

Surface mount type

Surface mount type

Surface mount type

Surface mount type



- Large capacitance (560 μ F max.)
- High ripple current (8500 mA rms max.)
- Low ESR (4.5 m Ω to 9 m Ω max.)
- RoHS compliance, Halogen free

SP-Cap

- Guidelines and Precautions
- Mounting specifications
- Packing specifications
- Line-up
- Series system diagram
- Products list
- CS/CT/CX
- SX**
- GX/GX-L
- LX
- SR/LR/SS/LS/ST/LT
- GY
- CY/SY
- JX
- HX
- Catalog EOL models

POSCAP

- Guidelines and Precautions
- Mounting specifications
- Packing specifications
- Selection guide

Surface mount type

- Catalog Deletion models
- Catalog EOL models

OS-CON

- Guidelines and Precautions
- Mounting specifications
- Packing specifications
- Selection guide

Surface mount type

Radial lead type

Catalog EOL models

Hybrid

- Guidelines and Precautions
- Mounting specifications
- Packing specifications
- Selection guide

Surface mount type

Radial lead type

Specifications

Items	Specifications			
Series	SX			
Category temperature range	-55 °C to 105 °C			
Rated voltage range	2 V to 6.3 V			
Rated capacitance range	82 μ F to 560 μ F			
Capacitance tolerance	\pm 20 % (120 Hz/20 °C)			
Leakage current	$I \leq 0.1 CV(\mu A)$ [2 minutes]			
Dissipation factor (tan δ)	≤ 0.06 (120 Hz/20 °C)			
Surge voltage (V)	Rated voltage \times 1.25 (15 °C to 35 °C)			
Endurance	+105 °C, 2000 h, rated voltage applied			
	Capacitance change	Within \pm 20 % of the initial value		
	tan δ	≤ 2 times of the initial limit		
	DC leakage current	≤ 3 times of the initial limit		
Damp heat (Steady state)	+60 °C, 90 % RH, 500 h, No-applied voltage			
	Capacitance change of initial measur value	2 V to 2.5 V	4 V	6.3 V
		+70 %, -20 %	+60 %, -20 %	+50 %, -20 %
	tan δ	≤ 2 times of the initial limit		
DC leakage current	Within the initial limit			

Marking and Dimensions

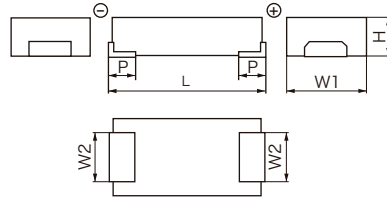
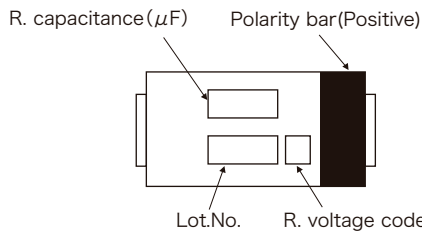

Rated voltage (V)	2	2.5	4	6.3
Code	d	e	g	j

(Unit : mm)

Series	L \pm 0.2	W1 \pm 0.2	W2 \pm 0.1	H \pm 0.1	P \pm 0.3
SX	7.3	4.3	2.4	1.9	1.3

Characteristics list

Series	Rated voltage (V)	Capacitance (μF)	Case size (mm)			Specifications		Part number	Min. Packaging Q'ty ※3 (pcs)
			L	W	H	Ripple current ※1 (mA rms)	ESR ※2 (mΩ max.)		
SX	2	180	7.3	4.3	1.9	6300	9	EEFSX0D181ER	3500
		220	7.3	4.3	1.9	6300	9	EEFSX0D221ER	3500
		270	7.3	4.3	1.9	6300	9	EEFSX0D271ER	3500
			7.3	4.3	1.9	7500	6	EEFSX0D271XE	3500
			7.3	4.3	1.9	8500	4.5	EEFSX0D271E4	3500
		330	7.3	4.3	1.9	6300	9	EEFSX0D331ER	3500
			7.3	4.3	1.9	7500	6	EEFSX0D331XE	3500
			7.3	4.3	1.9	8500	4.5	EEFSX0D331E4	3500
		390	7.3	4.3	1.9	6300	9	EEFSX0D391ER	3500
			7.3	4.3	1.9	7500	6	EEFSX0D391XE	3500
			7.3	4.3	1.9	8500	4.5	EEFSX0D391E4	3500
		470	7.3	4.3	1.9	6300	9	EEFSX0D471ER	3500
	7.3		4.3	1.9	7500	6	EEFSX0D471XE	3500	
	7.3		4.3	1.9	8500	4.5	EEFSX0D471E4	3500	
	560	7.3	4.3	1.9	8500	4.5	EEFSX0D561E4	3500	
	2.5	150	7.3	4.3	1.9	6300	9	EEFSX0E151ER	3500
		180	7.3	4.3	1.9	6300	9	EEFSX0E181ER	3500
		220	7.3	4.3	1.9	6300	9	EEFSX0E221ER	3500
			7.3	4.3	1.9	7000	7	EEFSX0E221E7	3500
		270	7.3	4.3	1.9	7000	7	EEFSX0E271E7	3500
			7.3	4.3	1.9	6300	9	EEFSX0E331ER	3500
			7.3	4.3	1.9	7500	6	EEFSX0E331XE	3500
		330	7.3	4.3	1.9	8500	4.5	EEFSX0E331E4	3500
			7.3	4.3	1.9	6300	9	EEFSX0E391ER	3500
			7.3	4.3	1.9	7500	6	EEFSX0E391XE	3500
		390	7.3	4.3	1.9	8500	4.5	EEFSX0E391E4	3500
			7.3	4.3	1.9	6300	9	EEFSX0E471ER	3500
		470	7.3	4.3	1.9	7500	6	EEFSX0E471XE	3500
			7.3	4.3	1.9	8500	4.5	EEFSX0E471E4	3500
			7.3	4.3	1.9	6300	9	EEFSX0E471ER	3500
4		82	7.3	4.3	1.9	6300	9	EEFSX0G820ER	3500
		100	7.3	4.3	1.9	6300	9	EEFSX0G101ER	3500
			7.3	4.3	1.9	6300	9	EEFSX0G151ER	3500
	150	7.3	4.3	1.9	7000	7	EEFSX0G151E7	3500	
		7.3	4.3	1.9	6300	9	EEFSX0G181ER	3500	
	220	7.3	4.3	1.9	6300	9	EEFSX0G221ER	3500	
	270	7.3	4.3	1.9	6300	9	EEFSX0G271ER	3500	
		7.3	4.3	1.9	6300	9	EEFSX0G331ER	3500	
	330	7.3	4.3	1.9	7500	6	EEFSX0G331XE	3500	
7.3		4.3	1.9	6300	9	EEFSX0J121E7	3500		
6.3	120	7.3	4.3	1.9	7000	7	EEFSX0J121E7	3500	
	150	7.3	4.3	1.9	6300	9	EEFSX0J151ER	3500	
	180	7.3	4.3	1.9	6300	9	EEFSX0J181ER	3500	
	220	7.3	4.3	1.9	6300	9	EEFSX0J221ER	3500	

※1:Ripple current (100 kHz/ +45 °C)

※2:ESR (100 kHz/+20 °C)

※3:Please contact us when 500 pcs packing is necessary

◆Please refer to the P16 in this catalog for "Reflow conditions" and "Taping specifications".

Temperature coefficient of Ripple current

Temperature	T ≤ 45 °C	45 °C < T ≤ 85 °C	85 °C < T ≤ 105 °C
Coefficient	1.0	0.7	0.25



Large capacitance(560 µF max.)

Low ESL(3 terminals : 50% less than 2-terminals) [Suffix : L]

High ripple current(10200 mA rms max.)

Super low ESR(3 mΩ max.)

RoHS compliance, Halogen free

SP-Cap

- Guidelines and Precautions
- Mounting specifications
- Packing specifications
- Line-up
- Series system diagram
- Products list
- CS/CT/CX
- SX
- GX/GX-L**
- LX
- SR/LR/SS/LS/ST/LT
- GY
- CY/SY
- JX
- HX
- Surface mount type
- Selection guide
- Catalog EOL models

POSCAP

- Guidelines and Precautions
- Mounting specifications
- Packing specifications
- Selection guide
- Surface mount type

- Catalog Deletion models
- Catalog EOL models

OS-CON

- Guidelines and Precautions
- Mounting specifications
- Packing specifications
- Selection guide

Surface mount type

Radial lead type

Catalog EOL models

Hybrid

- Guidelines and Precautions
- Mounting specifications
- Packing specifications

Selection guide

Surface mount type

Radial lead type

Specifications

Items	Specifications	
Series	GX	
Category temperature range	-55 °C to 105 °C	
Rated voltage range	2 V, 2.5 V	
Rated capacitance range	330 µF to 560 µF	
Capacitance tolerance	±20 %(120 Hz/+20 °C)	
Leakage current	I ≤ 0.1 CV(µA)[2 minutes]	
Dissipation factor(tanδ)	≤ 0.06(120 Hz/+20 °C)	
Surge voltage(V)	Rated voltage ×1.25(15 °C to 35 °C)	
Endurance	+105 °C, 2000 h, rated voltage applied	
	Capacitance change	Within ±20 % of the initial value
	tanδ	≤ 2 times of the initial limit
	DC leakage current	≤ 3 times of the initial limit
Damp heat(Steady state)	+60 °C, 90 % RH, 500 h, No-applied voltage	
	Capacitance change of initial measur value	2 V, 2.5 V +70 %, -20 %
	tan δ	≤ 2 times of the initial limit
	DC leakage current	Within the initial limit

Marking and Dimensions

R. capacitance(µF) Polarity bar(Positive)

Rated voltage(V)	2	2.5
Code	d	e

Lot.No. R. voltage code

2 terminals 3 terminals

(Unit : mm)

Series	L ±0.2	W1 ±0.2	W2 ±0.1	H ±0.1	P ±0.3
GX	7.3	4.3	2.4	1.9	1.3

Series	L ±0.2	W1 ±0.2	W2 ±0.1	H ±0.1	P1 ±0.3	P2 ±0.1	P3 ±0.2	P4 ±0.2
GX-L	7.3	4.3	2.4	1.9	1.3	1.1	0.7	1.4

Characteristics list

Series	Rated voltage (V)	Capacitance (µF)	Case size (mm)			Specifications		The number of terminals		Part number	Min. Packaging Qty ※3 (pcs)
			L	W	H	Ripple current ※1 (mA rms)	ESR ※2 (mΩ max.)	2	3		
GX	2	330	7.3	4.3	1.9	10200	3	○		EEFGX0D331R	3500
			7.3	4.3	1.9	10200	3	○		EEFGX0D471R	3500
			7.3	4.3	1.9	10200	3		○	EEFGX0D471L	3500
	2.5	560	7.3	4.3	1.9	10200	3	○		EEFGX0D561R	3500
			7.3	4.3	1.9	10200	3		○	EEFGX0D561L	3500
			7.3	4.3	1.9	10200	3	○		EEFGX0E331R	3500
			7.3	4.3	1.9	10200	3	○		EEFGX0E471R	3500
			7.3	4.3	1.9	10200	3		○	EEFGX0E471L	3500

※1:Ripple current (100 kHz/ +45 °C) ※2:ESR (100 kHz/+20 °C) ※3:Please contact us when 500 pcs packing is necessary

◆Please refer to the P16 in this catalog for "Reflow conditions" and "Taping specifications".

Temperature coefficient of Ripple current

Temperature	T ≤ 45 °C	45 °C < T ≤ 85 °C	85 °C < T ≤ 105 °C
Coefficient	1.0	0.7	0.25

Design and specifications are each subject to change without notice. Ask factory for the current technical specifications before purchase and/or use. Should a safety concern arise regarding this product, please be sure to contact us immediately.



- Large capacitance (560 µF max.)
- Low ESL (3 terminals : 50% less than 2-terminals)
- Super low ESR (4.5 mΩ, 6 mΩ max.)
- High ripple current (8500 mA rms max.)
- RoHS compliance, Halogen free

Specifications		
Items	Specifications	
Series	LX	
Category temperature range	-55 °C to 105 °C	
Rated voltage range	2 V, 2.5 V	
Rated capacitance range	330 µF to 560 µF	
Capacitance tolerance	±20 % (120 Hz/+20 °C)	
Leakage current	$I \leq 0.1 CV(\mu A)$ [2 minutes]	
Dissipation factor (tan δ)	≤ 0.06 (120 Hz/+20 °C)	
Surge voltage (V)	Rated voltage $\times 1.25$ (15 °C to 35 °C)	
Endurance	+105 °C, 2000 h, rated voltage applied	
	Capacitance change	Within ±20 % of the initial value
	tan δ	≤ 2 times of the initial limit
	DC leakage current	≤ 3 times of the initial limit
Damp heat (Steady state)	+60 °C, 90 % RH, 500 h, No-applied voltage	
	Capacitance change of initial measured value	2 V, 2.5 V +70 %, -20 %
	tan δ	≤ 2 times of the initial limit
	DC leakage current	Within the initial limit

Marking and Dimensions

(Unit : mm)

Rated voltage (V)	2	2.5
Code	d	e

Series	L ±0.2	W1 ±0.2	W2 ±0.1	H ±0.1	P1 ±0.3	P2 ±0.1	P3 ±0.2	P4 ±0.2
LX	7.3	4.3	2.4	1.9	1.3	1.1	0.7	1.4

Characteristics list

Series	Rated voltage (V)	Capacitance (µF)	Case size (mm)			Specifications		Part number	Min. Packaging Q'ty ※3 (pcs)
			L	W	H	Ripple current ※1 (mA rms)	ESR ※2 (mΩ max.)		
LX	2	330	7.3	4.3	1.9	7500	6	EEFLX0D331R	3500
			7.3	4.3	1.9	8500	4.5	EEFLX0D331R4	3500
		470	7.3	4.3	1.9	7500	6	EEFLX0D471R	3500
			7.3	4.3	1.9	8500	4.5	EEFLX0D471R4	3500
		560	7.3	4.3	1.9	7500	6	EEFLX0D561R	3500
			7.3	4.3	1.9	8500	4.5	EEFLX0D561R4	3500
	2.5	330	7.3	4.3	1.9	7500	6	EEFLX0E331R	3500
			7.3	4.3	1.9	8500	4.5	EEFLX0E331R4	3500
470		7.3	4.3	1.9	7500	6	EEFLX0E471R	3500	
		7.3	4.3	1.9	8500	4.5	EEFLX0E471R4	3500	

※1: Ripple current (100 kHz/ +45 °C) ※2: ESR (100 kHz/+20 °C) ※3: Please contact us when 500 pcs packing is necessary
 ◆Please refer to the P16 in this catalog for "Reflow conditions" and "Taping specifications".

Temperature coefficient of Ripple current

Temperature	T ≤ 45 °C	45 °C < T ≤ 85 °C	85 °C < T ≤ 105 °C
Coefficient	1.0	0.7	0.25

SP-Cap

- Guidelines and Precautions
- Mounting specifications
- Packing specifications
- Line-up
- Series system diagram
- Products list
- CS/CT/CX
- SX
- GX/GX-L
- LX**
- SR/LR/SS/LS/ST/LT
- GY
- CY/SY
- JX
- HX
- Catalog EOL models

POSCAP

- Guidelines and Precautions
- Mounting specifications
- Packing specifications
- Selection guide

Surface mount type

- Catalog Deletion models
- Catalog EOL models

OS-CON

- Guidelines and Precautions
- Mounting specifications
- Packing specifications
- Selection guide

Surface mount type

Radial lead type

- Catalog EOL models

Hybrid

- Guidelines and Precautions
- Mounting specifications
- Packing specifications
- Selection guide

Surface mount type

Radial lead type



Low profile (Height 1.0 mm max.)

Low ESL (3 terminals): 50% less than 2-terminals (LR, LS, LT series)

High ripple current (8500 mA rms max.)

Super low ESR (4.5 mΩ to 9 mΩ)

RoHS compliance, Halogen free

SP-Cap

- Guidelines and Precautions
- Mounting specifications
- Packing specifications
- Line-up
- Series system diagram
- Products list
- CS/CT/CX
- SX
- GX/GX-L
- LX
- SR/LR/SS/LS/ST/LT
- GY
- CY/SY
- JX
- HX
- Catalog EOL models

Specifications

Items	Specifications						
	Series	SR	LR	SS	LS	ST	LT
Category temperature range	-55 °C to 105 °C						
Rated voltage range	2 V to 6.3 V		2 V, 2.5 V				
Rated capacitance range	68 μF to 220 μF		180 μF to 220 μF		270 μF to 330 μF		
Capacitance tolerance	±20 % (120 Hz/+20 °C)						
Leakage current	$I \leq 0.1 CV(\mu A)$ [2 minutes]						
Dissipation factor (tanδ)	≤ 0.06 (120 Hz/+20 °C)						
Surge voltage (V)	Rated voltage × 1.25 (15 °C to 35 °C)						
Endurance	+105 °C, 2000 h, rated voltage applied						
	Capacitance change	Within ±20 % of the initial value					
	tanδ	≤ 2 times of the initial limit					
	DC leakage current	≤ 3 times of the initial limit					
Damp heat (Steady state)	+60 °C, 90 % RH, 500 h, No-applied voltage						
	Capacitance change of initial measur value	2 V, 2.5 V		4 V		6.3 V	
		+70 %, -20 %		+60 %, -20 %		+50 %, -20 %	
	tan δ	≤ 2 times of the initial limit					
DC leakage current	Within the initial limit						

POSCAP

- Guidelines and Precautions
- Mounting specifications
- Packing specifications
- Selection guide

Surface mount type

- Catalog Deletion models
- Catalog EOL models

OS-CON

- Guidelines and Precautions
- Mounting specifications
- Packing specifications
- Selection guide

Surface mount type

Marking and Dimensions

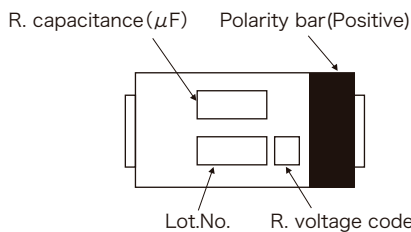

2 terminals

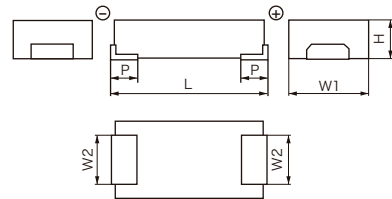

(Unit : mm)

Series	L ±0.2	W1 ±0.2	W2 ±0.1	H ±0.1	P ±0.3
SR	7.3	4.3	2.4	1.0 ^{※1}	1.3
SS	7.3	4.3	2.4	1.1	1.3
ST	7.3	4.3	2.4	1.4	1.3

※1 Maximum

3 terminals

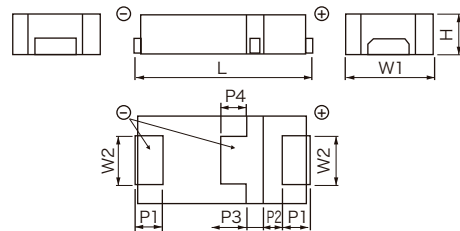

(Unit : mm)

Series	L ±0.2	W1 ±0.2	W2 ±0.1	H ±0.1	P1 ±0.3	P2 ±0.1	P3 ±0.2	P4 ±0.2
LR	7.3	4.3	2.4	1.0 ^{※1}	1.3	1.1	0.7	1.4
LS	7.3	4.3	2.4	1.1	1.3	1.1	0.7	1.4
LT	7.3	4.3	2.4	1.4	1.3	1.1	0.7	1.4

※1 Maximum

Rated voltage (V)	2	2.5	4	6.3
Code	d	e	g	j

Radial lead type

Catalog EOL models

Hybrid

- Guidelines and Precautions
- Mounting specifications
- Packing specifications
- Selection guide

Surface mount type

Radial lead type

Characteristics list

Series	Rated voltage (V)	Capacitance (μF)	Case size (mm)			Specifications		The number of terminals		Part number	Min. Packaging Qty ※3 (pcs)
			L	W	H	Ripple current ※1 (mA rms)	ESR ※2 (mΩ max.)	2	3		
SR	2	220	7.3	4.3	1.0 max.	7500	6	○		EEFSR0D221R	3500
			7.3	4.3	1.0 max.	8500	4.5	○		EEFSR0D221R4	3500
	2.5	180	7.3	4.3	1.0 max.	7500	6	○		EEFSR0E181R	3500
			7.3	4.3	1.0 max.	8500	4.5	○		EEFSR0E181R4	3500
	4	120	7.3	4.3	1.0 max.	6300	9	○		EEFSR0G121R	3500
	6.3	68	7.3	4.3	1.0 max.	6300	9	○		EEFSR0J680R	3500
LR	2	220	7.3	4.3	1.0 max.	7500	6		○	EEFLR0D221R	3500
			7.3	4.3	1.0 max.	8500	4.5		○	EEFLR0D221R4	3500
	2.5	180	7.3	4.3	1.0 max.	7500	6		○	EEFLR0E181R	3500
			7.3	4.3	1.0 max.	8500	4.5		○	EEFLR0E181R4	3500
	4	120	7.3	4.3	1.0 max.	6300	9		○	EEFLR0G121R	3500
	6.3	68	7.3	4.3	1.0 max.	6300	9		○	EEFLR0J680R	3500
SS	2	220	7.3	4.3	1.1	7500	6	○		EEFSS0D221R	3500
	2.5	180	7.3	4.3	1.1	7500	6	○		EEFSS0E181R	3500
LS	2	220	7.3	4.3	1.1	7500	6		○	EEFLS0D221R	3500
	2.5	180	7.3	4.3	1.1	7500	6		○	EEFLS0E181R	3500
ST	2	330	7.3	4.3	1.4	7500	6	○		EEFST0D331R	3500
	2.5	270	7.3	4.3	1.4	7500	6	○		EEFST0E271R	3500
LT	2	330	7.3	4.3	1.4	7500	6		○	EEFLT0D331R	3500
	2.5	270	7.3	4.3	1.4	7500	6		○	EEFLT0E271R	3500

※1:Ripple current (100 kHz/ +45 °C)

※2:ESR (100 kHz/+20 °C)

※3:Please contact us when 500 pcs packing is necessary

◆Please refer to the P16 in this catalog for "Reflow conditions" and "Taping specifications".

Temperature coefficient of Ripple current

Temperature	T ≤ 45 °C	45 °C < T ≤ 85 °C	85 °C < T ≤ 105 °C
Coefficient	1.0	0.7	0.25



Super low ESR(3 mΩ max.)

High ripple current(10200 mA rms max.)

Large capacitance(820 μF max.)

RoHS compliance, Halogen free

SP-Cap

- Guidelines and Precautions
- Mounting specifications
- Packing specifications
- Line-up
- Series system diagram
- Products list
- CS/CT/CX
- SX
- GX/GX-L
- LX
- SR/LR/SS/LS/ST/LT
- GY
- CY/SY
- JX
- HX
- Catalog EOL models

Specifications

Items	Specifications	
Series	GY	
Category temperature range	-55 °C to 105 °C	
Rated voltage range	2 V, 2.5 V	
Rated capacitance range	680 μF to 820 μF	
Capacitance tolerance	±20 %(120 Hz/+20 °C)	
Leakage current	$I \leq 0.1 CV (\mu A)$ [2 minutes]	
Dissipation factor(tanδ)	$\leq 0.06(120 \text{ Hz}/+20 \text{ }^\circ\text{C})$	
Surge voltage(V)	Rated voltage $\times 1.25$ (15 °C to 35 °C)	
Endurance	+105 °C, 2000 h, rated voltage applied	
	Capacitance change	Within ±20 % of the initial value
	tanδ	≤ 2 times of the initial limit
	DC leakage current	≤ 3 times of the initial limit
Damp heat(Steady state)	+60 °C, 90 % RH, 500 h, No-applied voltage	
	Capacitance change of initial measurd value	2 V, 2.5 V +70 %, -20 %
	tan δ	≤ 2 times of the initial limit
	DC leakage current	Within the initial limit

Marking and Dimensions

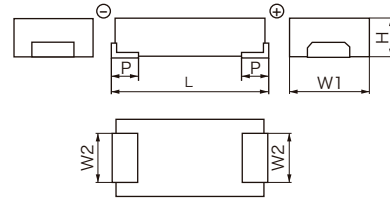
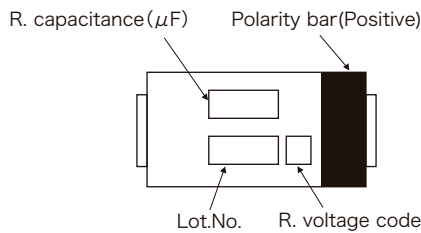

Rated voltage(V)	2	2.5
Code	d	e

Series	L ±0.2	W1 ±0.2	W2 ±0.1	H ±0.2	P ±0.3
GY	7.3	4.3	2.4	2.8	1.3

※Externals of figure are the reference.

Characteristics list

Series	Rated voltage (V)	Capacitance (μF)	Case size (mm)			Specifications		Part number	Min. Packaging Q'ty (pcs)
			L	W	H	Ripple current ※1 (mA rms)	ESR ※2 (mΩ max.)		
GY	2	820	7.3	4.3	2.8	10200	3	EEFGY0D821R	2000
	2.5	680	7.3	4.3	2.8	10200	3	EEFGY0E681R	2000

※1:Ripple current(100 kHz/ +45°C)

※2:ESR(100 kHz/+20 °C)

◆Please refer to the P16 in this catalog for "Reflow conditions" and "Taping specifications".

Temperature coefficient of Ripple current

Temperature	T ≤ 45 °C	45 °C < T ≤ 85 °C	85 °C < T ≤ 105 °C
Coefficient	1.0	0.7	0.25



- Endurance 85 °C 2000 h
- High ripple current (5100 mA rms to 6300 mA rms max.)
- Product height(3.0 mm max.)
- RoHS compliance, Halogen free

Specifications		
Items	Specifications	
Series	CY, SY	
Category temperature range	-55 °C to 85 °C	
Rated voltage range	4 V, 6.3 V	
Rated capacitance range	330 μF to 470 μF	
Capacitance tolerance	±20 % (120 Hz/+20 °C)	
Leakage current	$I \leq 0.1 CV(\mu A)$ [2 minutes]	
Dissipation factor(tanδ)	≤ 0.06 (120 Hz/+20 °C)	
Surge voltage(V.)	Rated voltage × 1.25 (15 °C to 35 °C)	
Endurance	+85 °C, 2000 h, rated voltage applied	
	Capacitance change	Within ±20 % of the initial value
	tanδ	≤ 2 times of the initial limit
	DC leakage current	≤ 3 times of the initial limit
Damp heat (Steady state)	+60 °C, 90 % RH, 500 h, No-applied voltage	
	Capacitance change of initial measurd value	4 V: +60 %, -20 % 6.3 V: +50 %, -20 %
	tan δ	≤ 2 times of the initial limit
	DC leakage current	Within the initial limit

Marking and Dimensions

Rated voltage(V)	4	6.3
Code	g	j

Series	L ±0.2	W1 ±0.2	W2 ±0.1	H ±0.2	P ±0.3
CY/SY	7.3	4.3	2.4	2.8	1.3

(Unit : mm)

※Externals of figure are the reference.

Characteristics list

Series	Rated voltage (V)	Capacitance (μF)	Case size (mm)			Specifications		Part number	Min. Packaging Q'ty ※3 (pcs)
			L	W	H	Ripple current ※1 (mA rms)	ESR ※2 (mΩ max.)		
CY	4	470	7.3	4.3	2.8	5100	15	ECGCY0G471R	2000
	6.3	330	7.3	4.3	2.8	5100	15	ECGCY0J331R	2000
SY	4	470	7.3	4.3	2.8	6300	9	ECGSY0G471R	2000
	6.3	330	7.3	4.3	2.8	6300	9	ECGSY0J331R	2000

- ※1: Ripple current (100 kHz/ +45°C)
- ※2: ESR (100 kHz/+20 °C)
- ※3: Please contact us when 500 pcs packing is necessary.
- ◆ Please refer to the P16 in this catalog for "Reflow conditions" and "Taping specifications".

Temperature coefficient of Ripple current

Temperature	T ≤ 45 °C	45 °C < T ≤ 65 °C	65 °C < T ≤ 85 °C
Coefficient	1.0	0.7	0.25

SP-Cap

- Guidelines and Precautions
- Mounting specifications
- Packing specifications
- Line-up
- Series system diagram
- Products list
- CS/CT/CX
- SX
- GX/GX-L
- LX
- SR/LR/SS/LS/ST/LT
- GY
- CY/SY**
- JX
- HX
- Catalog EOL models

POSCAP

- Guidelines and Precautions
- Mounting specifications
- Packing specifications
- Selection guide

Surface mount type

- Catalog Deletion models
- Catalog EOL models

OS-CON

- Guidelines and Precautions
- Mounting specifications
- Packing specifications
- Selection guide

Surface mount type

Radial lead type

Catalog EOL models

Hybrid

- Guidelines and Precautions
- Mounting specifications
- Packing specifications
- Selection guide

Surface mount type

Radial lead type



Endurance 125 °C 3000 h

Damp heat 85 °C 85% 1000 h

Low ESR(9 mΩ max.)

RoHS compliance, Halogen free

SP-Cap

- Guidelines and Precautions
- Mounting specifications
- Packing specifications
- Line-up
- Series system diagram
- Products list
- CS/CT/CX
- SX
- GX/GX-L
- LX
- SR/LR/SS/LS/ST/LT
- GY
- CY/SY
- JX
- HX
- Surface mount type
- Catalog EOL models

POSCAP

- Guidelines and Precautions
- Mounting specifications
- Packing specifications
- Selection guide
- Surface mount type

- Catalog Deletion models
- Catalog EOL models

OS-CON

- Guidelines and Precautions
- Mounting specifications
- Packing specifications
- Selection guide
- Surface mount type

Specifications

Items	Specifications	
Series	JX	
Category temperature range	-55 °C to 125 °C	
Rated voltage range	2 V, 2.5 V	
Rated capacitance range	220 μF to 470 μF	
Capacitance tolerance	±20 % (120 Hz/+20 °C)	
Leakage current	$I \leq 0.1 CV(\mu A)$, 2 minutes	
Dissipation factor(tanδ)	≤ 0.1 (120 Hz/+20 °C)	
Surge voltage(V)	Rated voltage x1.25 (15 °C to 35 °C)	
Endurance	+125 °C, 3000 h, Category voltage applied	
	Capacitance change	Within ±20 % of the initial value
	tanδ	≤ 2 times of the initial limit
	DC leakage current	Within the initial limit
Damp heat(Steady state)	+85 °C, 85 % RH, 1000 h, No-applied voltage	
	Capacitance change of initial measurd value	2 V, 2.5 V +70 %, -20 %
	tan δ	≤ 2 times of the initial limit
	DC leakage current	≤ 5 times of the initial limit

Marking and Dimensions

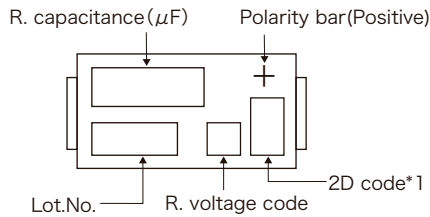

Rated voltage(V)	2	2.5
Code	d	e

*1. Internal management information

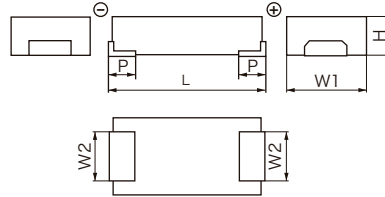

(Unit : mm)

Series	L ±0.2	W1 ±0.2	W2 ±0.1	H ±0.1	P ±0.3
JX	7.3	4.3	2.4	1.9	1.3

※Externals of figure are the reference

Radial lead type

Catalog EOL models

Hybrid

- Guidelines and Precautions
- Mounting specifications
- Packing specifications
- Selection guide
- Surface mount type

Radial lead type

Characteristics list

Series	Rated voltage (V)	Capacitance (μF)	Case size (mm)			Specifications		Part number	Min. Packaging Qty (pcs)
			L	W	H	Ripple current ※1 (mA rms)	ESR ※2 (mΩ max.)		
JX	2	330	7.3	4.3	1.9	6300	9	EEFJX0D331RE	3500
		470	7.3	4.3	1.9	6300	9	EEFJX0D471RE	3500
	2.5	220	7.3	4.3	1.9	6300	9	EEFJX0E221RE	3500
		330	7.3	4.3	1.9	6300	9	EEFJX0E331RE	3500
		390	7.3	4.3	1.9	6300	9	EEFJX0E391RE	3500

※1: Ripple current (100 kHz/ +45 °C)

※2: ESR (100 kHz/+20 °C)

◆Please refer to the P16 in this catalog for "Reflow conditions" and "Taping specifications".

Temperature coefficient of Ripple current

Temperature		T ≤ 45 °C	45 °C < T ≤ 85 °C	85 °C < T ≤ 105 °C	105 °C < T ≤ 125 °C
2V, 2.5V	Coefficient	1.0	0.7	0.25	0.25

SP-Cap

- Guidelines and Precautions
- Mounting specifications
- Packing specifications
- Selection guide
- Line-up
- Series system diagram
- Products list
- CS/CT/CX
- SX
- GX/GX-L
- LX
- SR/LR/SS/LS/ST/LT
- GY
- CY/SY
- JX**
- HX
- Catalog EOL models

POSCAP

- Guidelines and Precautions
- Mounting specifications
- Packing specifications
- Selection guide

Selection guide

Surface mount type

Catalog Deletion models
Catalog EOL models

OS-CON

- Guidelines and Precautions
- Mounting specifications
- Packing specifications
- Selection guide

Selection guide

Surface mount type

Radial lead type

Catalog EOL models

Hybrid

- Guidelines and Precautions
- Mounting specifications
- Packing specifications
- Selection guide

Selection guide

Surface mount type

Radial lead type



Endurance 125 °C 1000 h

Low ESR(4.5 mΩ max.)

RoHS compliance, Halogen free

- SP-Cap
- Guidelines and Precautions
- Mounting specifications
- Packing specifications
- Line-up
- Series system diagram
- Products list
- CS/CT/CX
- SX
- GX/GX-L
- LX
- SR/LR/SS/LS/ST/LT
- GY
- CY/SY
- JX
- HX
- Selection guide
- Surface mount type
- Catalog EOL models

Specifications

Items	Specifications		
Series	HX		
Category temperature range	-55 °C to 125 °C		
Rated voltage range	2 V, 2.5 V / 10 V to 25 V		
Category voltage range	1.6 V, 2 V / 8 V to 20 V		
Rated capacitance range	15 μF to 470 μF		
Capacitance tolerance	±20 % (120 Hz/20 °C)		
Leakage current	$I \leq 0.1 CV(\mu A)$ [2 V, 2.5 V, 2 minutes], $I \leq 0.3 CV(\mu A)$ [10 V to 25 V, 2 minutes]		
Dissipation factor(tanδ)	≤ 0.1 (120 Hz/20 °C)		
Surge voltage(V)	Rated voltage × 1.25[2 V to 16 V], × 1.15[20 V to 25 V] (15 °C to 35 °C)		
Endurance	+125 °C, 1000 h, Category voltage applied		
	Capacitance change	Within ±20 % of the initial value	
	tanδ	≤ 2 times of the initial limit	
	DC leakage current	Within the initial limit	
Damp heat(Steady state)	+60 °C, 90 % RH, 500 h, No-applied voltage		
	Capacitance change of initial measurd value	2 V, 2.5 V	10 V to 25 V
		+70 %, -20 %	+60 %, -20 %
	tan δ	≤ 2 times of the initial limit	
DC leakage current	Within the initial limit[2 V, 2.5 V], ≤ 300 % of the initial limit[10 V to 25 V]		

- POSCAP
- Guidelines and Precautions
- Mounting specifications
- Packing specifications
- Selection guide
- Surface mount type
- Catalog Deletion models
- Catalog EOL models

Marking and Dimensions

R. capacitance(μF) Polarity bar(Positive)

Lot.No. R. voltage code

(Unit : mm)

Rated voltage(V)	2	2.5	10	16	20	25
Code	d	e	A	C	D	E

Series	L ±0.2	W1 ±0.2	W2 ±0.1	H ±0.1	P ±0.3
HX	7.3	4.3	2.4	1.9	1.3

- OS-CON
- Guidelines and Precautions
- Mounting specifications
- Packing specifications
- Selection guide
- Surface mount type
- Radial lead type
- Catalog EOL models
- Hybrid
- Guidelines and Precautions
- Mounting specifications
- Packing specifications
- Selection guide
- Surface mount type
- Radial lead type

Characteristics list (2 to 2.5 V)

Series	Rated voltage [105 °C] (V)	Category voltage [125 °C] (V)	Capacitance (μF)	Case size (mm)			Specifications		Part number	Min. Packaging Q'ty ※3 (pcs)
				L	W	H	Ripple current ※1 (mA rms)	ESR ※2 (mΩ max.)		
HX	2	1.6	470	7.3	4.3	1.9	5100	15	EEFH0D471R	3500
				7.3	4.3	1.9	6300	9	EEFH0D471R9	3500
				7.3	4.3	1.9	7500	6	EEFH0D471R6	3500
				7.3	4.3	1.9	8500	4.5	EEFH0D471R4	3500
	2.5	2	330	7.3	4.3	1.9	5100	15	EEFH0E331R	3500
				7.3	4.3	1.9	6300	9	EEFH0E331R9	3500
				7.3	4.3	1.9	7500	6	EEFH0E331R6	3500
				7.3	4.3	1.9	8500	4.5	EEFH0E331R4	3500

Characteristics list (10 to 25 V) Not Recommended for New Design

Series	Rated voltage [105 °C] (V)	Category voltage [125 °C] (V)	Capacitance (μF)	Case size (mm)			Specifications		Part number	Min. Packaging Q'ty ※3 (pcs)
				L	W	H	Ripple current ※1 (mA rms)	ESR ※2 (mΩ max.)		
HX	10	8	47	7.3	4.3	1.9	3200	40	EEFH1A470R	3500
			68	7.3	4.3	1.9	3200	40	EEFH1A680R	3500
			100	7.3	4.3	1.9	3200	40	EEFH1A101R	3500
	16	12.8	15	7.3	4.3	1.9	3200	40	EEFH1C150R	3500
			22	7.3	4.3	1.9	3200	40	EEFH1C220R	3500
			33	7.3	4.3	1.9	3200	40	EEFH1C330R	3500
			47	7.3	4.3	1.9	3200	40	EEFH1C470R	3500
			68	7.3	4.3	1.9	3200	40	EEFH1C680R	3500
	20	16	22	7.3	4.3	1.9	3200	40	EEFH1D220R	3500
			33	7.3	4.3	1.9	3200	40	EEFH1D330R	3500
			47	7.3	4.3	1.9	3200	40	EEFH1D470R	3500
			56	7.3	4.3	1.9	3200	40	EEFH1D560R	3500
	25	20	15	7.3	4.3	1.9	3200	40	EEFH1E150R	3500
			22	7.3	4.3	1.9	3200	40	EEFH1E220R	3500
			33	7.3	4.3	1.9	3200	40	EEFH1E330R	3500

※1:Ripple current (100 kHz/ +45 °C)

※2:ESR (100 kHz/+20 °C)

※3:Please contact us when 500 pcs packing is necessary

◆Please refer to the P16 in this catalog for "Reflow conditions" and "Taping specifications".

Temperature coefficient of Ripple current

Temperature		T ≤ 45 °C	45 °C < T ≤ 85 °C	85 °C < T ≤ 105 °C	105 °C < T ≤ 125 °C
2 V, 2.5 V	Coefficient	1.0	0.7	0.25	0.25
10 V to 25 V		1.0	0.8	0.5	0.25

Catalog EOL models



Guidelines and Precautions
Mounting specifications
Packing specifications

Line-up

Series system diagram
Products list

CS/CT/CX
SX
GX/GX-L
LX
SR/LR/SS/LS/ST/LT
GY
CY/SY
JX
HX

Selection guide

Surface mount type

Catalog EOL models



Guidelines and Precautions
Mounting specifications
Packing specifications

Selection guide

Surface mount type

Catalog Deletion models
Catalog EOL models



Guidelines and Precautions
Mounting specifications
Packing specifications

Selection guide

Surface mount type

Radial lead type

Catalog EOL models



Guidelines and Precautions
Mounting specifications
Packing specifications

Selection guide

Surface mount type

Radial lead type

The following table is a list of the End-Of-Life (EOL) models.

Sales of these items will end as soon as we run out of its stock.

We would like to express our appreciation for your business over the years with these products and we hope the new, alternative parts will continue to serve your needs.

Thank you very much.

Series	Size code	Models for deletion	Year of deletion	Alternative model
FD	D	EEFFD*****	2019/3	EEFCS*****
CD	D	EEFCD*****	2019/3	EEFCX*****
UD	D	EEFUD*****	2019/3	EEFCX*****
UE	D	EEFUE*****	2019/3	EEFCX*****
SL	D	EEFSL*****	2019/3	EEFSX*****
SD	D	EEFSD*****	2010/6	EEFSX*****
SE	D	EEFSE*****	2019/3	EEFSX*****
MC	C	EEFMC*****	2019/3	EEFCX*****
HL	D	EEFHL*****	2019/3	EEFHX*****
HD	D	EEFHD*****	2019/3	EEFHX*****
HE	D	EEFHE*****	2019/3	EEFHX*****

Not recommended for new design

Replacement list for “Not recommended for new design”

If you are using any of the following models on the deleted list, please substitute them with the suggested alternative model as soon as possible.

Non-recommended part number						Replacement part number						
Series	Category temp. range max. (°C)	Rated voltage (V)	Capacitance (μF)	ESR (mΩ)	Part number	Series	Size code	Category temp. range max. (°C)	Rated voltage (V)	Capacitance (μF)	ESR (mΩ)	Part number
CS	105	10	47	40	EEFCS1A470R	POSCAP TQC	D12	105	16	33	40	16TQC33MYFS
						POSCAP TPG	B1G	85	10	47	70	10TPG47M
						OS-CON SVP	C6	105	10	47	50	10SVP47M
						Hybrid ZA	D	105	25	47	50	EEHZA1E470P
	105	16	15	40	EEFCS1C150R	POSCAP TQC	D12	105	16	33	40	16TQC33MYFS
						OS-CON SVP	B6	105	16	22	90	16SVP22M
						Hybrid ZA	C	105	25	22	80	EEHZA1E220R
						POSCAP TQC	D12	105	16	33	40	16TQC33MYFS
	105	16	22	40	EEFCS1C220R	OS-CON SVP	B6	105	16	22	90	16SVP22M
						Hybrid ZA	C	105	25	22	80	EEHZA1E220R
						POSCAP TQC	D12	105	16	33	40	16TQC33MYFS
						OS-CON SVPC	B6	105	16	39	27	16SVP39MV
	105	16	33	40	EEFCS1C330R	Hybrid ZA	C	105	25	33	80	EEHZA1E330R
						POSCAP TQC	D15	105	20	47	55	20TQC47MYFT
						OS-CON SVPA	B6	105	20	10	40	20SVP10M
						Hybrid ZA	C	105	35	10	100	EEHZA1V100R
	105	20	10	40	EEFCS1D100R	POSCAP TQC	D15	105	20	47	55	20TQC47MYFT
						OS-CON SVPB	C5	105	20	15	45	20SVPB15M
						Hybrid ZA	C	105	25	22	80	EEHZA1E220R
						POSCAP TQC	D15	105	20	47	55	20TQC47MYFT
	105	20	15	40	EEFCS1D150R	OS-CON SVPA	C6	105	20	22	35	20SVP22M
						Hybrid ZA	C	105	25	22	80	EEHZA1E220R
						POSCAP TQC	D15	105	20	47	55	20TQC47MYFT
						OS-CON SVPA	C6	105	20	22	35	20SVP22M
105	20	22	40	EEFCS1D220R	Hybrid ZA	C	105	25	22	80	EEHZA1E220R	
					POSCAP TQC	D15	105	25	22	70	25TQC22MYFT	
					POSCAP TQC	D2	105	25	15	45	25TQC15MV	
					OS-CON SVPD	C6	125	25	10	65	25SVPD10M	
105	25	10	40	EEFCS1E100R	Hybrid ZA	C	105	35	10	100	EEHZA1V100R	
					POSCAP TQC	D15	105	25	22	70	25TQC22MYFT	
					POSCAP TQC	D2	105	25	15	45	25TQC15MV	
					OS-CON SVPG	B45	105	25	15	30	25SVPG15M	
105	25	15	40	EEFCS1E150R	Hybrid ZA	C	105	25	22	80	EEHZA1E220R	
					POSCAP TQC	D2	105	35	10	120	35TQC10MYF	
					OS-CON SVPK	B6	125	35	22	35	35SVPK22M	
					Hybrid ZA	C	105	35	10	100	EEHZA1V100R	
105	35	10	40	EEFCS1V100R	POSCAP TQC	D15	105	16	47	55	16TQC47MYFT	
					POSCAP TPE	D2E	105	10	68	25	10TPE68M	
					OS-CON SVPC	B6	105	10	68	30	10SVP68M	
					Hybrid ZA	D8	105	25	68	30	EEHZA1E680XP	
CT	105	10	68	40	EEFCT1A680R	Hybrid ZA	D8	105	35	68	35	EEHZA1V680XP
						POSCAP TQC	D15	105	16	47	55	16TQC47MYFT
						OS-CON SVPG	B45	105	16	47	25	16SVPG47M
						Hybrid ZA	D	105	25	47	50	EEHZA1E470P
	105	16	47	40	EEFCT1C470R	POSCAP TQC	D15	105	20	47	55	20TQC47MYFT
						OS-CON SVPG	B45	105	20	33	27	20SVPG33M
						Hybrid ZA	C	105	25	33	80	EEHZA1E330R
						POSCAP TQC	D15	105	20	47	55	20TQC47MYFT
	105	20	33	40	EEFCT1D330R	OS-CON SVPF	C6	105	25	47	30	25SVPF47M
						Hybrid ZA	D	105	25	47	50	EEHZA1E470P
						POSCAP TQC	D15	105	20	47	55	20TQC47MYFT
						OS-CON SVPG	B45	105	20	33	27	20SVPG33M
	105	20	47	40	EEFCT1D470R	Hybrid ZA	C	105	25	22	80	EEHZA1E220R
						POSCAP TQC	D15	105	25	22	70	25TQC22MYFT
						POSCAP TQC	D2	105	25	22	45	25TQC22MV
						OS-CON SVPF	B6	105	25	27	40	25SVPF27MX
	105	25	22	40	EEFCT1E220R	Hybrid ZA	C	105	25	22	80	EEHZA1E220R
						POSCAP TQC	D2	105	35	15	150	35TQC15MYF
						OS-CON SVPK	B6	125	35	22	35	35SVPK22M
						Hybrid ZA	C	105	35	22	100	EEHZA1V220R

SP-Cap

Guidelines and Precautions
Mounting specifications
Packing specifications
Line-up
Series system diagram
Products list
CS/CT/CX
SX
GX/GX-L
LX
SR/LR/SS/LS/ST/LT
GY
CY/SY
JX
HX
Catalog EOL models

POSCAP

Guidelines and Precautions
Mounting specifications
Packing specifications

Selection guide

Surface mount type

Catalog Deletion models
Catalog EOL models

OS-CON

Guidelines and Precautions
Mounting specifications
Packing specifications

Selection guide

Surface mount type

Radial lead type

Catalog EOL models

Hybrid

Guidelines and Precautions
Mounting specifications
Packing specifications

Selection guide

Surface mount type

Radial lead type

Not recommended for new design

SP-Cap

Guidelines and Precautions
Mounting specifications
Packing specifications

Line-up

Series system diagram

Products list

CS/CT/CX
SX
GX/GX-L
LX
SR/LR/SS/LS/ST/LT
GY
CY/SY
JX
HX

Selection guide

Surface mount type

Catalog EOL models

POSCAP

Guidelines and Precautions
Mounting specifications
Packing specifications

Selection guide

Surface mount type

Catalog Deletion models
Catalog EOL models

OS-CON

Guidelines and Precautions
Mounting specifications
Packing specifications

Selection guide

Surface mount type

Radial lead type

Catalog EOL models

Hybrid

Guidelines and Precautions
Mounting specifications
Packing specifications

Selection guide

Surface mount type

Radial lead type

Non-recommended part number						Replacement part number						
Series	Category temp. range max. (°C)	Rated voltage (V)	Capacitance (μF)	ESR (mΩ)	Part number	Series	Size code	Category temp. range max. (°C)	Rated voltage (V)	Capacitance (μF)	ESR (mΩ)	Part number
CX	105	10	100	40	EEFCX1A101R	POSCAP TPC	D2	105	10	100	45	10TPC100M
						OS-CON SVPC	C6	105	10	120	22	10SVPC120MV
						Hybrid ZA	D8	105	25	100	30	EEHZA1E101XP
	105	10	47	40	EEFCX1A470R	POSCAP TPE	D2E	105	10	68	25	10TPE68M
						POSCAP TPE	B2	85	10	47	35	10TPE47MAZB
						OS-CON SVP	C6	105	10	47	50	10SVP47M
						Hybrid ZA	D	105	25	47	50	EEHZA1E470P
	105	10	68	40	EEFCX1A680R	POSCAP TPE	D2E	105	10	68	25	10TPE68M
						POSCAP TQC	D2	105	16	68	50	16TQC68MYF
						OS-CON SVPC	B6	105	10	68	23	10SVPC68MV
						Hybrid ZA	D8	105	25	68	30	EEHZA1E680XP
	105	16	15	40	EEFCX1C150R	Hybrid ZA	D8	105	35	68	35	EEHZA1V680XP
						POSCAP TQC	D2	105	16	47	40	16TQC47MW
						POSCAP TQC	B2	105	16	15	90	16TQC15M
						OS-CON SVP	B6	105	16	22	90	16SVP22M
	105	16	22	40	EEFCX1C220R	Hybrid ZA	C	105	25	22	80	EEHZA1E220R
						POSCAP TQC	D2	105	16	47	40	16TQC47MW
						POSCAP TQC	B2	105	16	22	90	16TQC22MYFB
						OS-CON SVP	B6	105	16	22	90	16SVP22M
	105	16	33	40	EEFCX1C330R	Hybrid ZA	C	105	25	22	80	EEHZA1E220R
						POSCAP TQC	D2	105	16	47	40	16TQC47MW
						POSCAP TQC	B2	105	16	33	90	16TQC33MYFB
						OS-CON SVPC	B6	105	16	39	27	16SVPC39MV
	105	16	47	40	EEFCX1C470R	Hybrid ZA	C	105	25	33	80	EEHZA1E330R
						POSCAP TQC	D2	105	16	47	40	16TQC47MW
						OS-CON SVPG	B45	105	16	47	25	16SVPG47M
						Hybrid ZA	D	105	25	47	50	EEHZA1E470P
	105	16	68	40	EEFCX1C680R	POSCAP TQC	D2	105	16	68	50	16TQC68MYF
						POSCAP TQC	D2	105	16	100	50	16TQC100MYF
						OS-CON SVPC	C6	105	16	68	25	16SVPC68MV
						Hybrid ZA	D8	105	25	68	30	EEHZA1E680XP
	105	20	22	40	EEFCX1D220R	Hybrid ZA	D8	105	35	68	35	EEHZA1V680XP
						POSCAP TQC	D2	105	20	33	60	20TQC33MYFD
						POSCAP TQC	B2	105	20	22	90	20TQC22MYFB
						OS-CON SVPA	C6	105	20	22	35	20SVPA22M
	105	20	33	40	EEFCX1D330R	Hybrid ZA	C	105	25	22	80	EEHZA1E220R
						POSCAP TQC	D2	105	20	33	60	20TQC33MYFD
						POSCAP TQC	D2	105	20	47	55	20TQC47MYF
						OS-CON SVPG	B45	105	20	33	27	20SVPG33M
	105	20	47	40	EEFCX1D470R	Hybrid ZA	C	105	25	33	80	EEHZA1E330R
						POSCAP TQC	D15	105	20	47	55	20TQC47MYFT
						OS-CON SVPF	C6	105	25	47	30	25SVPF47M
						Hybrid ZA	D	105	25	47	50	EEHZA1E470P
	105	20	56	40	EEFCX1D560R	POSCAP TQC	D2	105	20	100	100	20TQC100MD2
						OS-CON SVPF	B6	105	20	56	30	20SVPF56MX
						Hybrid ZA	C	105	25	56	50	EEHZA1E550P
						POSCAP TQC	D2	105	25	15	45	25TQC15MV
	105	25	15	40	EEFCX1E150R	POSCAP TQC	B2	105	25	15	100	25TQC15MYFB
OS-CON SVPF						B45	105	25	15	30	25SVPG15M	
Hybrid ZA						C	105	25	22	80	EEHZA1E220R	
POSCAP TQC						D2	105	25	22	45	25TQC22MV	
105	25	22	40	EEFCX1E220R	OS-CON SVPF	B6	105	25	27	40	25SVPF27MX	
					Hybrid ZA	C	105	25	22	80	EEHZA1E220R	
					POSCAP TQC	D2	105	25	33	60	25TQC33MYF	
					OS-CON SVPK	B6	125	25	33	35	25SVPK33M	
105	25	33	40	EEFCX1E330R	Hybrid ZA	C	105	25	33	80	EEHZA1E330R	
					POSCAP TQC	D2	105	35	15	150	35TQC15MYF	
					OS-CON SVPK	B6	125	35	22	35	35SVPK22M	
					Hybrid ZA	C	105	35	22	100	EEHZA1V220R	
105	35	15	40	EEFCX1V150R	POSCAP TQC	D2	105	35	15	150	35TQC15MYF	
					OS-CON SVPK	B6	125	35	22	35	35SVPK22M	
					Hybrid ZA	C	105	35	22	100	EEHZA1V220R	
					POSCAP TQC	D2	105	35	15	150	35TQC15MYF	
105	35	22	40	EEFCX1V220R	OS-CON SVPK	B6	125	35	22	35	35SVPK22M	
					Hybrid ZA	C	105	35	22	100	EEHZA1V220R	

Non-recommended part number					Replacement part number							
Series	Category temp. range max. (°C)	Rated voltage (V)	Capacitance (μF)	ESR (mΩ)	Part number	Series	Size code	Category temp. range max. (°C)	Rated voltage (V)	Capacitance (μF)	ESR (mΩ)	Part number
HX	125	10	47	40	EEFHX1A470R	POSCAP TDC	D2	125	16	100	50	16TDC100MYF
						POSCAP THC	D2	105	10	68	45	10THC68M
						OS-CON SVPD	C6	125	10	56	45	10SVPD56M
	125	10	68	40	EEFHX1A680R	Hybrid ZC	D	125	25	47	50	EEHXC1E470P
						POSCAP TDC	D2	125	16	100	50	16TDC100MYF
						POSCAP THC	D2	105	10	68	45	10TCH68M
	125	10	100	40	EEFHX1A101R	OS-CON SVPK	B6	125	20	68	30	20SVPK68M
						Hybrid ZC	D8	125	25	68	30	EEHXC1E680XP
						POSCAP TDC	D2	125	16	100	50	16TDC100MYF
	125	10	100	40	EEFHX1A101R	POSCAP TCF	D3L	105	10	150	15	10TCF150ML
						OS-CON SVPK	B6	125	16	100	27	16SVPK100M
						Hybrid ZC	D8	125	25	100	30	EEHXC1E101XP
	125	16	15	40	EEFHX1C150R	POSCAP TDC	D2	125	16	100	50	16TDC100MYF
						POSCAP TDC	B2	125	16	33	90	16TDC33MYFB
						Hybrid ZC	C	125	25	22	80	EEHXC1E220R
	125	16	22	40	EEFHX1C220R	POSCAP TDC	D2	125	16	100	50	16TDC100MYF
						POSCAP TDC	B2	125	16	33	90	16TDC33MYFB
						OS-CON SVPK	B6	125	35	22	35	35SVPK22M
	125	16	33	40	EEFHX1C330R	Hybrid ZC	C	125	25	22	80	EEHXC1E220R
						POSCAP TDC	D2	125	16	100	50	16TDC100MYF
						POSCAP TDC	B2	125	16	33	90	16TDC33MYFB
	125	16	47	40	EEFHX1C470R	OS-CON SVPK	B6	125	25	33	35	25SVPK33M
						Hybrid ZC	C	125	25	33	80	EEHXC1E330R
						POSCAP TDC	D2	125	16	100	50	16TDC100MYF
	125	16	68	40	EEFHX1C680R	OS-CON SVPK	C6	125	35	47	27	35SVPK47M
						Hybrid ZC	D	125	25	47	50	EEHXC1E470P
						POSCAP TDC	D2	125	16	100	50	16TDC100MYF
	125	20	22	40	EEFHX1D220R	OS-CON SVF	B6	125	16	82	27	16SVF82M
						OS-CON SVPK	B6	125	35	22	35	35SVPK22M
						Hybrid ZC	D8	125	25	68	30	EEHXC1E680XP
	125	20	33	40	EEFHX1D330R	POSCAP TDC	B2	125	20	22	90	20TDC22MYFB
						OS-CON SVPK	B6	125	25	33	35	25SVPK33M
						Hybrid ZC	C	125	25	33	80	EEHXC1E330R
	125	20	47	40	EEFHX1D470R	OS-CON SVPK	C6	125	35	47	27	35SVPK47M
						Hybrid ZC	D	125	25	47	50	EEHXC1E470P
						OS-CON SVF	B6	125	20	56	30	20SVF56M
	125	20	56	40	EEFHX1D560R	Hybrid ZC	D	125	25	56	50	EEHXC1E560P
						POSCAP TDC	D3L	125	25	68	70	25TDC68MYF
						POSCAP TDC	B2	125	25	15	100	25TDC15MYFB
	125	25	15	40	EEFHX1E150R	OS-CON SPF	B6	125	25	27	40	25SVF27M
						Hybrid ZC	C	125	25	22	80	EEHXC1E220R
						POSCAP TDC	D3L	125	25	68	70	25TDC68MYF
125	25	22	40	EEFHX1E220R	OS-CON SVF	B6	125	25	27	40	25SVF27M	
					Hybrid ZC	C	125	25	22	80	EEHXC1E220R	
					POSCAP TDC	D3L	125	25	68	70	25TDC68MYF	
125	25	33	40	EEFHX1E330R	OS-CON SVPK	B6	125	25	33	35	25SVPK33M	
					Hybrid ZC	C	125	25	33	80	EEHXC1E330R	

SP-Cap

Guidelines and Precautions
Mounting specifications
Packing specifications

Line-up
Series system diagram

Products list

CS/CT/CX

SX

GX/GX-L

LX

SR/LR/SS/LS/ST/LT

GY

CY/SY

JX

HX

Catalog EOL models

Selection guide

Surface mount type

Radial lead type

Catalog EOL models

Selection guide

Surface mount type

Radial lead type

Catalog EOL models

Selection guide

Surface mount type

Radial lead type

Catalog EOL models

Selection guide

Surface mount type

Radial lead type

Catalog EOL models

Selection guide

Surface mount type

Radial lead type

Catalog EOL models

Selection guide

Surface mount type

Radial lead type

Catalog EOL models

Selection guide

Surface mount type

Radial lead type

Catalog EOL models

Selection guide

Surface mount type

Radial lead type

Catalog EOL models

Selection guide

Surface mount type

Radial lead type

Catalog EOL models

Selection guide

Surface mount type

Radial lead type

Catalog EOL models

Selection guide

Surface mount type

Radial lead type

Catalog EOL models

Selection guide

Surface mount type

Radial lead type

Catalog EOL models

Selection guide

Surface mount type

Radial lead type

Catalog EOL models

Selection guide

Surface mount type

Radial lead type

Catalog EOL models

Selection guide

Surface mount type

Radial lead type



Conductive Polymer Tantalum Solid Capacitors

POSCAP™

INDEX

Guidelines and Precautions	P41
Mounting specifications / Packing specifications	P43
Selection guide	P45
Products list	P51
Catalog deletion models	P71
Catalog EOL models	P72

SP-Cap

Guidelines and Precaution
Mounting specifications
Packing specifications

Selection guide

Surface mount type

Catalog EOL models

POSCAP

Guidelines and Precautions
Mounting specifications
Packing specifications

Selection guide
Line-up
Series system diagram
Size list
Products list

TPG
TPS
TPSF
TQS
TPE
TPF
TQC
TA
TV
TH
TPB
TC
TDC
TPC

Surface mount type

Catalog Deletion models

Catalog EOL models

OS-CON

Guidelines and Precautions
Mounting specifications
Packing specifications

Selection guide

Surface mount type

Radial lead type

Catalog EOL models

Hybrid

Guidelines and Precautions
Mounting specifications
Packing specifications

Selection guide

Surface mount type

Radial lead type

Applications

Main market

Laptop computer



Communications infrastructure

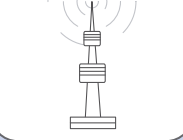

SSD, HDD

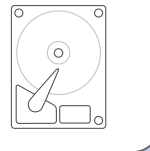

Audio / Visual

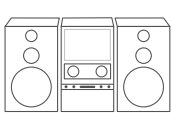

Server



Automotive



Industrial robot

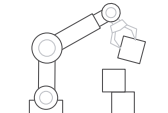

Drone



Guidelines and Precautions

SP-Cap

Guidelines and Precautions
Mounting specifications
Packing specifications

Selection guide

Surface mount type

Catalog EOL models

POSCAP

Guidelines and Precautions
Mounting specifications
Packing specifications

Line-up
Series system diagram
Size list

Products list

TPG
TPS
TPSF
TQS
TPE
TPF
TQC
TA
TV
TH
TPB
TC
TDC
TPC

Surface
mount
type

Catalog Deletion models

Catalog EOL models

OS-CON

Guidelines and Precautions
Mounting specifications
Packing specifications

Selection guide

Surface mount type

Radial lead type

Catalog EOL models

Hybrid

Guidelines and Precautions
Mounting specifications
Packing specifications

Selection guide

Surface mount type

Radial lead type



Application Guidelines

1. Circuit design

1-1 Prohibited circuits

Since problems can be expected, POSCAP cannot be used on the following circuits

- (1) High impedance voltage retention circuits
- (2) Coupling circuits
- (3) Time constant circuits
- (4) Circuits greatly affected by leakage current
- (5) The circuit in which two or more POSCAP are connected in a series so as to raise the endurance voltage.

1-2 Failure and life-span

The failure rate is 0.5 %* / 1000 h (Confidence level : 60 %) based on JIS C 5003.

The mainly failure modes are as follows.

※B2 size or less : 1.0 %

1-2-1 Contingency failure

The main causes of failure are thermal stresses cause by the soldering or thermal use environment, along with heat stresses, electrical stresses or mechanical stresses. The most common failure mode is a short circuit. In case a short circuit occurs, ensure safety by fully considering the followings.

- (1) If POSCAP emit smoke, turn off the main power of the equipment. In this case, keep your face and hands away from the area.
- (2) It may take a few seconds to a few minutes before POSCAP emits smoke by the situation. Increase safety by using a protective circuit.
- (3) If the smoke comes into eyes, rinse immediately. If the smoke is inhaled, gargle immediately.
- (4) In case a large current continues to flow after a short circuit, in the worst case, the shorted-out section may ignite. For safety, install a redundant circuit or a protective circuit, etc.

1-2-2 Wear-out failure (lifetime)

When lifetime exceeded the specified guarantee time of Endurance and Damp heat, electrolyte might insulate and cause electric characteristic changed. This is called an open circuit. The electric characteristics of capacitance and ESR may possibly change within the specified range in specifications when it is used under the condition of the rated voltage, electric and mechanical performance. Please note it when design.

1-3 Reduction of failure stress

When POSCAP is used within the rated voltage, it shows a stable characteristic, but it may be damaged in a short circuit when an overvoltage, for instance, is applied. The time to reach the failure mode can be extended by using POSCAP with reduced environment temperature, ripple current and applied voltage.

Failure rate

In the case of the endurance which is 105 °C 2000 h.

0.5 %/1000 h (Environment temp. : 105 °C, Rated voltage or Category voltage applied)

In the case of the endurance which is 105 °C 1000 h or 125 °C 1000 h.

1.0 %/1000 h (Environment temp. : 105 °C, Rated voltage or Category voltage applied)

In the case of the endurance which is 85 °C 1000 h.

1.0 %/1000 h (Environment temp. : 85 °C, Rated voltage applied)

1-4 Check the rated performance

After checking the operation and installation environments, design the circuit so that it falls within the rated performance range stipulated in this delivery specification.

1-5 Operating temperature and ripple current

- (a) Set the operating temperature so that it falls within the range stipulated in this delivery specification.
- (b) Do not apply current that exceeds the allowable ripple current. Ripple current should be controlled so that surface temperature of a capacitor do not exceed the rated temperature.

(For questions regarding TQC series, please contact us.)

- (c) Specified ESR is a value at the time of shipping from factory. ESR may change upon use conditions.

1-6 Leakage current

Even when the soldering conditions fall within the range of this delivery specifications, leakage current increases a little on occasion. It also increases a little during high temperature storage, high humidity storage and temperature cycling with no voltage applied. In cases such as these, leakage current will decrease by applying voltage under the condition of below the POSCAP's maximum operating temperature.

The speed at which the leakage current is restored is increased by applying voltage when the POSCAP's temperature is close to the maximum operating temperature.

1-7 Rapid charge and discharge limitation

Rapid charge and discharge are restricted (for maintainance of high-proof reliability).

A protective circuit is recommended for when a rapid charge or discharge causes excessive rush current since this is main cause of short circuit and large leakage current. Use a protective circuits in case the rush current value exceeds 20 A*

Be sure to insert a protection resistor of about 1 kΩ for charge and discharge when measuring the leakage current.

2. Mounting

2-1 Protect circuit

The failure mode of POSCAP is the short mode. When it breaks down, short electric current flows to it. POSCAP gives off heat by this short current.

Do the following consideration in design fully for the safety because it has a bad influence on the part around POSCAP due to this heat.

- A protective circuit and a protective device are set up, so as to make the system safer.
- A diffuse circuit and so on is set up, so as to make the system safer such as that a machine may not break down as to the single trouble.

2-2 Considerations when soldering

The soldering conditions are to be within the range prescribed in this delivery specification.

If the specifications are not followed, there is the possibility of degradation of electric characteristic and lifetime when soldering is conducted under conditions that are harsher than those stipulated.

2-3 Others

POSCAP's Electrical characteristics are affected by temperature and frequency fluctuations.

Design circuits after checking the amount of fluctuation.

3. Storage

It is necessary to set an environment to prevent a trouble at the time of soldering by the degradation of solder ability or moisture's getting into the molding resin when POSCAP are stored.

- Please make storage of POSCAP sealing up in the reel and the moisture proof bag at the time of delivery in the following environment. Also, set storage period of unopened as 18 months or shorter after shipment from factory.
 - Room temperature and room humidity (generally : 15 to 35 °C, 45 to 75% RH) are desirable.
 - Place where POSCAP is not exposed by direct sunshine.
- Please unseal the moisture proof bag just before mounting and use up POSCAP in the moisture proof bag. Storage conditions after opening the moisture proof bag are as follows.

Level	Floor life	
	Time	Conditions
2 a	4 weeks	≤ 30 °C/60 %RH
3	168 hours	≤ 30 °C/60 %RH
5	48 hours	≤ 30 °C/60 %RH

POSCAP is not compatible with JEDEC J-STD-020, J-STD-033

Intellectual property right

We, Panasonic Group are providing the product and service that customers can use without anxiety, and are working positively on the protection of our products under intellectual property rights.

Representative patents relating to POSCAP are as follows:

US Patent No. 6858800, 6891717, 7158368, 7326260, 8081421, 8149569, 8456804, 8559166

SP-Cap

Guidelines and Precaution
Mounting specifications
Packing specifications

Selection guide

Surface mount type

Catalog EOL models

POSCAP

Guidelines and Precautions
Mounting specifications
Packing specifications

Selection guide
Line-up
Series system diagram
Size list
Products list

TPG
TPS
TPSF
TQS
TPE
TPF
TQC
TA
TV
TH
TPB
TC
TDC
TPC

Catalog Deletion models

Catalog EOL models

OS-CON

Guidelines and Precautions
Mounting specifications
Packing specifications

Selection guide

Surface mount type

Radial lead type

Catalog EOL models

Hybrid

Guidelines and Precautions
Mounting specifications
Packing specifications

Selection guide

Surface mount type

Radial lead type

Mounting specifications

SP-Cap

Guidelines and Precautions
Mounting specifications
Packing specifications

Selection guide

Surface mount type

Catalog EOL models

POSCAP

Guidelines and Precautions
Mounting specifications
Packing specifications

Line-up
Series system diagram
Size list

Selection guide

Products list

- TPG
- TPS
- TPSF
- TQS
- TPE
- TPF
- TQC
- TA
- TV
- TH
- TPB
- TC
- TDC
- TPC

Surface mount type

Catalog Deletion models

Catalog EOL models

OS-CON

Guidelines and Precautions
Mounting specifications
Packing specifications

Selection guide

Surface mount type

Hybrid

Guidelines and Precautions
Mounting specifications
Packing specifications

Selection guide

Surface mount type

Radial lead type

Recommended soldering condition

■ **Target : TPG, TPS, TPSF, TPE, TPF, TA, series TV, TH, TPB, TC, TPC**

Peak temperature 250 °C lead free reflow soldering profile

The cycles of reflow soldering : Twice (max)

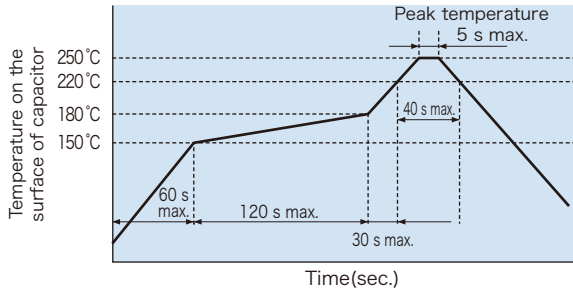

■ **Target : TPG, TPS, TPSF, TPE, TPF, TA, series TV, TPB, TC, TPC**

Peak temperature 260 °C lead free reflow soldering profile

The cycles of reflow soldering : Twice (max)

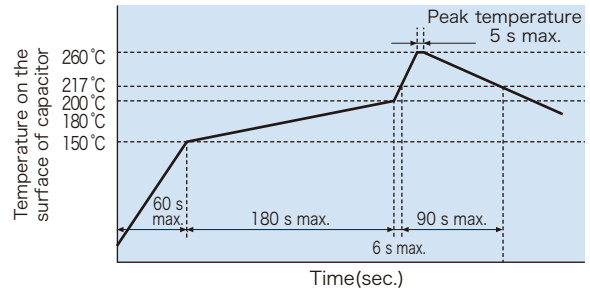

Note) This reflow is limited at moisture sensitive level. Please contact us separately concerning about detail.

■ **Target : TQC, TDC series**

Peak temperature 250 °C lead free reflow soldering profile

The cycles of reflow soldering : Twice (max)

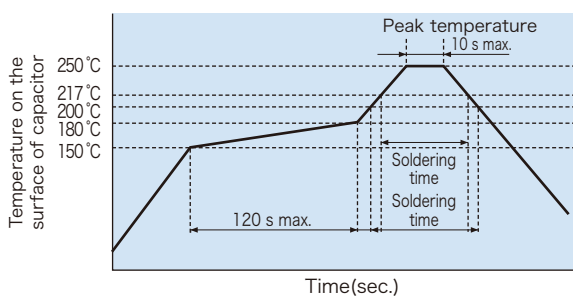

Soldering temperature and soldering time

Temperature	Time	
	16TQC220MD3 25TQC100MD3	Other product numbers
≥ 217 °C	90 s max.	60 s max.
≥ 200 °C	-	70 s max.

■ **Target : TQC (Only the following part number), series TQS**

Peak temperature 260 °C lead free reflow soldering profile

TQC series target : 35TQS47MEU, 25TQC22MYFB, product number 16TQC47MYFB, 35TQC10MYFB, 35TQC10MXB

The cycles of reflow soldering : 3 times (max.)

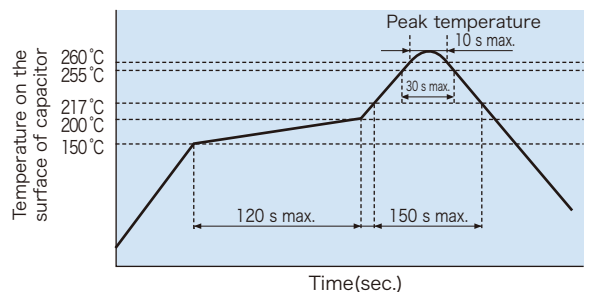

■ **Soldering with a soldering iron**

Tip of a soldering iron : 350 °C max (TQC/TQS serie: 400 °C max) Power of a soldering iron : 30 W max

Working time : 3 sec. max (TQC/TQS serie: 5 sec max)

(Do not let the tip of soldering iron touch the POSCAP itself. Do not subject the POSCAP itself to excessive stress when soldering)

Land/Pad pattern

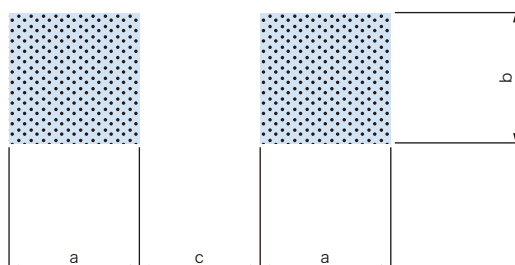

Size code	(unit:mm)		
	a	b	c
B1, B1S, B1G, B2, B2S	1.6	2.7	1.4
D12, D15, D15E, D2E, D2, D3L, D4	2.4	2.9	3.7
D15S	1.4/1.7 ^(*)	2.6	4.6

※1 : +side / -side

Packing specifications

*We supply only embossed tapping type

Packing specifications

Dimension of carrier tape

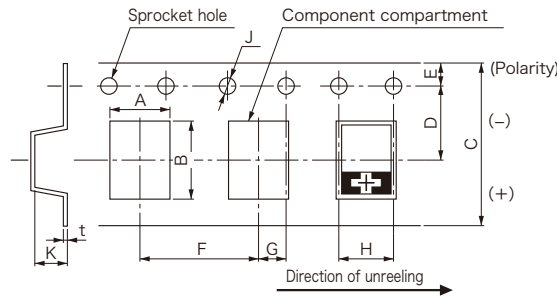

Size code	A ±0.2	B ±0.2	C ±0.3	D ±0.1	E ±0.1	F ±0.1	G ±0.1	H ±0.1	J $^{+0.1}_{-0}$	K ±0.1	t ±0.1
B1	3.2	3.8	8.0	3.5	1.75	4.0	2.0	4.0	φ 1.5	1.4	0.25
B1G	3.25	3.9	8.0	3.5	1.75	4.0	2.0	4.0	φ 1.5	1.7	0.25
B1S	3.25	3.9	8.0	3.5	1.75	4.0	2.0	4.0	φ 1.5	1.7	0.25
B2	3.3	3.8	8.0	3.5	1.75	4.0	2.0	4.0	φ 1.5	2.1	0.25
B2S	3.25	4.0	8.0	3.5	1.75	4.0	2.0	4.0	φ 1.5	2.1	0.25
D12	4.5	7.5	12.0	5.5	1.75	8.0	2.0	4.0	φ 1.5	1.7	0.3
D15	4.5	7.5	12.0	5.5	1.75	8.0	2.0	4.0	φ 1.5	2.4	0.3
D15E, D15S	4.7	7.8	12.0	5.5	1.75	8.0	2.0	4.0	φ 1.5	1.7	0.3
D2E	4.5	7.5	12.0	5.5	1.75	8.0	2.0	4.0	φ 1.5	2.4	0.3
D2	4.5	7.5	12.0	5.5	1.75	8.0	2.0	4.0	φ 1.5	2.4	0.3
D3L	4.5	7.7	12.0	5.5	1.75	8.0	2.0	4.0	φ 1.5	3.2	0.3
D4	4.5	7.7	12.0	5.5	1.75	8.0	2.0	4.0	φ 1.5	4.2	0.3

- Dimension A and B are the measure of compartment's inside bottom.
- The (+) Polarity of the chip is placed on right side towards the unreeling direction.
- Dimension of the topcover tape Width of cover tape: 9.5±0.2 mm 5.5±0.2 mm (φ 180reel)

Reel dimension

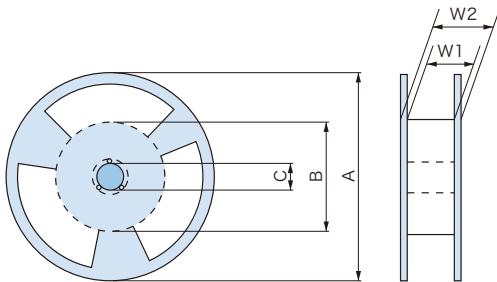

A	B	C	W1	W2
φ 330±2	φ 80±2	φ 13±0.2	13.5±0.5	17.5±1.0
φ 180 $_{-3}^0$	φ 60±2	φ 13±0.2	9±0.5	11.4±1.0

(unit:mm)

Minimum packing quantity and weight

Size code	Quantity(pcs./Reel, φ 180)	Typical weight(g)	Size code	Quantity(pcs./Reel, φ 330)	Typical weight(g)
B1	3000	200	D12	4500	1200
B1G	2500	200	D15	3000	1000
B1S	2500	200	D15E, D15S	4000	1000
B2	2000	200	D2E	3000	1000
B2S	2000	200	D2	3000	1000
			D3L	2500	1100
			D4	2000	1200

※Small order quantity (500 pcs/reel) is available with TPE, TPF and TQC series. Please contact our sales representative if you prefer it.

Dimension of packing case

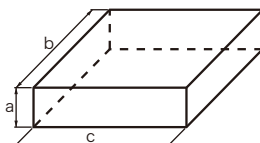

Reel size	φ 180	φ 330
a	90	120
b	240	360
c	240	360

(unit:mm)

Units per packing case

Size code	Pieces/case	Size code	Pieces/case
B1	15000	D12	22500
B1G	12500	D15	15000
B1S	12500	D15E, D15S	20000
B2	10000	D2E	15000
B2S	10000	D2	15000
		D3L	12500
		D4	10000

SP-Cap

Guidelines and Precautions
Mounting specifications
Packing specifications

Selection guide

Surface mount type

Catalog EOL models

POSCAP

Guidelines and Precautions
Mounting specifications
Packing specifications

Line-up
Series, system diagram
Size list
Products list

Surface mount type

- TPG
- TPS
- TPSF
- TQS
- TPE
- TPF
- TQC
- TA
- TV
- TH
- TPB
- TC
- TDC
- TPC

Catalog Deletion models

Catalog EOL models

OS-CON

Guidelines and Precautions
Mounting specifications
Packing specifications

Selection guide

Surface mount type

Radial lead type

Catalog EOL models

Hybrid

Guidelines and Precautions
Mounting specifications
Packing specifications

Selection guide

Surface mount type

Radial lead type

Line-up

SP-Cap

Guidelines and Precautions
Mounting specifications
Packing specifications

Selection guide

Surface mount type

Catalog EOL models

POSCAP

Guidelines and Precautions
Mounting specifications
Packing specifications

Line-up

Series system diagram
Size list

Products list

- TPG
- TPS
- TPSF
- TQS
- TPE
- TPF
- TQC
- TA
- TV
- TH
- TPB
- TC
- TDC
- TPC

Surface mount type

Catalog Deletion models

Catalog EOL models

OS-CON

Guidelines and Precautions
Mounting specifications
Packing specifications

Selection guide

Surface mount type

Radial lead type

Catalog EOL models

Hybrid

Guidelines and Precautions
Mounting specifications
Packing specifications

Selection guide

Surface mount type

Radial lead type

Series	Page	Features	Small size/Low profile	Large capacitance	Low ESR	For automotive	High voltage	Guaranteed at 25°C	Category temperature range(°C)	Rated voltage (V)	ESR(mΩ)	Capacitance (μF)	Size code	Size (mm)		
														L	W	H
TPG	51	Small size Low profile Large capacitance	●	●					-55 to 105	10 to 12.5	35 to 70	33 to 47	B1G	3.5	2.8	1.1
TPS	52	Small size / Low profile Large capacitance Face down terminal	●	●					-55 to 105	2.5 to 6.3	30 to 35	150 to 330	B1S	3.5	2.8	1.1
TPSF	53	Low ESR / Small size Large capacitance Face down terminal	●	●	●				-55 to 105	2.0 to 2.5	6 to 9	270	B2S	3.5	2.8	1.9
TPE	55 to 58	Low ESR			●				-55 to 105	2.0 to 10	9 to 70	47 to 470	B2	3.5	2.8	1.9
									-55 to 105	6.3	35	470	D15E	7.3	4.3	1.4
									-55 to 105	2.5 to 10	7 to 45	68 to 470	D2E	7.3	4.3	1.8
									-55 to 105	2.5 to 10	9 to 40	150 to 680	D3L	7.3	4.3	2.8
									-55 to 105	2.5 to 10	10 to 40	330 to 1500	D4	7.3	4.3	3.8
TPF	59 to 60	Low ESR Large capacitance			●	●			-55 to 105	2.0	6	220 to 330	D2E	7.3	4.3	1.8
									-55 to 105	2.5 to 10	5 to 25	150 to 680	D3L	7.3	4.3	2.8
									-55 to 105	2.5 to 6.3	5 to 35	470 to 1000	D4	7.3	4.3	3.8
TQS	54	High voltage					●	-55 to 105	35	100	47	D15S	7.3	4.3	1.4	
TQC	61 to 62	High voltage					●		-55 to 105	16 to 35	90 to 400	3.9 to 47	B2	3.5	2.8	1.9
									-55 to 105	16	40	33	D12	7.3	4.3	1.15
									-55 to 105	16 to 25	55 to 70	22 to 47	D15	7.3	4.3	1.4
									-55 to 105	16 to 35	40 to 150	10 to 150	D2	7.3	4.3	1.9
									-55 to 105	16 to 25	50 to 70	68 to 220	D3L	7.3	4.3	2.8

Series	Page	Features	Small size/Low profile	Large capacitance	Low ESR	For automotive	High voltage	Guaranteed at 125 °C	Category temperature range(°C)	Rated voltage (V)	ESR(mΩ)	Capacitance (μF)	Size code	Size (mm)		
														L	W	H
TA	63	High reliability				●			-55 to 105	4.0 to 10	70	47 to 100	B2	3.5	2.8	1.9
									-55 to 105	2.5 to 10	9 to 25	68 to 470	D2E	7.3	4.3	1.8
									-55 to 105	2.5 to 10	15 to 25	150 to 680	D3L	7.3	4.3	2.8
TV	64	High reliability Guaranteed at 125 °C				●	●		-55 to 125	6.3 to 10	25	68 to 150	D2E	7.3	4.3	1.8
									-55 to 125	10	25	150	D3L	7.3	4.3	2.8
TH	65	Guaranteed at 125 °C					●		-55 to 125	2.5 to 6.3	15 to 25	150 to 330	D2E	7.3	4.3	1.8
									-55 to 125	2.5 to 10	40 to 45	68 to 220	D2	7.3	4.3	1.9
									-55 to 125	4.0 to 6.3	40	220 to 330	D3L	7.3	4.3	2.8
									-55 to 125	6.3 to 10	35 to 40	220 to 470	D4	7.3	4.3	3.8
TPB	66	Standard							-55 to 105	4.0 to 10	70	33 to 68	B2	3.5	2.8	1.9
									-55 to 105	4.0 to 10	40 to 55	150 to 330	D3L	7.3	4.3	2.8
									-55 to 105	6.3 to 10	35 to 40	220 to 470	D4	7.3	4.3	3.8
TC	67 to 68	Guaranteed at 125 °C					●		-55 to 125	4.0 to 6.3	15 to 25	100 to 330	D2E	7.3	4.3	1.8
									-55 to 125	2.5 to 10	5 to 25	150 to 680	D3L	7.3	4.3	2.8
									-55 to 125	2.5 to 10	5 to 25	330 to 1000	D4	7.3	4.3	3.8
TDC	69	High voltage Guaranteed at 125 °C				●	●		-55 to 125	1.6 to 25	90 to 100	15 to 33	B2	3.5	2.8	1.9
									-55 to 125	16	50	100	D2	7.3	4.3	1.9
									-55 to 125	16 to 25	50 to 70	68 to 150	D3L	7.3	4.3	2.8
TPC	70	Low profile	●						-55 to 105	6.3 to 12.5	5 to 80	10 to 47	B1	3.5	2.8	1.1
									-55 to 105	6.3 to 10	40 to 100	68 to 330	D2	7.3	4.3	1.9

SP-Cap

Guidelines and Precautions
Mounting specifications
Packing specifications

Selection guide

Surface mount type

Catalog EOL models

POSCAP

Guidelines and Precautions
Mounting specifications
Packing specifications

Line-up
Series system diagram
Size list
Products list

TPG
TPS
TPSF
TQS
TPE
TPF
TQC
TA
TV
TH
TPB
TC
TDC
TPC

Surface mount type

Catalog Deletion models

Catalog EOL models

OS-CON

Guidelines and Precautions
Mounting specifications
Packing specifications

Selection guide

Surface mount type

Radial lead type

Catalog EOL models

Hybrid

Guidelines and Precautions
Mounting specifications
Packing specifications

Selection guide

Surface mount type

Radial lead type

Series system diagram / Size list

SP-Cap

Guidelines and Precautions
Mounting specifications
Packing specifications

Selection guide

Surface mount type

Catalog EOL models

POSCAP

Guidelines and Precautions
Mounting specifications
Packing specifications

Line-up

Series system diagram
Size list
Selection guide

Products list

TPG

TPS

TPSF

TQS

TPE

TPF

TQC

TA

TV

TH

TPB

TC

TDC

TPC

Surface mount type

Catalog Deletion models

Catalog EOL models

OS-CON

Guidelines and Precautions
Mounting specifications
Packing specifications

Selection guide

Surface mount type

Radial lead type

Catalog EOL models

Hybrid

Guidelines and Precautions
Mounting specifications
Packing specifications

Selection guide

Surface mount type

Radial lead type

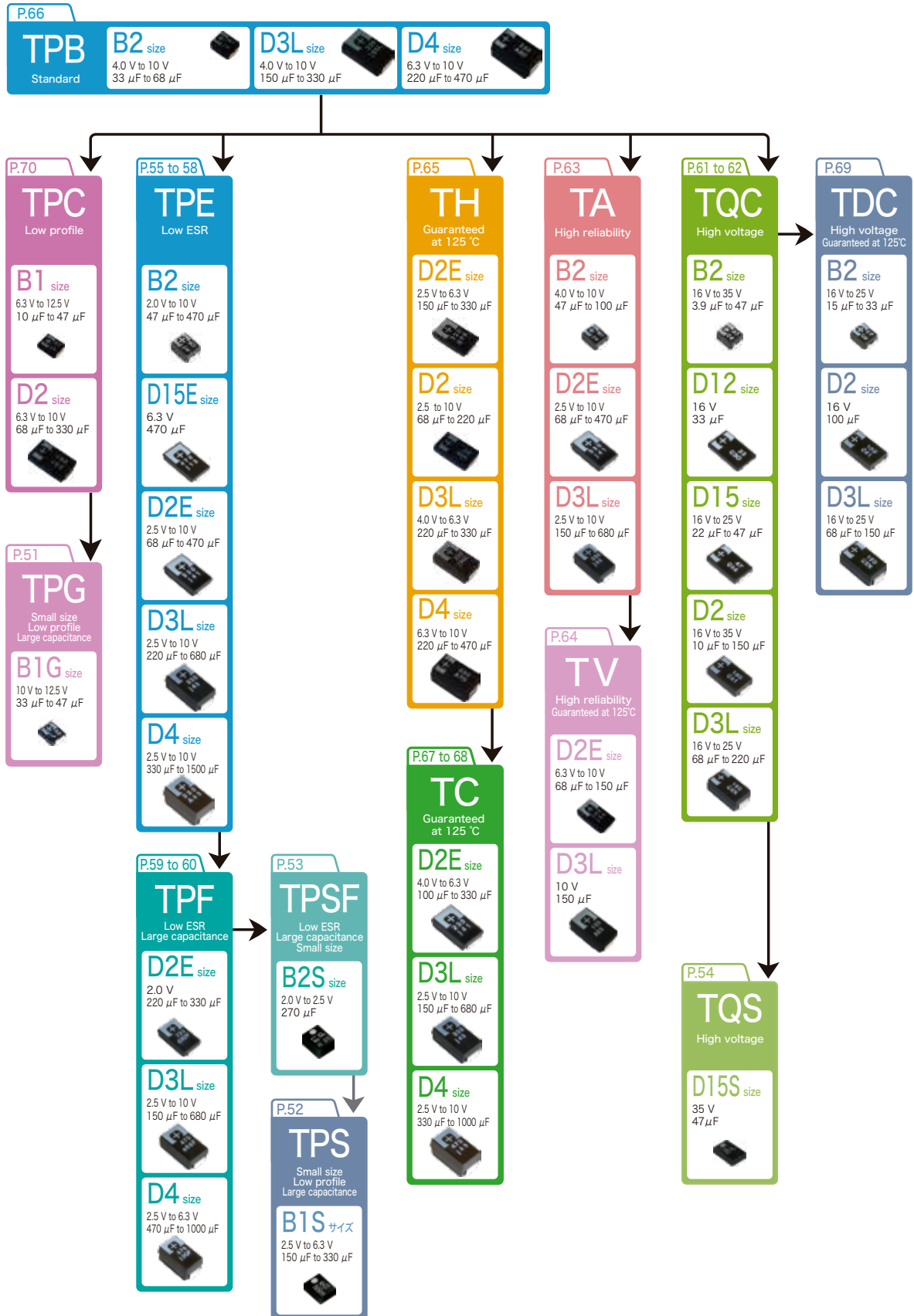

Case size (Unit:mm)

	B1	B1G	B1S	B2	B2S	D12	D15	D15E	D15S	D2E	D2	D3L	D4
L	3.5	3.5	3.5	3.5	3.5	7.3	7.3	7.3	7.3	7.3	7.3	7.3	7.3
W	2.8	2.8	2.8	2.8	2.8	4.3	4.3	4.3	4.3	4.3	4.3	4.3	4.3
H	1.1	1.1	1.1	1.9	1.9	1.15	1.4	1.4	1.4	1.8	1.9	2.8	3.8

The size of each photo is nearly to full scale.

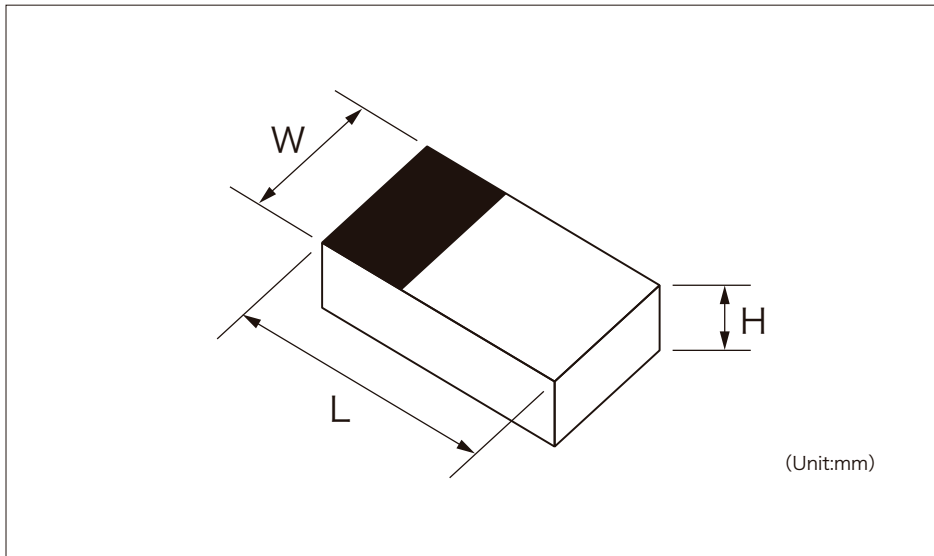

B1 size	B1G size	B1S size	B2 size	B2S size
3.5x2.8x1.1	3.5x2.8x1.1	3.5x2.8x1.1	3.5x2.8x1.9	3.5x2.8x1.9
P.70	P.51	P.52	P.55 to 58	P.53
TPC	TPG	TPS	TPE	TPSF
6.3 V to 12.5 V 10 μF to 47 μF	2.5 V to 12.5 V 33 μF to 220 μF	2.5 V to 6.3 V 150 μF to 330 μF	2.0 V to 10 V 47 μF to 470 μF	2.0 V to 2.5 V 270 μF
			P.61 to 62	
			TQC	
			16 V to 35 V 3.9 μF to 33 μF	
			P.66	
			TPB	
			4.0 V to 10 V 33 μF to 68 μF	

LxWxH(Unit:mm)

D12 size	D15 size	D15E size	D15S size	D2E size	D2 size	D3L size	D4 size
7.3x4.3x1.15	7.3x4.3x1.4	7.3x4.3x1.4	7.3x4.3x1.4	7.3x4.3x1.8	7.3x4.3x1.9	7.3x4.3x2.8	7.3x4.3x3.8
P.61 to 62	P.61 to 62	P.55 to 57	P.54	P.55 to 58	P.6 to 68	P.61 to 62	P.55 to 58
TQC	TQC	TPE	TQS	TPE	TC	TQC	TPE
16 V 33 μF	16 V to 25 V 22 μF to 47 μF	6.3 V 470 μF	35 V 47 μF	2.5 V to 10 V 68 μF to 470 μF	4.0 V to 6.3 V 100 μF to 330 μF	16 V to 35 V 10 μF to 150 μF	2.5 V to 10 V 330 μF to 1500 μF
				P.59 to 60		P.65	P.59 to 60
				TPF		TH	TPF
				2.0 V 220 μF to 330 μF		2.5 V to 10 V 68 μF to 220 μF	2.5 V to 10 V 470 μF to 1000 μF
				P.63		P.69	P.65
				TA		TDC	TH
				2.5 V to 10 V 68 μF to 470 μF		16 V 100 μF	6.3 V to 10 V 220 μF to 470 μF
				P.64		P.70	P.66
				TV		TPC	TPB
				6.3 V to 10 V 68 μF to 150 μF		6.3 V to 10 V 68 μF to 330 μF	6.3 V to 10 V 220 μF to 470 μF
				P.65		P.64	P.67 to 68
				TH		TV	TC
				2.5 V to 6.3 V 150 μF to 330 μF		10 V 150 μF	2.5 V to 10 V 330 μF to 1000 μF

The size of each photo is nearly to full scale.

SP-Cap

Guidelines and Precautions
Mounting specifications
Packing specifications

Selection guide

Surface mount type

Catalog EOL models

POSCAP

Guidelines and Precautions
Mounting specifications
Packing specifications

Line-up
Series system diagram
Size list

Products list

- TPG
- TPS
- TPSF
- TQS
- TPE
- TPF
- TQC
- TA
- TV
- TH
- TPB
- TC
- TDC
- TPC

Catalog Deletion models

Catalog EOL models

OS-CON

Guidelines and Precautions
Mounting specifications
Packing specifications

Selection guide

Surface mount type

Radial lead type

Catalog EOL models

Hybrid

Guidelines and Precautions
Mounting specifications
Packing specifications

Selection guide

Surface mount type

Radial lead type

Products list

SP-Cap

Size·ESR Matrix list

Size code (ESR mΩ)

V	Series	μF	3.9	4.7	5.6	6.8	8.2	10	15	22	33	47	68
2.0	TPSF												
	TPE												
	TPF												
2.5	TPS												
	TPSF												
	TPE												
	TPF												
4.0	TA												
	TH												
	TC												
	TPS												
6.3	TPE												
	TPF												
	TA											B2(70)	B2(70)
	TV										B2(70)		B2(70)
	TPB												
	TPC											B1(70,55)	
	TH												
	TC												
	TPG												B1G(70)
	TPE												
10	TPC												
	TPG												B1G(70)
	TPE											B2(35)	D2E(40,25)
	TPF												
	TA											B2(70)	D2E(25)
	TV												D2E(25)
	TPB											B2(70)	B2(70)
	TPC												D2(100,60,45)
12.5	TH												D2(45)
	TC												
16	TPG												B1G(70)
	TPC												
	TQC											B1(80)	B1(80)
20	TQC											B2(100)	B2(90)
	TDC											B2(90)	B2(90)
	TQC											B2(90)	B2(90)
25	TQC											B2(90)	B2(90)
	TDC											D2(90)	D2(90)
	TQC											D2(60)	D2(60)
35	TQC											D2(60)	D2(60)
	TDC											D2(90)	D2(90)
	TQC											D2(90,45)	D2(60,45)
35	TQC											D2(100)	D2(100)
	TQS											D2(150)	D2(150)
35	TQC											D2(200,150)	D2(150)
	TQS											D2(120)	D2(120)
35	TQC											D2(400)	D2(400)
	TQS											D15S(100)	D15S(100)

Case size

(unit : mm)

	B1	B1G	B1S	B2	B2S	D12	D15	D15E	D15S	D2E	D2	D3L	D4
L	3.5	3.5	3.5	3.5	3.5	7.3	7.3	7.3	7.3	7.3	7.3	7.3	7.3
W	2.8	2.8	2.8	2.8	2.8	4.3	4.3	4.3	4.3	4.3	4.3	4.3	4.3
H	1.1	1.1	1.1	1.9	1.9	1.15	1.4	1.4	1.4	1.8	1.9	2.8	3.8

SP-Cap

Guidelines and Precautions
Mounting specifications
Packing specifications

Selection guide

Surface mount type

Catalog EOL models

POSCAP

Guidelines and Precautions
Mounting specifications
Packing specifications

Selection guide
Line-up
Series system diagram
Size list
Products list

Surface mount type

Catalog Deletion models
Catalog EOL models

OS-CON

Guidelines and Precautions
Mounting specifications
Packing specifications

Selection guide

Surface mount type

Radial lead type

Catalog EOL models

Hybrid

Guidelines and Precautions
Mounting specifications
Packing specifications

Selection guide

Surface mount type

Radial lead type

V	Series	100	120	150	220	270	330	470	680	1000	1500
2.0	TPSF					B2S(9 / 6)					
	TPE							B2(15,11)			
	TPF				D2E(6)		D2E(6)				
2.5	TPS				B1S(30)		B1S(30)				
	TPSF					B2S(6)					
	TPE				B2(35,30,25,21,15) D2E(25,18,15,9)		B2(35,18,15,9) D2E(25,18,15,12,9,7)	D2E(18,15,12,9,7)	D3L(40,15,12)	D4(15)	D4(15,12)
	TPF						D3L(7) D4(5)	D3L(10,7,6) D4(25,5)	D3L(10,9,7,6)	D4(6,5)	
	TA				D2E(25,15,9)		D2E(25,18,15)	D2E(25,15)	D3L(25,15)		
	TH				D2(45)		D2E(25,18,15)				
	TC						B2(9)		D3L(15,12,10,7,6,5) D4(5)	D4(15,6,5)	
	TPS				B1S(30,35)						
4.0	TPE	B2(70,40,35)		B2(35) D2E(18)	B2(70,45,35) D2E(45,25,18,15)		D2E(40,25,18)	D3L(40,25,18,15,12)			
	TPF						D3L(15,12,9)	D3L(10)	D4(35,15,10)		
	TA	B2(70)			D2E(25,18)			D3L(25,18)			
	TPB						D3L(40)				
	TH				D2E(25,18,15)		D3L(40)				
	TC				D2E(18) D2E(25,18,15)		D2E(25,18) D3L(12)	D3L(25,18,15,12,10)	D4(10)		
	TPS				B1S(30)						
6.3	TPE	B2(70,45,40,35,25) D2E(45,25,18)	B2(35)	B2(35,25)	B2(70,45,35,25) D2E(40,25,18)		D2E(25)	D15E(35)	D4(25,18)		
	TPF				D3L(18)		D4(10)				
	TA				D3L(25) D2E(25)	D3L(25,15,12,9,6,5) D2E(25,18)	D3L(10,9) D3L(25)	D4(15,10)			
	TV				D2E(25)						
	TPB					D3L(50,40)	D3L(45,40) D4(40)	D4(35)			
	TPC	D2(45)			D2(40)		D2(40)				
	TH				D2E(25,18) D2(40)	D3L(40)		D4(40) D4(35)			
	TC	D2E(25,18)			D2E(25,18,15) D3L(12,9,5)	D2E(25,18)	D3L(25,18,15,9)	D4(25,18,10) D4(25,18)			
	TPG										
	8.0	TPE	B2(35)								
TPC					D2(40)						
10	TPG										
	TPE				D3L(25)	D3L(25,18)		D4(25)			
	TPF				D3L(15)						
	TA				D3L(25)	D3L(25)					
	TV				D3L(25)						
	TPB				D3L(55,40)	D3L(40)		D4(40,35)			
	TPC	D2(55,50,45)									
	TH					D4(40)		D4(35)			
12.5	TPG										
	TPC				D3L(15)	D3L(25,18)		D4(25)			
16	TQC	D2(50)			D3L(50)	D3L(50)					
	TDC	D2(50)			D3L(50)						
20	TQC	D3L(55)									
	TDC	D2(100)									
25	TQC	D3L(55)									
	TDC	D3L(60)									
35	TQC										
	TQS										



Small size, Low profile(L3.5xW2.8xH1.1 mm)

RoHS compliance, Halogen free

SP-Cap

Guidelines and Precautions
Mounting specifications
Packing specifications

Selection guide

Surface mount type

Catalog EOL models

POSCAP

Guidelines and Precautions
Mounting specifications
Packing specifications

Line-up
Series system diagram
Size list
Selection guide
Products list

TPG

TPS

TPSF

TQS

TPE

TPF

TQC

TA

TV

TH

TPB

TC

TDC

TPC

Surface mount type

Catalog Deletion models

Catalog EOL models

OS-CON

Guidelines and Precautions
Mounting specifications
Packing specifications

Selection guide

Surface mount type

Radial lead type

Catalog EOL models

Hybrid

Guidelines and Precautions
Mounting specifications
Packing specifications

Selection guide

Surface mount type

Radial lead type

Specifications

Items	Specifications	
Size code	B1G	
Category temperature range	-55 °C to +105 °C	
Rated voltage range	10.0 V, 12.5 V	
Category voltage range	8 V, 10.0 V	
Rated capacitance range	33 μ F, 47 μ F	
Capacitance tolerance	\pm 20 % (120 Hz/+20 °C)	
Leakage current	Please see the attached characteristics list	
Dissipation factor(tan δ)	Please see the attached characteristics list	
Surge voltage(V)	Rated voltage x1.15	
Endurance	+85 °C, 1000 h, rated voltage applied	
	Capacitance change	Within \pm 20 % of the initial value
	tan δ	\leq 1.5 times of the initial limit
Damp heat(Steady state)	DC leakage current	Within the initial limit
	+60 °C, 90 % to 95 % RH, 500 h, No-applied voltage	
	Capacitance change	Within+40 %, -20 % of the initial value
	tan δ	\leq 1.5 times of the initial limit
DC leakage current	\leq 3 times of the initial limit	

Marking and Dimensions

(unit : mm)

Size code	L +0.3/-0.1	W +0.3/-0.1	H \pm 0.1	S \pm 0.2	W1 \pm 0.1
B1G	3.5	2.8	1.1	0.8	2.2

R. voltage (V)	10.0	12.5
Code	A	B

R. cap. (μ F)	33	47
Code	N7	S7

Characteristics list

Series	Rated voltage (V)	Rated temp. (°C)	Category voltage (V)	Category temp. (°C)	Rated capacitance (μ F)	Case size(mm)			Size code	Specifications				Standard		Floor life	
						L	W	H		Ripple current ※1 (mA rms)	ESR ※2 (m Ω max.)	tan δ ※3	LC ※4 (μ A)	Part number ※5	Min. Packaging Qty (pcs)	Reflow temp. \leq 260°C	Reflow temp. \leq 250°C
TPG	10	85	8	105	47	3.5	2.8	1.1	B1G	1000	70	0.10	47.0	10TPG47M	2500	3	3
	12.5	85	10	105	33	3.5	2.8	1.1		1000	70	0.10	41.3	12TPG33M	2500		

※1: Ripple current (100 kHz/ +45 °C)

※2: ESR (100 kHz/+20 °C)

※3: tan δ (120 Hz/+20 °C)

※4: After 5 minutes

※5: Compatible products available

◆Please refer to each page in this catalog for "Reflow conditions" and "Taping specifications".

◆Please refer to page 42 for floor life level.



105 °C 2000 h

Small size, Low profile(L 3.5 × W 2.8 × H 1.2 mm max.)

RoHS compliance, Halogen free

Specifications

Items	Specifications	
Size code	B1S	
Category temperature range	-55 °C to +105 °C	
Rated voltage range	2.5 V to 6.3 V	
Category voltage range	2.5 V to 6.3 V	
Rated capacitance range	150 μF to 330 μF	
Capacitance tolerance	±20 % (120 Hz/+20 °C)	
Leakage current	Please see the attached characteristics list	
Dissipation factor(tan δ)	Please see the attached characteristics list	
Surge voltage(V)	Rated voltage × 1.15	
Endurance	+105 °C, 1000 h rated voltage applied	
	Capacitance change	Within ±20 % of the initial value
	tan δ	≤ 1.5 times of the initial limit
	DC leakage current	Within the initial limit
Damp heat(Steady state)	+60 °C, 90 % to 95 % RH, 500 h, No-applied voltage	
	Capacitance change	Within +40 %, -20 % of the initial value
	tan δ	≤ 1.5 times of the initial limit
	DC leakage current	≤ 3 times of the initial limit

Marking and Dimensions

R. voltage (V)	2.5	4.0	6.3	R. cap.(μF)	150	220	330	(unit : mm)					
Code	e	g	j	Code	E8	J8	N8	Size code	L ±0.2	W ±0.2	H ±0.1	S ±0.3	W1 ±0.1
								B1S	3.5	2.8	1.1	0.8	2.2

Characteristics list

Series	Rated voltage (V)	Rated temp. (°C)	Category voltage (V)	Category temp. (°C)	Rated capacitance (μF)	Case size (mm)			Size code	Specifications				Standard		Floor life	
						L	W	H		Ripple current ※1 (mA rms)	ESR ※2 (mΩ max.)	tan δ ※3	LC ※4 (μA)	Part number ※5	Min. Packaging Qty (pcs)	Reflow temp. ≤260°C	Reflow temp. ≤250°C
TPS	2.5	105	2.5	105	220	3.5	2.8	1.1	B1S	1400	30	0.10	55.0	ETPS220MUD	2500	3	3
		105	2.5	105	330	3.5	2.8	1.1		1400	30	0.10	82.5	ETPS330MUD	2500		
	4.0	105	4.0	105	220	3.5	2.8	1.1		1400	30	0.10	88.0	4TPS220MUD	2500		
		105	6.3	105	150	3.5	2.8	1.1		1400	30	0.10	94.5	6TPS150MUD	2500		
	6.3	105	6.3	105	150	3.5	2.8	1.1		1250	35	0.10	94.5	6TPS150MZD	2500		

※1: Ripple current (100 kHz/ +45 °C)

※2: ESR (100 kHz/+20 °C)

※3: tan δ (120 Hz/+20 °C)

※4: After 5 minutes

◆Please refer to each page in this catalog for "Reflow conditions" and "Taping specifications".

◆Please refer to page 42 for floor life level.

SP-Cap

Guidelines and Precautions
Mounting specifications
Packing specifications

Selection guide

Surface mount type

Catalog EOL models

POSCAP

Guidelines and Precautions
Mounting specifications
Packing specifications

Line-up
Series system diagram
Size list
Products list

- TPG
- TPS**
- TPSF
- TQS
- TPE
- TPF
- TQC
- TA
- TV
- TH
- TPB
- TC
- TDC
- TPC

Catalog Deletion models

Catalog EOL models

OS-CON

Guidelines and Precautions
Mounting specifications
Packing specifications

Selection guide

Surface mount type

Radial lead type

Catalog EOL models

Hybrid

Guidelines and Precautions
Mounting specifications
Packing specifications

Selection guide

Surface mount type

Radial lead type



Super low ESR (6 mΩ max.)

Super low ESL (0.7 nH)

Face down terminal type

RoHS compliance, Halogen free

SP-Cap

Guidelines and Precautions
Mounting specifications
Packing specifications

Selection guide

Surface mount type

Catalog EOL models

POSCAP

Guidelines and Precautions
Mounting specifications
Packing specifications

Line-up
Series system diagram
Size list

Products list

TPG

TPS

TPSF

TQS

TPE

TPF

TQC

TA

TV

TH

TPB

TC

TDC

TPC

Catalog Deletion models

Catalog EOL models

OS-CON

Guidelines and Precautions
Mounting specifications
Packing specifications

Selection guide

Surface mount type

Radial lead type

Catalog EOL models

Hybrid

Guidelines and Precautions
Mounting specifications
Packing specifications

Selection guide

Surface mount type

Radial lead type

Specifications

Items	Specifications	
Size code	B2S	
Category temperature range	-55 °C to +105 °C	
Rated voltage range	2 V, 2.5 V	
Category voltage range	2 V, 2.5 V	
Rated capacitance range	270 μF	
Capacitance tolerance	±20 % (120 Hz/+20 °C)	
Leakage current	Please see the attached characteristics list	
Dissipation factor(tanδ)	Please see the attached characteristics list	
Surge voltage(V)	Rated voltage x1.15	
Endurance	+105 °C, 1000 h rated voltage applied	
	Capacitance change	Within±20 % of the initial value
	tanδ	≤ 1.5 times of the initial limit
Damp heat(Steady state)	DC leakage current	Within the initial limit
	+60 °C, 90 % to 95 % RH, 500 h, No-applied voltage	
	Capacitance change	Within+40 %, -20 % of the initial value
	tanδ	≤ 1.5 times of the initial limit
DC leakage current	≤ 3 times of the initial limit	

Marking and Dimensions

(unit : mm)

Size code	L ±0.2	W ±0.2	H ±0.1	S ±0.3	W1 ±0.1
B2S	3.5	2.8	1.9	0.8	2.2

R. voltage (V)	2.0	2.5	R. cap.(μF)	270
Code	d	e	Code	L8

Characteristics list

Series	Rated voltage (V)	Rated temp. (°C)	Category voltage (V)	Category temp. (°C)	Rated capacitance (μF)	Case size (mm)			Size code	Specifications				Standard		Floor life	
						L	W	H		Ripple current ※1 (mA rms)	ESR ※2 (mΩ max.)	tan δ ※3	LC ※4 (μA)	Part number	Min. Package Qty (pcs)	Reflow temp. ≤260°C	Reflow temp. ≤250°C
TPSF	2	105	2	105	270	3.5	2.8	1.9	B2S	3200	6/500kHz	0.08	108.0	2TPSF270M6E	2000	5	5
		105	2	105		3.5	2.8	1.9		2400	9/300kHz	0.08	108.0	2TPSF270M9G	2000	3	3
	2.5	105	2.5	105		3.5	2.8	1.9		3200	6/500kHz	0.08	135.0	ETPSF270M6E	2000	3	3

※1: Ripple current (100 kHz/ +45 °C)

※2: ESR (100 kHz/+20 °C)

※3: tan δ (120 Hz/+20 °C)

※4: After 5 minutes

◆Please refer to each page in this catalog for "Reflow conditions" and "Taping specifications".

◆Please refer to page 42 for floor life level.



High voltage (35 V max.)

RoHS compliance, Halogen free

Specifications

Items	Specifications	
Size code	D15S	
Category temperature range	-55 °C to +105 °C	
Rated voltage range	35 V	
Category voltage range	35 V	
Rated capacitance range	47 μF	
Capacitance tolerance	±20 % (120 Hz/+20 °C)	
Leakage current	Please see the attached characteristics list	
Dissipation factor (tan δ)	Please see the attached characteristics list	
Surge voltage (V)	Rated voltage x 1.15	
Endurance	+105 °C, 2000 h rated voltage applied	
	Capacitance change	Within ±20 % of the initial value
	tan δ	≤ 1.5 times of the initial limit
	DC leakage current	Within the initial limit
Damp heat (Steady state)	+60 °C, 90 % to 95 % RH, 500 h, No-applied voltage	
	Capacitance change	Within +40 %, -20 % of the initial value
	tan δ	≤ 1.5 times of the initial limit
	DC leakage current	≤ 3 times of the initial limit

Marking and Dimensions

(unit : mm)

Size code	L +0.3	W +0.2	H +0.1	S1 +0.2	S2 +0.2	W1 +0.1
D15S	7.3	4.3	1.4	1.1	1.4 ※1	2.4

※1: - side

R. voltage (V)	35
Code	V

Characteristics list

Series	Rated voltage (V)	Rated temp. (°C)	Category voltage (V)	Category temp. (°C)	Rated capacitance (μF)	Case size (mm)			Size code	Specifications				Standard		Floor life	
						L	W	H		Ripple current ※1 (mA rms)	ESR ※2 (mΩ max.)	tan δ ※3	LC ※4 (μA)	Part number	Min. Packaging Qty (pcs)	Reflow temp. ≤260°C	Reflow temp. ≤250°C
TQS	35	105	35	105	47	7.3	4.3	1.4	D15S	1200	100	0.10	164.5	35TQS47MEU	4000	3	3

※1: Ripple current (100 kHz/ +105 °C)

※2: ESR (100 kHz/+20 °C)

※3: tan δ (120 Hz/+20 °C)

※4: After 5 minutes

◆Please refer to each page in this catalog for "Reflow conditions" and "Taping specifications".

◆Please refer to page 42 for floor life level.

SP-Cap

Guidelines and Precautions
Mounting specifications
Packing specifications

Selection guide

Surface mount type

Catalog EOL models

POSCAP

Guidelines and Precautions
Mounting specifications
Packing specifications

Selection guide
Line-up
Series system diagram
Size list
Products list

TPG
TPS
TPSF
TQS
TPE
TPF
TQC
TA
TV
TH
TPB
TC
TDC
TPC

Catalog Deletion models

Catalog EOL models

OS-CON

Guidelines and Precautions
Mounting specifications
Packing specifications

Selection guide

Surface mount type

Radial lead type

Catalog EOL models

Hybrid

Guidelines and Precautions
Mounting specifications
Packing specifications

Selection guide

Surface mount type

Radial lead type



Small size (L3.5xW2.8xH1.9 mm)

Low ESR (15 mΩ)

RoHS compliance, Halogen free

SP-Cap

Guidelines and Precautions
Mounting specifications
Packing specifications

Selection guide

Surface mount type

Catalog EOL models

POSCAP

Guidelines and Precautions
Mounting specifications
Packing specifications

Line-up
Series system diagram
Size list
Selection guide

Products list

- TPG
- TPS
- TPSF
- TQS
- TPE**
- TPF
- TQC
- TA
- TV
- TH
- TPB
- TC
- TDC
- TPC

Surface mount type

Catalog Deletion models

Catalog EOL models

OS-CON

Guidelines and Precautions
Mounting specifications
Packing specifications

Selection guide

Surface mount type

Radial lead type

Catalog EOL models

Hybrid

Guidelines and Precautions
Mounting specifications
Packing specifications

Selection guide

Surface mount type

Radial lead type

Specifications

Items	Specifications	
Size code	B2	
Category temperature range	-55 °C to +105 °C	
Rated voltage range	2 V to 10 V	
Category voltage range	1.8 V to 8 V	
Rated capacitance range	47 μF to 470 μF	
Capacitance tolerance	±20 % (120 Hz/+20 °C)	
Leakage current	Please see the attached characteristics list	
Dissipation factor (tanδ)	Please see the attached characteristics list	
Surge voltage (V)	Rated voltage x 1.15	
Endurance	+105 °C, 1000 h rated voltage applied ※Rated temp, 85 °C Products: 85 °C, 1000 h, rated voltage applied	
	Capacitance change	Within ±20 % of the initial value
	tanδ	≤ 1.5 times of the initial limit
	DC leakage current	Within the initial limit
Damp heat (Steady state)	+60 °C, 90 % to 95 % RH, 500 h, No-applied voltage	
	Capacitance change	Within +50 %, -20 % (2R5TPE220MAZB (MAPB,MAFB), 2R5TPE330MAZB, 2TPE330MAFB (MADGB), 2TPE470MAJGB (MAFB), 2TPE330MFB, ETPE330MAFB (MA9GB))
	tanδ	Within +40 %, -20 % of the initial value (Except for above model)
	DC leakage current	≤ 3 times of the initial limit

Marking and Dimensions

(unit : mm)

Size code	L ±0.2	W ±0.2	H ±0.1	S ±0.2	W1 ±0.1
B2	3.5	2.8	1.9	0.8	2.2

R. voltage (V)	2.0	2.5	4.0	6.3	8.0	10.0
Code	d	e	g	j	k	A

R. cap. (μF)	47	100	120	150	220	330	470
Code	S7	A8	C8	E8	J8	N8	S8

Characteristics list

Series	Rated voltage (V)	Rated temp. (°C)	Category voltage (V)	Category temp. (°C)	Rated capacitance (μF)	Case size (mm)			Size code	Specifications				Standard		Floor life			
						L	W	H		Ripple current ※1 (mA rms)	ESR ※2 (mΩ max.)	tan δ ※3	LC ※4 (μA)	Part number	Min. Packaging Qty (pcs)	Reflow temp. ≤260°C	Reflow temp. ≤250°C		
TPE	2	85	1.8	105	470	3.5	2.8	1.9	B2	2300	15	0.10	188.0	2TPE470MAFB	2000	3	3		
		85	1.8	105		3.5	2.8	1.9		2300	11/300 kHz	0.08	188.0	2TPE470MAJGB	2000				
	2.5	85	2	105	220	3.5	2.8	1.9		2000	15	0.08	110.0	2R5TPE220MAFB	2000				
		105	2.5	105		3.5	2.8	1.9		1800	15/300 kHz	0.08	110.0	2R5TPE220MFGB	2000				
		105	2.5	105		3.5	2.8	1.9		1700	21	0.08	55.0	2R5TPE220MLB	2000				
		85	2	105		3.5	2.8	1.9		1600	25	0.08	55.0	2R5TPE220MAPB	2000				
		105	2.5	105		3.5	2.8	1.9		1400	35	0.08	55.0	2R5TPE220MZB	2000				
		85	2	105		3.5	2.8	1.9		1400	35	0.08	55.0	2R5TPE220MAZB	2000				
		105	2.5	105		3.5	2.8	1.9		1400	30	0.08	55.0	2R5TPE220MUB	2000				
		85	2	105		3.5	2.8	1.9		1400	35	0.08	82.5	2R5TPE330MAZB	2000				
		85	2	105		3.5	2.8	1.9		3200	9/300 kHz	0.08	165.0	ETPE330MA9GB	2000				
		105	2.5	105		330	3.5	2.8		1.9	3200	9/300 kHz	0.08	165.0	ETPE330M9GB			2000	
	4	4	105	2.5	105	100	3.5	2.8		1.9	2700	15	0.08	165.0	ETPE330MFB			2000	
			105	2.5	105		3.5	2.8		1.9	2450	18	0.08	165.0	ETPE330MIB			2000	
			105	4	105		3.5	2.8		1.9	1400	35	0.08	40.0	4TPE100MZB			2000	
			105	4	105		3.5	2.8		1.9	950	70	0.08	40.0	4TPE100MBB			2000	
			105	4	105		3.5	2.8		1.9	1300	40	0.08	40.0	4TPE100MWB			2000	
			85	3.2	105		150	3.5		2.8	1.9	1400	35	0.08	60.0			4TPE150MAZB	2000
			85	3.2	105		220	3.5		2.8	1.9	1400	35	0.08	88.0			4TPE220MAZB	2000
			105	4	105			3.5		2.8	1.9	1350	35	0.10	88.0			4TPE220MZB	2000
			105	4	105			3.5		2.8	1.9	1150	45	0.10	88.0			4TPE220MVB	2000
			105	4	105			3.5		2.8	1.9	950	70	0.10	88.0			4TPE220MBB	2000
	6.3	6.3	105	4	105	100	3.5	2.8		1.9	1600	25	0.08	63.0	6TPE100MPB			2000	
			85	5	105		3.5	2.8		1.9	1400	35	0.08	63.0	6TPE100MAZB			2000	
			105	6.3	105		3.5	2.8		1.9	1400	35	0.08	63.0	6TPE100MZB			2000	
			105	6.3	105		3.5	2.8		1.9	950	70	0.08	63.0	6TPE100MBB			2000	
			105	6.3	105		3.5	2.8		1.9	1300	40	0.08	63.0	6TPE100MWB			2000	
			105	6.3	105		3.5	2.8		1.9	1200	45	0.08	63.0	6TPE100MVB			2000	
			85	5	105		120	3.5		2.8	1.9	1400	35	0.08	75.6			6TPE120MAZB	2000
			85	5	105		150	3.5		2.8	1.9	1600	25	0.08	94.5			6TPE150MAPB	2000
			85	5	105			3.5		2.8	1.9	1400	35	0.08	94.5			6TPE150MAZB	2000
			85	5	105		220	3.5		2.8	1.9	1400	35	0.10	138.6			6TPE220MAZB	2000
			85	5	105			3.5		2.8	1.9	1600	25	0.10	138.6			6TPE220MAPB	2000
			105	6.3	105			3.5		2.8	1.9	1150	45	0.10	138.6			6TPE220MVB	2000
			105	6.3	105			3.5		2.8	1.9	950	70	0.10	138.6			6TPE220MBB	2000
			105	6.3	105			3.5		2.8	1.9	1350	35	0.10	138.6			6TPE220MZB	2000
	105	6.3	105	3.5	2.8	1.9		1400		35	0.08	80.0	8TPE100MAZB	2000					
	8	85	6.3	105	100	3.5	2.8	1.9		1400	35	0.08	47.0	10TPE47MAZB	2000				
	10	85	8	105	47	3.5	2.8	1.9		1400	35	0.08	47.0	10TPE47MAZB	2000				

※1: Ripple current (100 kHz/ +45 °C)

※2: ESR (100 kHz/+20 °C)

※3: tanδ (120 Hz/+20 °C)

※4: After 5 minutes

◆Please refer to each page in this catalog for "Reflow conditions" and "Taping specifications".

◆Please refer to page 42 for floor life level.

※: Small order quantity (500 pcs/reel) is available with TPE series. Please contact our sales representative if you prefer it.

SP-Cap

Guidelines and Precautions
Mounting specifications
Packing specifications

Selection guide

Surface mount type

Catalog EOL models

POSCAP

Guidelines and Precautions
Mounting specifications
Packing specifications

Line-up
Series system diagram
Size list
Products list

TPG
TPS
TPSF
TQS
TPE
TPF
TQC
TA
TV
TH
TPB
TC
TDC
TPC

Catalog Deletion models

Catalog EOL models

OS-CON

Guidelines and Precautions
Mounting specifications
Packing specifications

Selection guide

Surface mount type

Radial lead type

Catalog EOL models

Hybrid

Guidelines and Precautions
Mounting specifications
Packing specifications

Selection guide

Surface mount type

Radial lead type



Low profile (Height 1.5 mm max.)

Low ESR (7 mΩ)

Large capacitance (1500 μF max.)

RoHS compliance, Halogen free

Specifications

Items	Specifications			
	D15E	D2E	D3L	D4
Size code	D15E	D2E	D3L	D4
Category temperature range	-55 °C to +105 °C			
Rated voltage range	6.3 V	2.5 V to 10 V		
Category voltage range	5 V	2.5 V to 10 V		
Rated capacitance range	470 μF	68 μF to 470 μF	220 μF to 680 μF	330 μF to 1500 μF
Capacitance tolerance	±20 % (120 Hz/+20 °C)			
Leakage current	Please see the attached characteristics list			
Dissipation factor (tanδ)	Please see the attached characteristics list			
Surge voltage (V)	Rated voltage x1.15			
Endurance	+105 °C, 2000 h, rated voltage applied ※Rated temp, 85 °C products: 85 °C, 1000 h, rated voltage applied (6TPE330MAP, 6TPE470MAZU: 85 °C, 2000 h)			
	Capacitance change	Within ±20 % of the initial value		
	tanδ	≤ 1.5 times of the initial limit		
	DC leakage current	Within the initial limit		
Damp heat (Steady state)	+60 °C, 90 % to 95 % RH, 500 h, No-applied voltage			
	Capacitance change	Within +50 %, -20 % (2R5TPE220M(I, F, 9), 2R5TPE330M(I, F, C, 9, 7), 2R5TPE470M(I, F, C, 9, 7), 2R5TPE1000MF, 2R5TPE1000M(F, C)) Within +40 %, -20 % of the initial value (Except for above model)		
	tanδ	≤ 1.5 times of the initial limit		
	DC leakage current	≤ 3 times of the initial limit		

Marking and Dimensions

Size code	L ±0.3	W ±0.2	H ±0.2 ※1	S ±0.2	W1 ±0.1
D15E	7.3	4.3	1.4	1.1	2.4
D2E	7.3	4.3	1.8	1.3	2.4
D3L	7.3	4.3	2.8	1.3	2.4
D4	7.3	4.3	3.8	1.3	2.4

※1 ±0.1 : D2E, D15E

R. voltage (V)	2.5	4.0	6.3	10.0
Code	e	g	j	A

Characteristics list (2.5V)

Series	Rated voltage (V)	Rated temp. (°C)	Category voltage (V)	Category temp. (°C)	Rated capacitance (μF)	Case size (mm)			Size code	Specifications				Standard		Floor life	
						L	W	H		Ripple current ※1 (mA rms)	ESR ※2 (mΩ max.)	tan δ ※3	LC ※4 (μA)	Part number	Min. Packaging Qty (pcs)	Reflow temp. ≤260°C	Reflow temp. ≤250°C
TPE	2.5	105	2.5	105	220	7.3	4.3	1.8	D2E	3900	9	0.10	55.0	2R5TPE220M9	3000	3	2a
						7.3	4.3	1.8		3100	15	0.10	55.0	2R5TPE220MF	3000		
						7.3	4.3	1.8		2800	18	0.10	55.0	2R5TPE220MI	3000		
						7.3	4.3	1.8		2400	25	0.10	55.0	2R5TPE220M	3000		
						7.3	4.3	1.8		4400	7	0.10	82.5	2R5TPE330M7	3000		
						7.3	4.3	1.8		3900	9	0.10	82.5	2R5TPE330M9	3000		
						7.3	4.3	1.8		3500	12	0.10	82.5	2R5TPE330MC	3000		
						7.3	4.3	1.8		3100	15	0.10	82.5	2R5TPE330MF	3000		
						7.3	4.3	1.8		2800	18	0.10	82.5	2R5TPE330MI	3000		
						7.3	4.3	1.8		2400	25	0.10	82.5	2R5TPE330M	3000		
					470	7.3	4.3	1.8	4400	7	0.10	117.5	2R5TPE470M7	3000			
						7.3	4.3	1.8	3900	9	0.10	117.5	2R5TPE470M9	3000			
						7.3	4.3	1.8	3500	12	0.10	117.5	2R5TPE470MC	3000			
						7.3	4.3	1.8	3100	15	0.10	117.5	2R5TPE470MF	3000			
						7.3	4.3	1.8	2800	18	0.10	117.5	2R5TPE470MI	3000			
						680	7.3	4.3	2.8	3500	12	0.10	170.0	2R5TPE680MCL	2500		
							7.3	4.3	2.8	3100	15	0.10	170.0	2R5TPE680MFL	2500		
							7.3	4.3	2.8	1850	40	0.10	170.0	2R5TPE680MWL	2500		
							7.3	4.3	3.8	3900	15	0.15	250.0	2R5TPE1000MF	2000		
						1000	7.3	4.3	3.8	4400	12	0.15	375.0	2R5TPE1500MC	2000		
7.3	4.3	3.8	3900	15	0.15		375.0	2R5TPE1500MF	2000								
1500	7.3	4.3	3.8														
	7.3	4.3	3.8														

Characteristics list (4 to 10V)

Series	Rated voltage (V)	Rated temp. (°C)	Category voltage (V)	Category temp. (°C)	Rated capacitance (μF)	Case size (mm)			Size code	Specifications				Standard		Floor life		
						L	W	H		Ripple current ※1 (mA rms)	ESR ※2 (mΩ max.)	tan δ ※3	LC ※4 (μA)	Part number	Min. Packaging Qty (pcs)	Reflow temp. ≤260°C	Reflow temp. ≤250°C	
TPE	4	105	4	105	150	7.3	4.3	1.8	D2E	2800	18	0.10	60.0	4TPE150MI	3000	3		
		105	4	105	220	7.3	4.3	1.8		3100	15	0.10	88.0	4TPE220MF	3000			
		105	4	105		7.3	4.3	1.8		2800	18	0.10	88.0	4TPE220MI	3000			
		105	4	105	7.3	4.3	1.8	2400		25	0.10	88.0	4TPE220M	3000				
		105	4	105	7.3	4.3	1.8	1750		45	0.10	88.0	4TPE220MV	3000				
		105	4	105	7.3	4.3	1.8	2800		18	0.10	132.0	4TPE330MI	3000				
		105	4	105	330	470	7.3	4.3	1.8	D3L	2400	25	0.10	132.0	4TPE330M			3000
		105	4	105	7.3		4.3	1.8	1850		40	0.10	132.0	4TPE330MW	3000			
		105	4	105	7.3		4.3	2.8	3500		12	0.10	188.0	4TPE470MCL	2500			
		105	4	105	7.3	4.3	2.8	3100	15		0.10	188.0	4TPE470MFL	2500				
		105	4	105	7.3	4.3	2.8	2800	18		0.10	188.0	4TPE470MIL	2500				
		105	4	105	7.3	4.3	2.8	2400	25		0.10	188.0	4TPE470ML	2500				
	105	4	105	7.3	4.3	2.8	1850	40	0.10	188.0	4TPE470MWL	2500						
	105	6.3	105	6.3	105	100	7.3	4.3	1.8	D2E	2800	18	0.10	63.0	6TPE100MI	3000	2a	
	105		6.3	105	7.3		4.3	1.8	2400		25	0.10	63.0	6TPE100M	3000			
	105		6.3	105	7.3		4.3	1.8	1850		40	0.10	63.0	6TPE100MW	3000			
	105		6.3	105	7.3	4.3	1.8	3100	15		0.10	94.5	6TPE150MF	3000				
	105		6.3	105	7.3	4.3	1.8	2800	18		0.10	94.5	6TPE150MI	3000				
	105		6.3	105	7.3	4.3	1.8	2400	25		0.10	94.5	6TPE150M	3000				
	105		6.3	105	7.3	4.3	1.8	2800	18	0.10	138.6	6TPE220MI	3000					
	105		6.3	105	7.3	4.3	1.8	2400	25	0.10	138.6	6TPE220M	3000					
	85		5	105	220	470	7.3	4.3	1.8	D3L	2400	25	0.10	138.6	6TPE220MAP	3000		
	105		6.3	105	7.3		4.3	1.8	1850		40	0.10	138.6	6TPE220MW	3000			
	105		6.3	105	7.3		4.3	2.8	2800		18	0.10	138.6	6TPE220MIL	2500			
	85		5	105	7.3	4.3	1.8	D2E	2400		25	0.10	207.9	6TPE330MAP	3000			
	85	5	105	7.3	4.3	2.8	D3L	3900	9/500 kHz		0.10	207.9	6TPE330MA9EL	2500				
	105	6.3	105	7.3	4.3	2.8		3100	15		0.10	207.9	6TPE330MFL	2500				
	105	6.3	105	7.3	4.3	2.8		2800	18	0.10	207.9	6TPE330MIL	2500					
	105	6.3	105	7.3	4.3	2.8	2400	25	0.10	207.9	6TPE330ML	2500						
	85	5	105	7.3	4.3	3.8	D4	4400	10	0.10	207.9	6TPE330MAA	2000					
	85	5	105	7.3	4.3	1.4	D15E	1700	35	0.10	296.1	6TPE470MAZU	4000					
	105	6.3	105	7.3	4.3	3.8	470	D4	3500	18	0.15	296.1	6TPE470MI	2000				
	105	6.3	105	7.3	4.3	3.8			3000	25	0.15	296.1	6TPE470M	2000				
	105	6.3	105	7.3	4.3	3.8			2500	35	0.15	296.1	6TPE470MZ	2000				
	105	6.3	105	7.3	4.3	3.8			2350	40	0.15	296.1	6TPE470MW	2000				
	105	6.3	105	7.3	4.3	3.8			3500	18	0.15	428.4	6TPE680MI	2000				
105	6.3	105	7.3	4.3	3.8	3000			25	0.15	428.4	6TPE680M	2000					
105	10	105	10	105	68	7.3	4.3	1.8	D2E	2400	25	0.10	68.0	10TPE68M	3000	3		
105		10	105	7.3		4.3	1.8	1850		40	0.10	68.0	10TPE68MW	3000				
105		10	105	150	220	7.3	4.3	2.8	D3L	2400	25	0.10	150.0	10TPE150MPL	2500			
105		10	105	7.3		4.3	2.8	2800		18	0.10	220.0	10TPE220MIL	2500				
105		10	105	7.3		4.3	3.8	2400		25	0.10	220.0	10TPE220ML	2500				
105		10	105	7.3		4.3	3.8	3000		25	0.10	330.0	10TPE330M	2000				

※1: Ripple current (100 kHz/ +45 °C)

※2: ESR (100 kHz/+20 °C)

※3: tanδ (120 Hz/+20 °C)

※4: After 5 minutes

◆Please refer to each page in this catalog for "Reflow conditions" and "Taping specifications".

◆Please refer to page 42 for floor life level.

※: Small order quantity (500 pcs/reel) is available with TPE series. Please contact our sales representative if you prefer it.

SP-Cap

Guidelines and Precautions
Mounting specifications
Packing specifications

Selection guide

Surface mount type

Catalog EOL models

POSCAP

Guidelines and Precautions
Mounting specifications
Packing specifications

Selection guide
Line-up
Series system diagram
Size list
Products list

TPG
TPS
TPSF
TQS
TPE
TPF
TQC
TA
TV
TH
TPB
TC
TDC
TPC

Catalog Deletion models

Catalog EOL models

OS-CON

Guidelines and Precautions
Mounting specifications
Packing specifications

Selection guide

Surface mount type

Radial lead type

Catalog EOL models

Hybrid

Guidelines and Precautions
Mounting specifications
Packing specifications

Selection guide

Surface mount type

Radial lead type



Super low ESR (5 mΩ)

Large capacitance (1000 μF max.)

RoHS compliance, Halogen free

SP-Cap

Guidelines and Precautions
Mounting specifications
Packing specifications

Selection guide

Surface mount type

Catalog EOL models

POSCAP

Guidelines and Precautions
Mounting specifications
Packing specifications

Line-up
Series system diagram
Size list

Products list

- TPG
- TPS
- TPSF
- TQS
- TPE
- TPF**
- TQC
- TA
- TV
- TH
- TPB
- TC
- TDC
- TPC

Surface mount type

Catalog Deletion models

Catalog EOL models

OS-CON

Guidelines and Precautions
Mounting specifications
Packing specifications

Selection guide

Surface mount type

Radial lead type

Catalog EOL models

Hybrid

Guidelines and Precautions
Mounting specifications
Packing specifications

Selection guide

Surface mount type

Radial lead type

Specifications

Items	Specifications		
	D2E	D3L	D4
Size code	D2E	D3L	D4
Category temperature range	-55 °C to +105 °C		
Rated voltage range	2 V	2.5 V to 10 V	2.5 V to 6.3 V
Category voltage range	2 V	2.5 V to 10 V	2.5 V to 6.3 V
Rated capacitance range	220 μF to 330 μF	150 μF to 680 μF	470 μF to 1000 μF
Capacitance tolerance	±20 % (120 Hz/+20 °C)		
Leakage current	Please see the attached characteristics list		
Dissipation factor (tanδ)	Please see the attached characteristics list		
Surge voltage (V)	Rated voltage x1.15		
Endurance	+105 °C, 2000 h, rated voltage applied		
	Capacitance change	Within ±20 % of the initial value	
	tanδ	≤ 1.5 times of the initial limit	
	DC leakage current	Within the initial limit	
Damp heat (Steady state)	+60 °C, 90 % to 95 % RH, 500 h, No-applied voltage		
	Capacitance change	Within +50 %, -20 % of the initial value (2TPF220M6, 2TPF330M6, ETPF1000M6H(5H))	
	tanδ	Within +40 %, -20 % of the initial value (Except for above model)	
	DC leakage current	≤ 3 times of the initial limit	

Marking and Dimensions

(unit : mm)

Size code	L ±0.3	W ±0.2	H ±0.2 ※1	S ±0.2	W1 ±0.1
D2E	7.3	4.3	1.8	1.3	2.4
D3L	7.3	4.3	2.8	1.3	2.4
D4	7.3	4.3	3.8	1.3	2.4

※1 ±0.1 : D2E

R. voltage (V)	2.0	2.5	4.0	6.3	10.0
Code	d	e	g	j	A

Characteristics list

Series	Rated voltage (V)	Rated temp. (°C)	Category voltage (V)	Category temp. (°C)	Rated capacitance (μF)	Case size (mm)			Size code	Specifications				Standard		Floor life		
						L	W	H		Ripple current ※1 (mA rms)	ESR ※2 (mΩ max.)	tan δ ※3	LC ※4 (μA)	Part number	Min. Packaging Qty (pcs)	Reflow temp. ≤260°C	Reflow temp. ≤250°C	
TPF	2	105	2	105	220	7.3	4.3	1.8	D2E	4700	6	0.10	88.0	2TPPF220M6	3000	-		
		105	2	105	330	7.3	4.3	1.8		4700	6	0.10	132.0	2TPPF330M6	3000			
	2.5	105	2.5	105	470	7.3	4.3	2.8	D3L	4400	7	0.10	82.5	2R5TPF330M7L	2500	3	2a	
		105	2.5	105		7.3	4.3	2.8		4400	6	0.10	117.5	2R5TPF470M6L	2500			
		105	2.5	105		7.3	4.3	2.8		4400	7	0.10	117.5	2R5TPF470M7L	2500			
		105	2.5	105		7.3	4.3	2.8		4400	10	0.10	117.5	2R5TPF470ML	2500			
		105	2.5	105	680	7.3	4.3	3.8	D4	6100	5	0.10	117.5	ETPF470M5H	2000			
		105	2.5	105		7.3	4.3	2.8		3850	9	0.10	117.5	2R5TPF470M9L	2500			
		105	2.5	105	1000	7.3	4.3	2.8	D3L	4400	6	0.10	170.0	2R5TPF680M6L	2500			
		105	2.5	105		7.3	4.3	2.8		4400	7	0.10	170.0	2R5TPF680M7L	2500			
		105	2.5	105		7.3	4.3	2.8		4400	10	0.10	170.0	2R5TPF680ML	2500			
		105	2.5	105		7.3	4.3	3.8		D4	6100	5	0.10	170.0	ETPF680M5H			2000
		105	2.5	105	7.3	4.3	3.8	2700	25		0.10	170.0	ETPF680MPH	2000				
		105	2.5	105	330	7.3	4.3	2.8	D3L	6100	5	0.10	250.0	ETPF1000M5H	2000			
		105	2.5	105		7.3	4.3	3.8		5600	6	0.10	250.0	ETPF1000M6H	2000			
		105	4	105		7.3	4.3	2.8		D4	3900	9	0.10	132.0	4TPF330M9L			2500
	105	4	105	7.3		4.3	2.8	4000			12	0.10	132.0	4TPF330ML	2500			
	105	4	105	7.3	4.3	2.8	3550	15	0.10		132.0	4TPF330MFL	2500					
	105	4	105	7.3	4.3	2.8	4400	10	0.10		188.0	4TPF470ML	2500					
	105	4	105	680	7.3	4.3	3.8	D4	4400	10	0.10	272.0	4TPF680MAH	2000				
	105	4	105		7.3	4.3	3.8		3550	15	0.10	272.0	4TPF680MFH	2000				
	105	4	105	2350	7.3	4.3	3.8	D3L	2350	35	0.10	272.0	4TPF680MZH	2000				
	105	4	105		7.3	4.3	2.8		2750	25	0.10	94.5	6TPF150MPL	2500				
	6.3	6.3	105	105	150	220	7.3	4.3	2.8	D3L	6100	5	0.10	138.6	6TPF220M5L	2500	3	
											5550	6	0.10	138.6	6TPF220M6L	2500		
											4600	9	0.10	138.6	6TPF220M9L	2500		
											4000	12	0.10	138.6	6TPF220ML	2500		
											3550	15	0.10	138.6	6TPF220MFL	2500		
											2750	25	0.10	138.6	6TPF220MPL	2500		
											3900	9	0.10	207.9	6TPF330M9L	2500		
3650											10	0.10	207.9	6TPF330MAL	2500			
4400											10	0.10	296.1	6TPF470MAH	2500			
3550											15	0.10	296.1	6TPF470MFH	2000			
10	105	10	105	150	7.3	4.3	2.8	D3L	3600	15	0.10	150.0	10TPF150ML	2500	-			

※1: Ripple current (100 kHz/ +45 °C)

※2: ESR (100 kHz/+20 °C)

※3: tanδ (120 Hz/+20 °C)

※4: After 5 minutes

◆Please refer to each page in this catalog for "Reflow conditions" and "Taping specifications".

◆Please refer to page 42 for floor life level.

※: Small order quantity (500 pcs/reel) is available with TPF series. Please contact our sales representative if you prefer it.

SP-Cap

Guidelines and Precautions
Mounting specifications
Packing specifications

Selection guide

Surface mount type

Catalog EOL models

POSCAP

Guidelines and Precautions
Mounting specifications
Packing specifications

Selection guide
Line-up
Series system diagram
Size list
Products list

TPG
TPS
TPSF
TQS
TPE
TPF
TQC
TA
TV
TH
TPB
TC
TDC
TPC

Catalog Deletion models

Catalog EOL models

OS-CON

Guidelines and Precautions
Mounting specifications
Packing specifications

Selection guide

Surface mount type

Radial lead type

Catalog EOL models

Hybrid

Guidelines and Precautions
Mounting specifications
Packing specifications

Selection guide

Surface mount type

Radial lead type



High voltage (35 V max.)

RoHS compliance, Halogen free

SP-Cap

Guidelines and Precautions
Mounting specifications
Packing specifications

Selection guide

Surface mount type

Catalog EOL models

POSCAP

Guidelines and Precautions
Mounting specifications
Packing specifications

Line-up

Series system diagram
Size list

Products list

- TPG
- TPS
- TPSF
- TQS
- TPE
- TPF
- TQC**
- TA
- TV
- TH
- TPB
- TC
- TDC
- TPC

Surface mount type

Catalog Deletion models

Catalog EOL models

OS-CON

Guidelines and Precautions
Mounting specifications
Packing specifications

Selection guide

Surface mount type

Hybrid

Guidelines and Precautions
Mounting specifications
Packing specifications

Selection guide

Surface mount type

Radial lead type

Specifications

Items	Specifications	
Size code	B2	
Category temperature range	-55 °C to +105 °C	
Rated voltage range	16 V to 35 V	
Category voltage range	16 V to 35 V	
Rated capacitance range	3.9 μF to 47 μF	
Capacitance tolerance	±20 % (120 Hz/+20 °C)	
Leakage current	Please see the attached characteristics list	
Dissipation factor(tanδ)	Please see the attached characteristics list	
Surge voltage(V)	Rated voltage x1.15	
Endurance	+105 °C, 2000 h(16TQC33MYFB: 1000 h), rated voltage applied	
	Capacitance change	Within±20 % of the initial value
	tanδ	≤ 1.5 times of the initial limit
	DC leakage current	Within the initial limit
Damp heat(Steady state)	+60 °C, 90 % to 95 % RH, 500 h, No-applied voltage	
	Capacitance change	Within+40 %, -20 % of the initial value
	tanδ	≤ 1.5 times of the initial limit
	DC leakage current	≤ 3 times of the initial limit

Marking and Dimensions

(unit : mm)

Size code	L ±0.2	W ±0.2	H ±0.1	S ±0.2	W1 ±0.1
B2	3.5	2.8	1.9	0.8	2.2

R. voltage (V)	16	20	25	35
Code	C	D	E	V

R. cap.(μF)	3.9	5.6	8.2	10	15	22	33	47
Code	Q6	U6	Y6	A7	E7	J7	N7	S7

Characteristics list

Series	Rated voltage (V)	Rated temp. (°C)	Category voltage (V)	Category temp. (°C)	Rated capacitance (μF)	Case size (mm)			Size code	Specifications				Standard		Floor life		
						L	W	H		Ripple current ※1 (mA rms)	ESR ※2 (mΩ max.)	tan δ ※3	LC ※4 (μA)	Part number	Min. Packaging Qty (pcs)	Reflow temp. ≤260°C	Reflow temp. ≤250°C	
TQC	16	105	16	105	10	3.5	2.8	1.9	B2	800	100	0.10	48.0	16TQC10M	2000	-	3	
						3.5	2.8	1.9		1000	90	0.10	72.0	16TQC15M	2000			
						3.5	2.8	1.9		1000	90	0.10	35.2	16TQC22MYFB	2000			
						3.5	2.8	1.9		1000	90	0.10	158.4	16TQC33MYFB	2000			
						3.5	2.8	1.9		1000	90	0.15	225.6	16TQC47MYFB	2000			
	20	105	20	105	105	8.2	3.5	2.8		1.9	800	100	0.10	49.2	20TQC8R2M	2000	-	3
							3.5	2.8		1.9	1000	90	0.10	132.0	20TQC22MYFB	2000		
							3.5	2.8		1.9	800	100	0.10	42.0	25TQC5R6M	2000		
							3.5	2.8		1.9	900	100	0.10	25.0	25TQC10MEB	2000		
	25	105	25	105	105	10	3.5	2.8		1.9	900	100	0.10	112.5	25TQC15MYFB	2000	-	3
							3.5	2.8		1.9	900	100	0.10	112.5	25TQC15MYFB	2000		
							3.5	2.8		1.9	900	100	0.10	112.5	25TQC15MYFB	2000		
							3.5	2.8		1.9	1100	100	0.10	165.0	25TQC22MYFB	2000		
	35	105	35	105	105	3.9	3.5	2.8		1.9	500	400	0.10	40.9	35TQC3R9MYF	2000	-	3
							3.5	2.8		1.9	900	150	0.15	105.0	35TQC10MYFB	2000		
							3.5	2.8		1.9	750	200	0.15	105.5	35TQC10MXB	2000		

※1: Ripple current (100 kHz/ +105 °C) ※2: ESR (100 kHz/+20 °C) ※3: tanδ (120 Hz/+20 °C) ※4: After 5 minutes

◆Please refer to each page in this catalog for "Reflow conditions" and "Taping specifications".

◆Please refer to page 42 for floor life level.

※: Small order quantity (500 pcs/reel) is available with TQC series. Please contact our sales representative if you prefer it.



High voltage (35 V max.)

RoHS compliance, Halogen free

Specifications

Items	Specifications			
	Size code	D12	D15	D2
Category temperature range	-55 °C to +105 °C			
Rated voltage range	16 V	16 V to 25 V	16 V to 35 V	16 V to 25 V
Category voltage range	16 V	16 V to 25 V	16 V to 35 V	16 V to 25 V
Rated capacitance range	33 μF	22 μF to 47 μF	10 μF to 150 μF	68 μF to 220 μF
Capacitance tolerance	±20 % (120 Hz/+20 °C)			
Leakage current	Please see the attached characteristics list			
Dissipation factor(tanδ)	Please see the attached characteristics list			
Surge voltage(V)	Rated voltage x1.15			
Endurance	+105 °C, 2000 h, rated voltage applied			
	Capacitance change	Within±20 % of the initial value		
	tanδ	≤ 1.5 times of the initial limit		
	DC leakage current	Within the initial limit		
Damp heat (Steady state)	+60 °C, 90 % to 95 % RH, 500 h, No-applied voltage			
	Capacitance change	Within+40 %, -20 % of the initial value		
	tanδ	≤ 1.5 times of the initial limit		
	DC leakage current	≤ 3 times of the initial limit		

Marking and Dimensions

(unit : mm)

Size code	L ±0.2 ※1	W ±0.2	H ±0.1 ※2	S ±0.2	W1 ±0.1
D12	7.3	4.3	1.15	1.3	2.4
D15	7.3	4.3	1.4	1.3	2.4
D2	7.3	4.3	1.9	1.3	2.4
D3L	7.3	4.3	2.8	1.3	2.4

※1 D3L size (±0.3) ※2 D12 size (±0.05), D3L size (±0.2)

R. voltage (V)	16	20	25	35
Code	C	D	1E	V

Characteristics list

Series	Rated voltage (V)	Rated temp. (°C)	Category voltage (V)	Category temp. (°C)	Rated capacitance (μF)	Case size (mm)			Size code	Specifications				Standard		Floor life			
						L	W	H		Ripple current ※1 (mA rms)	ESR ※2 (mΩ max.)	tan δ ※3	LC ※4 (μA)	Part number	Min. Packag. Qty (pcs)	Reflow temp. ≤260°C	Reflow temp. ≤250°C		
TQC	16	105	16	105	33	7.3	4.3	1.15	D12	1800	40	0.10	52.8	16TQC33MYFS	4500	-	3		
						7.3	4.3	1.9	D2	1400	70	0.10	52.8	16TQC33MYFD	3000				
						7.3	4.3	1.4	D15	1500	55	0.10	75.2	16TQC47MYFT	3000				
					47	7.3	4.3	1.9	D2	1800	40	0.10	75.2	16TQC47MW	3000				
						7.3	4.3	1.9		1450	55	0.10	75.2	16TQC47MYFD	3000				
						7.3	4.3	1.9		1250	70	0.10	75.2	16TQC47MBD	3000				
						7.3	4.3	1.9		1500	50	0.10	108.8	16TQC68MYF	2500				
						7.3	4.3	1.9		1800	50	0.10	160.0	16TQC100MYF	3000				
						7.3	4.3	2.8		D3L	1800	50	0.10	240.0	16TQC150MYF			3000	
						7.3	4.3	1.9		D2	1500	70	0.15	240.0	1CTQC15173F1			3000	
	20	105	20	105	105	150	7.3	4.3	2.8	D3L	1750	50	0.10	352.0	16TQC220MD3			2500	
							7.3	4.3	1.9	D2	1200	90	0.10	44.0	20TQC22MQD			3000	
							7.3	4.3	1.9	D2	1400	60	0.10	66.0	20TQC33MYFD			3000	
						47	7.3	4.3	1.9	D2	1450	55	0.10	94.0	20TQC47MYF			3000	
							7.3	4.3	1.4		D15	1500	55	0.10	94.0			20TQC47MYFT	3000
							7.3	4.3	1.9		D2	1250	100	0.15	200.0			20TQC100MD2	3000
							7.3	4.3	2.8		D3L	1700	55	0.10	200.0			20TQC100MYF	2500
							7.3	4.3	1.9		D2	1500	45	0.10	38.0			25TQC15MV	3000
							7.3	4.3	1.9			1000	90	0.10	38.0			25TQC15MYFD	3000
							7.3	4.3	1.9			1500	45	0.10	55.0			25TQC22MV	3000
7.3	4.3	1.9	1400	60	0.10	55.0	25TQC22MYFD	3000											
25	105	25	105	105	22	7.3	4.3	1.4	D15	1400	70	0.10	55.0	25TQC22MYFT	3000				
						7.3	4.3	1.9	D2	1400	60	0.10	82.5	25TQC33MYF	3000				
						7.3	4.3	2.8	D3L	1400	70	0.10	170.0	25TQC68MYF	2500				
					15	7.3	4.3	2.8	D3L	1600	60	0.10	250.0	25TQC100MD3	2500				
						7.3	4.3	1.9	D2	1000	120	0.10	35.0	35TQC10M	3000				
						7.3	4.3	1.9		1000	120	0.10	35.0	35TQC10MYF	3000				
						7.3	4.3	1.9		900	150	0.10	52.5	35TQC15MYF	3000				

※1: Ripple current (100 kHz/ +105 °C) ※2: ESR (100 kHz/+20 °C) ※3: tanδ (120 Hz/+20 °C) ※4: After 5 minutes

◆Please refer to each page in this catalog for "Reflow conditions" and "Taping specifications".

◆Please refer to page 42 for floor life level.

※: Small order quantity (500 pcs/reel) is available with TQC series. Please contact our sales representative if you prefer it.

Design and specifications are each subject to change without notice. Ask factory for the current technical specifications before purchase and/or use.

Should a safety concern arise regarding this product, please be sure to contact us immediately.

SP-Cap

Guidelines and Precaution
Mounting specifications
Packing specifications

Selection guide

Surface mount type

POSCAP

Guidelines and Precautions
Mounting specifications
Packing specifications

Line-up
Series system diagram
Size list
Products list

- TPG
- TPS
- TPSF
- TQS
- TPE
- TPF
- TQC**
- TA
- TV
- TH
- TPB
- TC
- TDC
- TPC

Catalog Deletion models

Catalog EOL models

OS-CON

Guidelines and Precautions
Mounting specifications
Packing specifications

Selection guide

Surface mount type

Radial lead type

Catalog EOL models

Hybrid

Guidelines and Precautions
Mounting specifications
Packing specifications

Selection guide

Surface mount type

Radial lead type

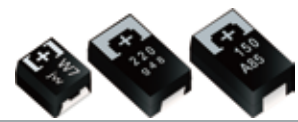

Guaranteed at 85 °C85 %RH

RoHS compliance, Halogen free

This product is not intended for use in any driving application or any other critical functions that affect passenger safety (e.g. Powertrain, ABS, Engine ECU, Airbag, etc.)
If the intended use of TA/TV series products is for use in other automotive related applications, please contact our sales team. All requests are subject to approval.

SP-Cap

Guidelines and Precautions
Mounting specifications
Packing specifications

Selection guide

Surface mount type

Catalog EOL models

POSCAP

Guidelines and Precautions
Mounting specifications
Packing specifications

Line-up
Series system diagram
Size list

Products list

- TPG
- TPS
- TPSF
- TQS
- TPE
- TPF
- TQC
- TA**
- TV
- TH
- TPB
- TC
- TDC
- TPC

Surface mount type

Catalog Deletion models

OS-CON

Guidelines and Precautions
Mounting specifications
Packing specifications

Selection guide

Surface mount type

Specifications

Items	Specifications		
	B2	D2E	D3L
Size code	B2	D2E	D3L
Category temperature range	-55 °C to +105 °C		
Rated voltage range	4 V to 10 V	2.5 V to 10 V	
Category voltage range	4 V to 10 V	2.5 V to 10 V	
Rated capacitance range	47 μF to 100 μF	68 μF to 470 μF	150 μF to 680 μF
Capacitance tolerance	±20 % (120 Hz/+20 °C)		
Leakage current	Please see the attached characteristics list		
Dissipation factor(tanδ)	Please see the attached characteristics list		
Surge voltage(V)	Rated voltage x1.15		
Endurance	+105 °C, 2000 h, (B2 size : 1000 h)rated voltage applied		
	Capacitance change	Within±20 % of the initial value	
	tanδ	≤ 1.5 times of the initial limit	
	DC leakage current	Within the initial limit	
Damp heat(Steady state)	+85 °C, 85 % to 90 % RH, 500 h, rated voltage applied		
	Capacitance change	Within +50 %, -20 % of the initial value(2R5TAE470M(F), 2R5TAE330M(F, I), 2R5TAE220M(F, 9))	
	tanδ	Within+40 %, -20 % of the initial value(Except for above model)	
	DC leakage current	≤ 1.5 times of the initial limit	
DC leakage current	Within the initial limit		

Marking and Dimensions

(B2 Size)

R. capacitance code

Polarity marking(+)

R. voltage code

Lot. No.

(D2E, D3L Size)

R. capacitance (μF)

Polarity marking(+)

R. voltage code

Lot. No.

(unit : mm)

Size code	L ±0.3 ※1	W ±0.2	H ±0.2 ※2	S ±0.2	W1 ±0.1
B2	3.5	2.8	1.9	0.8	2.2
D2E	7.3	4.3	1.8	1.3	2.4
D3L	7.3	4.3	2.8	1.3	2.4

※1 ±0.2 : B2 ※2 ±0.1 : B2, D2E

R. voltage (V)	2.5	4.0	6.3	10.0
Code	e	g	j	A

B2 size

R. cap. (μF)	47	68	100
Code	S7	W7	A8

Characteristics list

Series	Rated voltage (V)	Rated temp. (°C)	Category voltage (V)	Category temp. (°C)	Rated capacitance (μF)	Case size (mm)			Size code	Specifications				Standard		Floor life	
						L	W	H		Ripple current ※1 (mA rms)	ESR ※2 (mΩ max.)	tan δ ※3	LC ※4 (μA)	Part number	Min. Packaging Qty (pcs)	Reflow temp. ≤260°C	Reflow temp. ≤250°C
TA	2.5	105	2.5	105	220	7.3	4.3	1.8	D2E	3900	9	0.10	110.0	2R5TAE220M9	3000	3	3
						7.3	4.3	1.8		3100	15	0.10	55.0	2R5TAE220MF	3000		
			7.3	4.3	1.8	2400	25	0.10		55.0	2R5TAE220M	3000					
			7.3	4.3	1.8	3100	15	0.10		82.5	2R5TAE330MF	3000					
			7.3	4.3	1.8	2800	18	0.10		82.5	2R5TAE330MI	3000					
			7.3	4.3	1.8	2400	25	0.10		82.5	2R5TAE330M	3000					
		7.3	4.3	1.8	3100	15	0.10	117.5	2R5TAE470MF	3000							
		7.3	4.3	1.8	2400	25	0.10	117.5	2R5TAE470M	3000							
		7.3	4.3	2.8	3100	15	0.10	170.0	2R5TAE680MFL	2500							
		7.3	4.3	2.8	2400	25	0.10	170.0	2R5TAE680ML	2500							
		7.3	4.3	1.8	3100	15	0.10	170.0	2R5TAE680MFL	2500							
		7.3	4.3	1.8	2400	25	0.10	170.0	2R5TAE680ML	2500							
	4	105	4	105	100	B2	3.5	2.8	1.9	1100	70	0.08	40.0	4TAB100M	2000		
	7.3						4.3	1.8	2800	18	0.10	88.0	4TAE220MI	3000			
	7.3		4.3	1.8	2400		25	0.10	88.0	4TAE220M	3000						
	7.3		4.3	2.8	2800		18	0.10	188.0	4TAE470MIL	2500						
	7.3		4.3	2.8	2400		25	0.10	188.0	4TAE470ML	2500						
	7.3		4.3	2.8	2400		25	0.10	188.0	4TAE470ML	2500						
	6.3	105	6.3	105	47	B2	3.5	2.8	1.9	1100	70	0.08	29.6	6TAB47M	2000		
	3.5						2.8	1.9	1100	70	0.08	42.8	6TAB68M	2000			
	7.3		4.3	1.8	2400		25	0.10	94.5	6TAE150M	3000						
	7.3		4.3	1.8	2800		18	0.10	138.6	6TAE220MI	3000						
	7.3		4.3	1.8	2400		25	0.10	138.6	6TAE220M	3000						
	7.3		4.3	2.8	2400		25	0.10	207.9	6TAE330ML	2500						
10	105	10	105	47	B2	3.5	2.8	1.9	1100	70	0.08	47.0	10TAB47M	2000			
7.3						4.3	1.8	2400	25	0.10	68.0	10TAE68M	3000				
7.3		4.3	2.8	2400		25	0.10	150.0	10TAE150ML	2500							
7.3		4.3	2.8	2400		25	0.10	150.0	10TAE150ML	2500							
7.3		4.3	2.8	2400		25	0.10	220.0	10TAE220ML	2500							
7.3		4.3	2.8	2400		25	0.10	220.0	10TAE220ML	2500							

※1: Ripple current (100 kHz/ +45 °C) ※2: ESR (100 kHz/+20 °C) ※3: tanδ (120 Hz/+20 °C) ※4: After 5 minutes

◆Please refer to each page in this catalog for "Reflow conditions" and "Taping specifications".

◆Please refer to page 42 for floor life level.

Design and specifications are each subject to change without notice. Ask factory for the current technical specifications before purchase and/or use.
Should a safety concern arise regarding this product, please be sure to contact us immediately.



Guaranteed at 85 °C 85 %RH

Guaranteed at 125 °C

RoHS compliance, Halogen free

This product is not intended for use in any driving application or any other critical functions that affect passenger safety (e.g. Powertrain, ABS, Engine ECU, Airbag, etc.)
If the intended use of TA/TV series products is for use in other automotive related applications, please contact our sales team. All requests are subject to approval.

Specifications

Items	Specifications		
Size code	D2E		D3L
Category temperature range	-55 °C to +125 °C		
Rated voltage range	6.3 V to 10 V		10 V
Category voltage range	4 V to 6.3 V		6.3 V
Rated capacitance range	68 μF to 150 μF		150 μF
Capacitance tolerance	±20 % (120 Hz/+20 °C)		
Leakage current	Please see the attached characteristics list		
Dissipation factor (tan δ)	Please see the attached characteristics list		
Surge voltage (V)	Rated voltage x 1.15		
Endurance	+125 °C, 1000 h, category voltage applied (105 °C 2000 h, rated voltage applied)		
	temp	125 °C	105 °C
	Capacitance change	Within ±20 % of the initial value	Within ±20 % of the initial value
	tan δ	≤ 2 times of the initial limit	≤ 1.5 times of the initial limit
Damp heat (Steady state)	+85 °C, 85 % to 90 % RH, 500 h, rated voltage applied		
	Capacitance change	Within +40 %, -20 % of the initial value	
	tan δ	≤ 1.5 times of the initial limit	
	DC leakage current	Within the initial limit	

Marking and Dimensions

Size code	L ±0.3	W ±0.2 ※1	H ±0.2	S ±0.2	W1 ±0.1
D2E	7.3	4.3	1.8	1.3	2.4
D3L	7.3	4.3	2.8	1.3	2.4

※1 ±0.1 : D2E

R. voltage (V)	6.3	10.0
Code	j	A

Characteristics list

Series	Rated voltage (V)	Rated temp. (°C)	Category voltage (V)	Category temp. (°C)	Rated capacitance (μF)	Case size (mm)			Size code	Specifications				Standard		Floor life	
						L	W	H		Ripple current ※1 (mA rms)	ESR ※2 (mΩ max.)	tan δ ※3	LC ※4 (μA)	Part number	Min. Packaging Qty (pcs)	Reflow temp. ≤260 °C	Reflow temp. ≤250 °C
TV	6.3	105	4	125	150	7.3	4.3	1.8	D2E	2400	25	0.10	94.5	6TVE150M	3000	5	3
										2400	25	0.10	68.0	10TVE68M	3000		
	10	105	6.3	125	68	7.3	4.3	1.8	D3L	2400	25	0.10	150.0	10TVE150ML	2500		

※1: Ripple current (100 kHz/ +45 °C)

※2: ESR (100 kHz/+20 °C)

※3: tan δ (120 Hz/+20 °C)

※4: After 5 minutes

◆Please refer to each page in this catalog for "Reflow conditions" and "Taping specifications".

◆Please refer to page 42 for floor life level.

SP-Cap

Guidelines and Precautions
Mounting specifications
Packing specifications

Selection guide

Surface mount type

POSCAP

Guidelines and Precautions
Mounting specifications
Packing specifications

Line-up
Series system diagram
Size list

Products list

- TPG
- TPS
- TPSF
- TQS
- TPE
- TPF
- TQC
- TA
- TV**
- TH
- TPB
- TC
- TDC
- TPC

Catalog Deletion models

Catalog EOL models

OS-CON

Guidelines and Precautions
Mounting specifications
Packing specifications

Selection guide

Surface mount type

Radial lead type

Catalog EOL models

Hybrid

Guidelines and Precautions
Mounting specifications
Packing specifications

Selection guide

Surface mount type

Radial lead type



Guaranteed at 125 °C 1000 h

RoHS compliance, Halogen free

Specifications

Items	Specifications			
	D2E	D2	D3L	D4
Size code				
Category temperature range	-55 °C to +125 °C			
Rated voltage range	2.5 V to 6.3 V	2.5 V to 10 V	4 V to 6.3 V	6.3 V to 10 V
Category voltage range	1.6 V ~ 4 V	1.6 V to 6.3 V	2.5 V.DC to 4 V.DC	4 V to 6.3 V
Rated capacitance range	150 μF to 330 μF	68 μF to 220 μF	220 μF to 330 μF	220 μF to 470 μF
Capacitance tolerance	±20 % (120 Hz/+20 °C)			
Leakage current	Please see the attached characteristics list			
Dissipation factor(tanδ)	Please see the attached characteristics list			
Surge voltage(V)	Rated voltage x1.15			
Endurance	+125 °C, 1000 h, Category voltage applied			
	Capacitance change	Within±20 % of the initial value		
	tanδ	≤ 2 times of the initial limit		
Damp heat(Steady state)	+60 °C, 90 % to 95 % RH, 500 h, No-applied voltage			
	Capacitance change	Within+40 %, -20 % of the initial value		
	tanδ	≤ 1.5 times of the initial limit		
DC leakage current	≤ 2 times of the initial limit			
	≤ 3 times of the initial limit			

Marking and Dimensions

(D2E, D3L size)

(D2, D4 size)

Size code	L ±0.3※1	W ±0.2	H ±0.1 ※2	S ±0.2	W1 ±0.1
D2E	7.3	4.3	1.8	1.3	2.4
D2	7.3	4.3	1.9	1.3	2.4
D3L	7.3	4.3	2.8	1.3	2.4
D4	7.3	4.3	3.8	1.3	2.4

※1 ±0.2:D2 ※2 ±0.2:D3L,D4

R. voltage (V)	2.5	4.0	6.3	10.0
Code	e	g	j	A

Characteristics list

Series	Rated voltage (V)	Rated temp. (°C)	Category voltage (V)	Category temp. (°C)	Rated capacitance (μF)	Case size(mm)			Size code	Specifications				Standard		Floor life		
						L	W	H		Ripple current ※1 (mA rms)	ESR ※2 (mΩ max.)	tan δ ※3	LC ※4 (μA)	Part number	Min. Packaging Qty (pcs)	Reflow temp. ≤260°C	Reflow temp. ≤250°C	
THB	4	105	2.5	125	330	7.3	4.3	2.8	D3L	2000	40	0.10	132.0	4THB330ML	2500	-	5	
										2000	40	0.10	138.6	6THB220ML	2500			
	6.3	105	4	125	330	7.3	4.3	3.8		D4	3000	40	0.10	207.9	6THB330M			2000
											3000	35	0.15	296.1	6THB470M			2000
		105	6.3	125	220	7.3	4.3	3.8			3000	40	0.10	220.0	10THB220M			2000
											3000	35	0.10	330.0	10THB330M			2000
THC	2.5	105	1.6	125	220	7.3	4.3	1.9	D2	1700	45	0.10	55.0	2R5THC220M	3000			
										1900	40	0.10	94.5	6THC150M	3000			
										1700	45	0.10	68.0	10THC68M	3000			
THE	2.5	105	1.6	125	330	7.3	4.3	1.8	D2E	3100	15	0.10	82.5	2R5THE330MF	3000			
										2800	18	0.10	82.5	2R5THE330MI	3000			
										2400	25	0.10	82.5	2R5THE330M	3000			
	4	105	2.5	125	220	7.3	4.3	1.8		3100	15	0.10	88.0	4THE220MF	3000			
										2800	18	0.10	88.0	4THE220MI	3000			
										2400	25	0.10	88.0	4THE220M	3000			
	6.3	105	4	125	150	7.3	4.3	1.8		2800	18	0.10	94.5	6THE150MI	3000			
										2400	25	0.10	94.5	6THE150M	3000			

※1:Ripple current (100 kHz/ +45 °C) ※2:ESR (100 kHz/+20 °C) ※3:tanδ (120 Hz/+20 °C) ※4:After 5 minutes

◆Please refer to each page in this catalog for "Reflow conditions" and "Taping specifications".

◆Please refer to page 42 for floor life level.

Design and specifications are each subject to change without notice. Ask factory for the current technical specifications before purchase and/or use. Should a safety concern arise regarding this product, please be sure to contact us immediately.



Standard

RoHS compliance, Halogen free

Specifications

Items	Specifications		
	B2	D3L	D4
Size code	B2	D3L	D4
Category temperature range	-55 °C to +105 °C		
Rated voltage range	4 V to 10 V		6.3 V to 10 V
Category voltage range	4 V to 10 V		6.3 V to 10 V
Rated capacitance range	33 μF to 68 μF	150 μF to 330 μF	220 μF to 470 μF
Capacitance tolerance	±20 % (120 Hz/+20 °C)		
Leakage current	Please see the attached characteristics list		
Dissipation factor(tanδ)	Please see the attached characteristics list		
Surge voltage(V)	Rated voltage x1.15		
Endurance	+105 °C 2000 h, (B2 size:1000 h) rated voltage applied *Rated temp. 85 °C 1000 h rated voltage applied		
	Capacitance change	Within±20 % of the initial value	
	tanδ	≤ 1.5 times of the initial limit	
	DC leakage current	Within the initial limit	
Damp heat(Steady state)	+60 °C, 90 % to 95 % RH, 500 h, No-applied voltage		
	Capacitance change	Within+40 %, -20 % of the initial value	
	tanδ	≤ 1.5 times of the initial limit	
	DC leakage current	≤ 3 times of the initial limit	

Marking and Dimensions

(B2 size)

(D3L size)

(D4 size)

(unit : mm)

Size code	L ±0.3※1	W ±0.2	H ±0.2※2	S ±0.2	W1 ±0.1
B2	3.5	2.8	1.9	0.8	2.2
D3L	7.3	4.3	2.8	1.3	2.4
D4	7.3	4.3	3.8	1.3	2.4

※1 ±0.2:B2 ※2 ±0.1:B2

R. voltage (V)	4.0	6.3	10.0
Code	g	j	A

B2 size

R. cap.(μF)	33	47	68
Code	N7	S7	W7

Characteristics list

Series	Rated voltage (V)	Rated temp. (°C)	Category voltage (V)	Category temp. (°C)	Rated capacitance (μF)	Case size (mm)			Size code	Specifications				Standard		Floor life			
						L	W	H		Ripple current ※1 (mA rms)	ESR ※2 (mΩ max.)	tan δ ※3	LC ※4 (μA)	Part number	Min. Packaging Qty (pcs)	Reflow temp. ≤260°C	Reflow temp. ≤250°C		
TPB	4	105	4	105	68	3.5	2.8	1.9	B2	1100	70	0.08	27.2	4TPB68M	2000	3	3		
									D3L	2000	40	0.10	132.0	4TPB330ML	2500		2a		
	6.3	105	6.3	105	33	3.5	2.8	1.9	B2	1100	70	0.08	20.7	6TPB33M	2000		3		
										1100	70	0.08	42.8	6TPB68M	2000				
		220	105	6.3	105	68	7.3	4.3	2.8	D3L	2000	40	0.10	138.6	6TPB220ML		2500		
											1750	50	0.10	138.6	6TPB220MTL		2500		
			330	105	6.3	105	220	7.3	4.3	2.8	D3L	2000	40	0.10	207.9		6TPB330MAL	2500	
												2000	40	0.10	207.9		6TPB330ML	2500	
				470	105	6.3	105	330	7.3	4.3	3.8	D4	3000	40	0.10		207.9	6TPB330M	2000
													1850	45	0.10		207.9	6TPB330MVL	2500
		10	105	10	105	33	3.5	2.8	1.9	B2	1100	70	0.08	33.0	10TPB33M		2000	3	
											1100	70	0.08	47.0	10TPB47M		2000		
	150		105	10	105	47	7.3	4.3	2.8	D3L	2000	40	0.10	150.0	10TPB150ML		2500		
											1700	55	0.10	150.0	10TPB150MGL		2500		
	220		105	10	105	150	7.3	4.3	2.8	D3L	2000	40	0.10	220.0	10TPB220ML		2500		
											3000	40	0.10	220.0	10TPB220M		2000		
			330	105	10	105	220	7.3	4.3	3.8	D4	3000	35	0.10	330.0		10TPB330M		2000
												2800	40	0.10	330.0		10TPB330MW		2000

※1:Ripple current (100 kHz/+45 °C) ※2:ESR (100 kHz/+20 °C) ※3:tanδ (120 Hz/+20 °C) ※4:After 5 minutes
 ◆Please refer to each page in this catalog for "Reflow conditions" and "Taping specifications".
 ◆Please refer to page 42 for floor life level.

Design and specifications are each subject to change without notice. Ask factory for the current technical specifications before purchase and/or use.
 Should a safety concern arise regarding this product, please be sure to contact us immediately.

SP-Cap

Guidelines and Precautions
 Mounting specifications
 Packing specifications

Selection guide

Surface mount type

POSCAP

Guidelines and Precautions
 Mounting specifications
 Packing specifications

Line-up
 Series system diagram
 Size list
 Products list

- TPG
- TPS
- TPSF
- TQS
- TPE
- TPF
- TQC
- TA
- TV
- TH
- TPB**
- TC
- TDC
- TPC

Catalog Deletion models
 Catalog EOL models

OS-CON

Guidelines and Precautions
 Mounting specifications
 Packing specifications

Selection guide

Surface mount type

Radial lead type

Catalog EOL models

Hybrid

Guidelines and Precautions
 Mounting specifications
 Packing specifications

Selection guide

Surface mount type

Radial lead type



Guaranteed at 125 °C 1000 h

RoHS compliance, Halogen free

SP-Cap

Guidelines and Precautions
Mounting specifications
Packing specifications

Selection guide

Surface mount type

Catalog EOL models

POSCAP

Guidelines and Precautions
Mounting specifications
Packing specifications

Line-up
Series system diagram
Size list

Products list

- TPG
- TPS
- TPSF
- TQS
- TPE
- TPF
- TQC
- TA
- TV
- TH
- TPB
- TC**
- TDC
- TPC

Surface mount type

Catalog Deletion models

Catalog EOL models

OS-CON

Guidelines and Precautions
Mounting specifications
Packing specifications

Selection guide

Surface mount type

Radial lead type

Catalog EOL models

Hybrid

Guidelines and Precautions
Mounting specifications
Packing specifications

Selection guide

Surface mount type

Radial lead type

Specifications

Items	Specifications			
	B2	D2E	D3L	D4
Size code	B2	D2E	D3L	D4
Category temperature range	-55 °C to +125 °C			
Rated voltage range	2.5 V	4 V to 6.3 V	2.5 V to 10 V	
Category voltage range	2 V	3.2 V to 5 V	2 V to 8 V	
Rated capacitance range	330 μF	100 μF to 330 μF	150 μF to 680 μF	330 μF to 1000 μF
Capacitance tolerance	±20 % (120 Hz/+20 °C)			
Leakage current	Please see the attached characteristics list			
Dissipation factor(tanδ)	Please see the attached characteristics list			
Surge voltage(V)	Rated voltage x1.15			
Endurance	+125 °C, 1000 h, Category temperature range voltage applied			
	Capacitance change	Within±20 % of the initial value		
	tanδ	≤ 2 times of the initial limit		
Damp heat(Steady state)	DC leakage current	≤ 2 times of the initial limit		
	+60 °C, 90 % to 95 % RH, 500 h, No-applied voltage			
	Capacitance change	Within+50 %, -20 % of the initial value(ETCF1000M6H(5H))		
	tanδ	Within+40 %, -20 % of the initial value		
	DC leakage current	≤ 1.5 times of the initial limit		
Damp heat(Steady state)	≤ 3 times of the initial limit			

Marking and Dimensions

(B2 size)

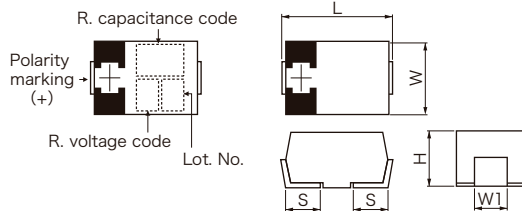

(unit : mm)

Size code	L ±0.3 ※1	W ±0.2	H ±0.2 ※2	S ±0.2	W1 ±0.1
B2	3.5	2.8	1.9	0.8	2.2
D2E	7.3	4.3	1.8	1.3	2.4
D3L	7.3	4.3	2.8	1.3	2.4
D4	7.3	4.3	3.8	1.3	2.4

※1 ±0.2 : B2 ※2 ±0.1 : B2, D2E

(D2E, D3L, D4 size)

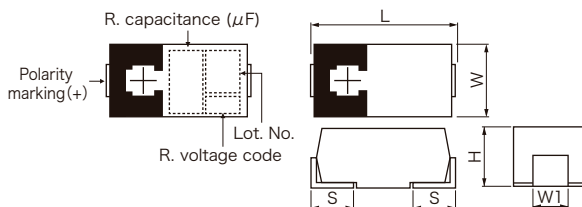

R. voltage (V)	2.5	4.0	6.3	10.0
Code	e	g	j	A

B2 size

R. cap.(μF)	330
Code	N8

Characteristics list

Series	Rated voltage (V)	Rated temp. (°C)	Category voltage (V)	Category temp. (°C)	Rated capacitance (μF)	Case size (mm)			Size code	Specifications				Standard		Floor life			
						L	W	H		Ripple current ※1 (mA rms)	ESR ※2 (mΩ max.)	tan δ ※3	LC ※4 (μA)	Part number	Min. Packaging Qty. (pcs)	Reflow temp. ≤260°C	Reflow temp. ≤250°C		
TCE	2.5	105	2	125	330	3.5	2.8	1.9	B2	3200	9/300kHz	0.08	165.0	ETCE330M9GB	2000	3	3		
						680	7.3	4.3	2.8	D3L	3500	12	0.10	170.0	ETCE680MCL			2500	
		680	7.3	4.3	2.8	D3L	3100	15	0.10	170.0	ETCE680MFL	2500							
		1000	7.3	4.3	3.8	D4	3900	15	0.15	250.0	ETCE1000MF	2000							
		4	105	3.2	125	150	7.3	4.3	1.8	D2E	2800	18	0.10	60.0	4TCE150MI			3000	
											3100	15	0.10	88.0	4TCE220MF			3000	
	220		7.3	4.3	1.8	2800	18	0.10	88.0		4TCE220MI	3000							
	220		7.3	4.3	1.8	2400	25	0.10	88.0		4TCE220M	3000							
	330		7.3	4.3	1.8	2800	18	0.10	132.0		4TCE330MI	3000							
	330		7.3	4.3	1.8	2400	25	0.10	132.0		4TCE330M	3000							
	D3L		7.3	4.3	2.8	3500	12	0.10	188.0	4TCE470MCL	2500								
			7.3	4.3	2.8	3100	15	0.10	188.0	4TCE470MFL	2500								
			7.3	4.3	2.8	2800	18	0.10	188.0	4TCE470MIL	2500								
			7.3	4.3	2.8	2400	25	0.10	188.0	4TCE470ML	2500								
			6.3	105	5	125	100	7.3	4.3	1.8	D2E	2800	18	0.10	63.0			6TCE100MI	3000
												2400	25	0.10	63.0			6TCE100M	3000
	150			7.3	4.3	1.8	3100	15	0.10	94.5		6TCE150MF	3000						
	150			7.3	4.3	1.8	2800	18	0.10	94.5		6TCE150MI	3000						
	220			7.3	4.3	1.8	2400	25	0.10	94.5		6TCE150M	3000						
	220			7.3	4.3	1.8	2800	18	0.10	138.6		6TCE220MI	3000						
	D3L			7.3	4.3	1.8	2400	25	0.10	138.6	6TCE220M	3000							
				7.3	4.3	2.8	3100	15	0.10	207.9	6TCE330MFL	2500							
		7.3		4.3	2.8	2800	18	0.10	207.9	6TCE330MIL	2500								
		7.3		4.3	2.8	2400	25	0.10	207.9	6TCE330ML	2500								
		D4		7.3	4.3	3.8	3500	18	0.15	296.1	6TCE470MI	2000							
				7.3	4.3	3.8	3000	25	0.15	296.1	6TCE470M	2000							
	680		7.3	4.3	3.8	3500	18	0.15	428.4	6TCE680MI	2000								
	680		7.3	4.3	3.8	3000	25	0.15	428.4	6TCE680M	2000								
	10		105	8	125	220	7.3	4.3	2.8	D3L	2800	18	0.10	220.0	10TCE220MIL			2500	
											2400	25	0.10	220.0	10TCE220ML			2500	
330		7.3	4.3	2.8	3000	25	0.10	330.0	10TCE330M		2000								
2.5		105	2	125	680	7.3	4.3	2.8	D3L	4400	6	0.10	170.0	ETCF680M6L	2500				
										4400	7	0.10	170.0	ETCF680M7L	2500				
		4400	10	0.10	170.0	ETCF680ML	2500												
	6100	5	0.10	170.0	ETCF680M5H	2000													
	6100	5	0.10	250.0	ETCF1000M5H	2000													
	1000	7.3	4.3	3.8	5600	6	0.10	250.0		ETCF1000M6H	2000								
	4	105	3.2	125	330	7.3	4.3	2.8	D3L	4000	12	0.10	132.0	4TCF330ML	2500				
										4400	10	0.10	188.0	4TCF470ML	2500				
		470	7.3	4.3	2.8	4400	10	0.10		272.0	4TCF680MAH	2000							
		6.3	105	5	125	220	7.3	4.3	2.8	D3L	6100	5	0.10	138.6	6TCF220M5L	2500			
											4600	9	0.10	138.6	6TCF220M9L	2500			
			330	7.3	4.3	2.8	4000	12	0.10		138.6	6TCF220ML	2500						
470	7.3		4.3	2.8	3900	9	0.10	207.9	6TCF330M9L		2500								
105	5		125	470	7.3	4.3	3.8	D4	4400		10	0.10	296.1	6TCF470MAH	2000				
105	5		125	150	7.3	4.3	2.8	D3L	3600		15	0.10	150.0	10TCF150ML	2500				

※1: Ripple current (100 kHz/ +45 °C)

※2: ESR (100 kHz/+20 °C)

※3: tanδ (120 Hz/+20 °C)

※4: After 5 minutes

◆Please refer to each page in this catalog for "Reflow conditions" and "Taping specifications".

◆Please refer to page 42 for floor life level.

SP-Cap

Guidelines and Precautions
Mounting specifications
Packing specifications

Selection guide

Surface mount type

Catalog EOL models

POSCAP

Guidelines and Precautions
Mounting specifications
Packing specifications

Selection guide
Line-up
Series system diagram
Size list
Products list

Surface mount type
TPG
TPS
TPSF
TQS
TPE
TPF
TQC
TA
TV
TH
TPB
TC
TDC
TPC

Catalog Deletion models

Catalog EOL models

OS-CON

Guidelines and Precautions
Mounting specifications
Packing specifications

Selection guide

Surface mount type

Radial lead type

Catalog EOL models

Hybrid

Guidelines and Precautions
Mounting specifications
Packing specifications

Selection guide

Surface mount type

Radial lead type



Guaranteed at 125 °C 1000 h

High voltage(25 V max.)

RoHS compliance, Halogen free

Specifications

Items	Specifications		
Size code	B2	D2	D3L
Category temperature range	-55 °C to +125 °C		
Rated voltage range	16 V to 25 V	16 V	16 V to 25 V
Category voltage range	12.8 V to 20 V	12.8 V	12.8 V to 20 V
Rated capacitance range	15 μF to 33 μF	100 μF	68 μF to 150 μF
Capacitance tolerance	±20 % (120 Hz/+20 °C)		
Leakage current	Please see the attached characteristics list		
Dissipation factor(tanδ)	Please see the attached characteristics list		
Surge voltage(V)	Rated voltage x 1.15		
Endurance	+125 °C 1000 h, category voltage applied		
	Capacitance change	Within±20 % of the initial value	
	tanδ	≤ 2 times of the initial limit	
	DC leakage current	≤ 2 times of the initial limit	
Damp heat(Steady state)	+60 °C, 90 % to 95 % RH, 500 h, No-applied voltage		
	Capacitance change	Within+40 %, -20 % of the initial value	
	tanδ	≤ 1.5 times of the initial limit	
	DC leakage current	≤ 3 times of the initial limit	

Marking and Dimensions

(B2 size)

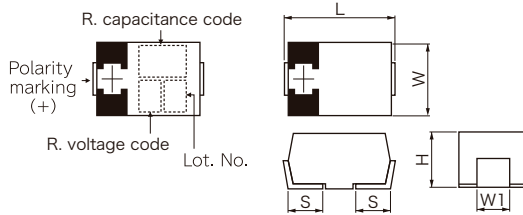

Size code	L	W ±0.2	H	S ±0.2	W1 ±0.1
B2	3.5±0.2	2.8	1.9±0.1	0.8	2.2
D2	7.3±0.2	4.3	1.9±0.1	1.3	2.4
D3L	7.3±0.3	4.3	2.8±0.2	1.3	2.4

B2 size

R. voltage (V)	16	20	25
Code	C	D	E

(D2, D3L size)

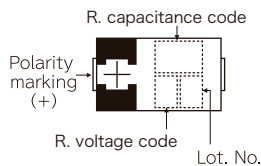

D2, D3L size

R. voltage (V)	16	20	25
Code	C	D	1E

B2 size

R. cap. (μF)	15	22	33
Code	E7	J7	N7

Characteristics list

Series	Rated voltage (V)	Rated temp. (°C)	Category voltage (V)	Category temp. (°C)	Rated capacitance (μF)	Case size (mm)			Size code	Specifications				Standard		Floor life	
						L	W	H		Ripple current ※1 (mA rms)	ESR ※2 (mΩ max.)	tan δ ※3	LC ※4 (μA)	Part number	Min. Packaging Qty (pcs)	Reflow temp. ≤260°C	Reflow temp. ≤250°C
TDC	16	105	12.8	125	33	3.5	2.8	1.9	B2	1000	90	0.10	158.4	16TDC33MYFB	2000	-	3
		105	12.8	125	100	7.3	4.3	1.9	D2	1800	50	0.10	160.0	16TDC100MYF	3000		
		105	12.8	125	150	7.3	4.3	2.8	D3L	1800	50	0.10	240.0	16TDC150MYF	2500		
	20	105	16	125	22	3.5	2.8	1.9	B2	1000	90	0.10	132.0	20TDC22MYFB	2000		
		105	16	125	100	7.3	4.3	2.8	D3L	1700	55	0.10	200.0	20TDC100MYF	2500		
		25	105	20	125	15	3.5	2.8	1.9	B2	900	100	0.10	112.5	25TDC15MYFB		
105	20		125	68	7.3	4.3	2.8	D3L	1400	70	0.10	170.0	25TDC68MYF	2500			

※1: Ripple current (100 kHz/ +105 °C) ※2: ESR (100 kHz/+20 °C) ※3: tanδ (120 Hz/+20 °C) ※4: After 5 minutes

◆Please refer to each page in this catalog for "Reflow conditions" and "Taping specifications".

◆Please refer to page 42 for floor life level.



Low profile (Height 1.1 mm)

RoHS compliance, Halogen free

Specifications

Items	Specifications	
	B1	D2
Size code	B1	D2
Category temperature range	-55 °C to +105 °C	
Rated voltage range	6.3 V to 12.5 V	6.3 V to 10 V
Category voltage range	5 V to 10 V	6.3 V to 10 V
Rated capacitance range	10 μF to 47 μF	68 μF to 330 μF
Capacitance tolerance	±20 % (120 Hz/+20 °C)	
Leakage current	Please see the attached characteristics list	
Dissipation factor (tan δ)	Please see the attached characteristics list	
Surge voltage (V)	Rated voltage x 1.15	
Endurance	+105 °C 2000 h, (B1 size: 1000 h) rated voltage applied *Rated temp. 85 °C 1000 h rated voltage applied	
	Capacitance change	Within ±20 % of the initial value
	tan δ	≤ 1.5 times of the initial limit
	DC leakage current	Within the initial limit
Damp heat (Steady state)	+60 °C, 90 % to 95 % RH, 500 h, No-applied voltage	
	Capacitance change	Within +40 %, -20 % of the initial value
	tan δ	≤ 1.5 times of the initial limit
	DC leakage current	≤ 3 times of the initial limit

Marking and Dimensions

<B1 size>

R. capacitance code
Polarity marking (+)
R. voltage code
Lot. No.

<D2 size>

R. capacitance (μF)
Polarity marking (+)
R. voltage code
Lot. No.

(unit : mm)

Size code	L ±0.2	W ±0.2	H ±0.1	S ±0.2	W1 ±0.1
B1	3.5	2.8	1.1	0.8	2.2
D2	7.3	4.3	1.9	1.3	2.4

R. voltage (V)	6.3	8.0	10.0	12.5
Code	j	k	A	B

B1 size

R. cap. (μF)	10	15	22	33	47
Code	A7	E7	J7	N7	S7

Characteristics list

Series	Rated voltage (V)	Rated temp. (°C)	Category voltage (V)	Category temp. (°C)	Rated capacitance (μF)	Case size (mm)			Size code	Specifications				Standard		Floor life	
						L	W	H		Ripple current ※1 (mA rms)	ESR ※2 (mΩ max)	tan δ ※3	LC ※4 (μA)	Part number	Min. Packaging Qty (pcs)	Reflow temp. ≤260°C	Reflow temp. ≤250°C
TPC	6.3	85	5	105	47	3.5	2.8	1.1	B1	1100	55	0.10	29.6	6TPC47M	3000	3	
						3.5	2.8	1.1		1000	70	0.10	29.6	6TPC47MB			
		105	6.3	105	100	7.3	4.3	1.9	D2	1700	45	0.10	63.0	6TPC100M	3000		
						7.3	4.3	1.9		1900	40	0.10	94.5	6TPC150M			
		85	5	105	330	7.3	4.3	1.9	D2	1900	40	0.10	207.9	6TPC330MA	3000		
						7.3	4.3	1.9		1900	40	0.10	207.9	6TPC330MA			
	8	85	6.3	105	22	3.5	2.8	1.1	B1	1000	70	0.10	17.6	8TPC22M	3000	3	
						7.3	4.3	1.9		1900	40	0.10	120.0	8TPC150M			
		105	8	105	150	7.3	4.3	1.9	D2	1700	45	0.10	68.0	10TPC68M	3000		
						7.3	4.3	1.9		1450	60	0.10	68.0	10TPC68MM			
		105	10	105	68	7.3	4.3	1.9	D2	1100	100	0.10	68.0	10TPC68ME	3000		
						7.3	4.3	1.9		1700	45	0.10	100	10TPC100M			
	105	10	105	100	7.3	4.3	1.9	D2	1600	50	0.10	100	10TPC100MT	3000			
					7.3	4.3	1.9		1500	55	0.10	100	10TPC100MG				
	12.5	85	10	105	100	7.3	2.8	1.1	B1	800	80	0.10	12.5	12TPC10M	3000	3	
						7.3	2.8	1.1		800	80	0.10	18.8	12TPC15M			

※1: Ripple current (100 kHz/+45 °C) ※2: ESR (100 kHz/+20 °C) ※3: tan δ (120 Hz/+20 °C) ※4: After 5 minutes

◆Please refer to each page in this catalog for "Reflow conditions" and "Taping specifications".

◆Please refer to page 42 for floor life level.

Design and specifications are each subject to change without notice. Ask factory for the current technical specifications before purchase and/or use.

Should a safety concern arise regarding this product, please be sure to contact us immediately.

SP-Cap

Guidelines and Precautions
Mounting specifications
Packing specifications

Selection guide

Surface mount type

POSCAP

Guidelines and Precautions
Mounting specifications
Packing specifications

Line-up
Series system diagram
Size list
Products list

- TPG
- TPS
- TPSF
- TQS
- TPE
- TPF
- TQC
- TA
- TV
- TH
- TPB
- TC
- TDC
- TPC

Catalog Deletion models

Catalog EOL models

OS-CON

Guidelines and Precautions
Mounting specifications
Packing specifications

Selection guide

Surface mount type

Radial lead type

Catalog EOL models

Hybrid

Guidelines and Precautions
Mounting specifications
Packing specifications

Selection guide

Surface mount type

Radial lead type

Catalog deletion models

The following table is a list of our items which have been deleted from our catalogs. If you are using any of the following models on the deleted list, please substitute them with the suggested alternative model as soon as possible. Our company continue to supply them to customers who have already used them, for the time being.

Series	Size code	Models for deletion	Year of deletion	Alternative model	Series	Size code	Models for deletion	Year of deletion	Alternative model	
TPB	B2	2R5TPB100M	2012	4TPE100MZB	TPG	B1G	10TPG33M	2011	12TPG33M	
		2R5TPB220MA	2009	2R5TPE220MZB			2R5TPG220M	2021	ETPS220MUD	
		4TPB100M	2009	4TPE100MZB			6TPG100M	2021	6TPS150MUD	
		8TPB47M	2009	10TPB47M			6TPG100MG	2021	6TPS150MUD	
		6TPB47M	2009	6TPC47MB			6TPG100MZGD	2021	6TPS150MUD	
		6TPB100MA	2009	6TPE100MAZB			8TPG47M	2021	10TPG47M	
		6TPB100MAV	2009	6TPE100MAZB			2R5TPG220MUG	2021	ETPS220MUD	
	D3L	2R5TPB330ML	2009	2R5TPE330M		B15G	4TPG220M	2021	4TPS220MUD	
		4TPB220ML	2009	4TPE220M			6TPG150M	2021	6TPS150MUD	
		4TPB470ML	2009	4TPE470ML			6TPG150MZG	2021	6TPS150MUD	
		6TPB150ML	2009	6TPC150M						
		10TPB100ML	2010	10TPC100M						
		4TPB220M	2008	4TPE220M						
	D3	6TPB150M	2008	6TPC150M		TPSF	B2S	11TPSF62MAIG	2012	-
		10TPB100M	2008	10TPC100M	D2		4THC220M	2013	4THE220M	
		2R5TPB680M	2009	2R5TPE680MFL	TH		D3L	2R5THB330ML	2010	-
		2R5TPB1000M	2009	2R5TPE1000MF		D4	4THB680M	2013	-	
	D4	4TPB470M	2009	4TPE470ML	TQC	C	16TQC22M	2011	25TQC22MYFD	
		4TPB680M	2009	6TPE680MI			20TQC15M	2011	25TQC15MYFD	
		2R5TPC56M	2012	6TPB68M			25TQC10M	2011	25TQC15MYFD	
	4TPC47M	2012	6TPC47MB	16TQC33M			2012	16TQC33MYFD		
	6TPC33M	2012	6TPC47MB	16TQC47M			2012	16TQC47MYFD		
	10TPC33MB	2013	12TPG33M	16TQC68MY			2012	16TQC68MYF		
	2R5TPC330M	2009	2R5TPE330M	20TQC22M			2012	25TQC22MYFD		
D2	4TPC150M	2009	4TPE150MI	D2		20TQC22MYFD	2015	25TQC22MYFD		
	4TPC220M	2009	4TPE220M			20TQC47MY	2012	20TQC47MYF		
	2TPE330MIB	2011	2TPE330MFB			25TQC15M	2012	25TQC15MYFD		
TPC	B1	2TPE330MAFGB	2011			2TPE330MAFB	D3L	16TQC68M	2012	16TQC68MYF
		2TPE330MFB	2021			ETPE330MFB		20TQC47M	2012	20TQC47MYF
		2TPE330MFB	2021			ETPE330MFB		25TQC33M	2012	25TQC33MYF
	2TPE330MADGB	2021	ETPE330M9GB			D3		16TQC100M	2012	16TQC100MYF
	2R5TPE150MZB	2011	2R5TPE220MZB	TQS	B1S			16TQS33MBD	2020	-
	2R5TPE220MIB	2012	2R5TPE220MFGB					25TQS10MED	2020	-
	ETPE330MAFB	2021	ETPE330MFB			35TQS6R8MHD		2020	-	
	TPE	B2	4TPE150MUB	2013	4TPE150MAZB					
			2R5TPE220MC	2012	2R5TPE220M9					
			2R5TPE220M7	2012	2R5TPE330M7					
2R5TPE470M			2011	2R5TPE470MI						
4TPE150M			2011	4TPE150MI						
D3L			2R5TPE680ML	2012	2R5TPE680MFL					
			2R5TPE680MIL	2011	2R5TPE680MFL					
		6TPE330MAL	2021	6TPE330ML						
D4		2R5TPE1000M	2011	2R5TPE1000MF						
		2R5TPE1000MI	2012	2R5TPE1000MF						
		4TPE680M	2011	6TPE680MI						
		4TPE680MI	2012	6TPE680MI						
			4TPE680MF	2012	4TPF680MAH					

SP-Cap

Guidelines and Precautions
Mounting specifications
Packing specifications

Selection guide

Surface mount type

Catalog EOL models

POSCAP

Guidelines and Precautions
Mounting specifications
Packing specifications

Line-up
Series system diagram
Size list
Selection guide

Products list

- TPG
- TPS
- TPSF
- TQS
- TPE
- TPF
- TQC
- TA
- TV
- TH
- TPB
- TC
- TDC
- TPC

Surface mount type

Catalog Deletion models
Catalog EOL models

OS-CON

Guidelines and Precautions
Mounting specifications
Packing specifications

Selection guide

Surface mount type

Radial lead type

Catalog EOL models

Hybrid

Guidelines and Precautions
Mounting specifications
Packing specifications

Selection guide

Surface mount type

Radial lead type

Catalog EOL models

The following table is a list of the End-Of-Life (EOL) models. Sales of these items will end as soon as we run out of its stock. We would like to express our appreciation for your business over the years with these products and we hope the new, alternative parts will continue to serve your needs. Thank you very much.

Series	Size code	Models for deletion	Year of deletion	Alternative model	Series	Size code	Models for deletion	Year of deletion	Alternative model
TPA	C	6TPA47M	2012/9	10TPB47M	TPE	B2	2R5TPE220MPB	2012/9	2R5TPE220MLB
		10TPA33M	2012/9	10TPB33M			2R5TPE220MDGB	2013	2R5TPE220MFGB
	D3	4TPA220M	2012/9	4TPE220M		2R5TPE330MFC2	2012/9	2R5TPE330MF	
		6TPA150M	2012/9	6TPC150M		2R5TPE330MIC2	2012/9	2R5TPE330MF	
TPB	B2	10TPA100M	2012/9	10TPC100M		C2	2R5TPE330MCC2	2012/9	2R5TPE330MC
		4TPB100MV	2012/9	4TPE100MZB			2R5TPE330M9C2	2012/9	2R5TPE330M9
		4TPB150MA	2012/9	4TPE150MAZB			4TPE220MFC2	2012/9	4TPE220MF
		8TPB33M	2012/9	10TPB33M			4TPE220MIC2	2012/9	4TPE220MI
	C	2R5TPB220MC	2012/9	4TPE220MI		4TPE220MPC2	2012/9	4TPE220MI	
		4TPB150MC	2012/9	6TPE150M		6TPE150MIC2	2012/9	6TPE150MI	
		4TPB220MC	2012/9	4TPE220MI		6TPE150MPC2	2012/9	6TPE150M	
		6TPB100MC	2012/9	6TPC100MG		8TPE100MPC2	2012/9	10TPPF150ML	
		6TPB150MC	2012/9	6TPE150M		2R5TPE330MFC	2012/9	2R5TPE330MF	
		8TPB82MC	2012/9	8TPE100MAZB		2R5TPE330MIC	2012/9	2R5TPE330MF	
	D3L	10TPB47MC	2012/9	10TPC68M		2R5TPE330MPC	2012/9	2R5TPE330MF	
		10TPB68MC	2012/9	10TPC68M		4TPE220MIC	2012/9	4TPE220MI	
10TPB220MC		2009/10	–	4TPE220MPC	2012/9	4TPE220MI			
2R5TPB470ML		2012/9	2R5TPE470MI	6TPE150MPC	2012/9	6TPE150M			
D3	2R5TPB680ML	2012/9	2R5TPE680MFL	6TPE220MIC	2012/9	6TPE220MI			
	16TPB47ML	2003/6	16TQC47MYFD	6TPE220MPC	2012/9	6TPE220M			
TPC	C1	2R5TPB330M	2012/9	2R5TPE330M	D2E	10TPE150MGC	2012/9	10TPE220ML	
		16TPB47M	2003/6	16TQC47MYFD		10TPE180MGC	2012/9	10TPE220ML	
		2R5TPC82M	2012/9	–		2TPE330M6	2011	2TPF330M6	
		4TPC56M	2012/9	–		2TPE330M7	2011	2R5TPE330M7	
	D2	4TPC100M	2012/9	6TPG100MG	2TPE330M9	2011	2R5TPE330M9		
		6TPC68M	2012/9	6TPG100MG	2TPE470M6	2011	2R5TPF470M6L		
		6TPC100MC	2012/9	6TPG100MG	2TPE470M7	2011	2R5TPE470M7		
		8TPC33M	2012/9	12TPG33M	2TPE470M9	2011	2R5TPE470M9		
TPD	D4D	2R5TPD470M	2007/10	2R5TPF470ML	D3L	2TPF470M6	2012/9	2R5TPF470M6L	
		2R5TPD470M5	2012/3	ETPF470M5H		4TPF470M5EL	2014	–	
		2R5TPD470M6	2012/3	2R5TPF470M6L	6TPF330M5EL	2014	–		
		2R5TPD470M8	2007/10	2R5TPF470M7L	TPG	B1G	4TPG150M	2012/9	6TPG150M
		2R5TPD680M	2007/10	2R5TPF680ML		B15G	6TPG68MG	2012/9	6TPG100M
		2R5TPD680M5	2012/3	ETPF680M5H	TPL	D2T	2R5TPL220MC	2012/9	–
		2R5TPD680M6	2012/3	2R5TPF680M6L			2R5TPL330M7	2011/7	–
		2R5TPD680M8	2007/10	2R5TPF680M7L		All models	2013	–	
		2R5TPD1000M	2012/3	ETPF1000M6H		D12T	All models	2013	–
		2R5TPD1000M8	2012/3	ETPF1000M6H	D15T	All models	2013	–	
		2R5TPD1000M6	2012/3	ETPF1000M6H	TPLF	D2T	2TPLF470M7	2012/9	–
		2R5TPD1000M5	2012/3	ETPF1000M5H			2TPLF560M6	2011/7	–
	4TPD330M	2007/10	4TPF330ML	TPSF	B2S	All models	2013	–	
	4TPD470M	2007/10	4TPF470ML			2TPSF270MC	2012/9	2TPSF270M9G	
	4TPD680M	2012/3	4TPF680MAH	TH	B1S	2TPSF270M9	2012/9	2TPSF270M9G	
	6TPD220M	2007/10	6TPF220ML			D3L	ETPSF200M9ED	2014	–
6TPD330M	2007/10	6TPF330M9L	D4	2R5THB470ML	2012/9	6THB470M			
6TPD470M	2012/3	6TPF470MAH		2R5THB680M	2012/9	–			
10TPD150M	2007/10	10TPF150ML		2R5THB1000M	2012/9	–			
TPU	S08	2R5TPU22M	2012/9	–	D4D	2R5THD680M	2012/3	2R5TPF680M6L	
		4TPU15M	2012/9	–		4THD470M	2012/9	–	
		6TPU10M	2012/9	–		6THD330M	2012/3	6TPF330M9L	
	S09	2R5TPU22MSI	2011	–	TR	TR series	–	TA series	
		2R5TPU47MSI	2018	–		APA	D2A	APA series	2006/4
		ETPU100MSI	2018	–	APB	D1	APB series	2006/4	–
		4TPU15MSI	2011	–	APC	D2	APC series	2009/6	–
		4TPU33MSI	2011	–	APD	D1	APD series	2009/6	–
		4TPU68MSI	2018	–	TQC	B15	35TQC2R7MYF	2016	35TQS6R8MHD
		6TPU10MSI	2018	–			ETPH100MHA	2018	–
		6TPU22MSI	2018	–	A09	4TPH68MHA	2018	–	
	6TPU47MSI	2018	–	6TPH47MHA		2018	–		
10TPU4R7MSI	2018	–	6TPH100MAEA	2018		–			
2R5TPU47MSK	2012/9	–	ATPH33MAHA	2018		–			
2R5TPU68MSK	2013	–	ETPH220MABC	2018		–			
4TPU33MSK	2012/9	–	ETPH220MAZC	2013		–			
4TPU47MSK	2013	–	A14	4TPH150MABC	2018	–			
6TPU22MSK	2012/9	–		6TPH100MABC	2018	–			
6TPU33MSK	2013	–	TPH	A09	2R5TPU100MAI	2011	–		
4TPU68MAI	2011	–			4TPU68MAI	2011	–		
6TPU47MAI	2011	–			6TPU47MAI	2011	–		
10TPU33MAI	2011	–			10TPU33MAI	2011	–		
4TPU68MBI	2012/9	–			4TPU47MB	2012/9	–		
6TPU47MB	2012/9	–			6TPU150MBI	2018	–		
6TPU150MBI	2018	–	8TPU33MBI	2012/9	–				
8TPU33MBI	2012/9	–							

SP-Cap

Guidelines and Precautions
Mounting specifications
Packing specifications

Selection guide

Surface mount type

Catalog EOL models

POSCAP

Guidelines and Precautions
Mounting specifications
Packing specifications

Selection guide
Line-up
Series system diagram
Size list
Products list

- TPG
- TPS
- TPSF
- TQS
- TPE
- TPF
- TQC
- TA
- TV
- TH
- TPB
- TC
- TDC
- TPC

Surface mount type

Catalog Deletion models

Catalog EOL models

OS-CON

Guidelines and Precautions
Mounting specifications
Packing specifications

Selection guide

Surface mount type

Radial lead type

Catalog EOL models

Hybrid

Guidelines and Precautions
Mounting specifications
Packing specifications

Selection guide

Surface mount type

Radial lead type

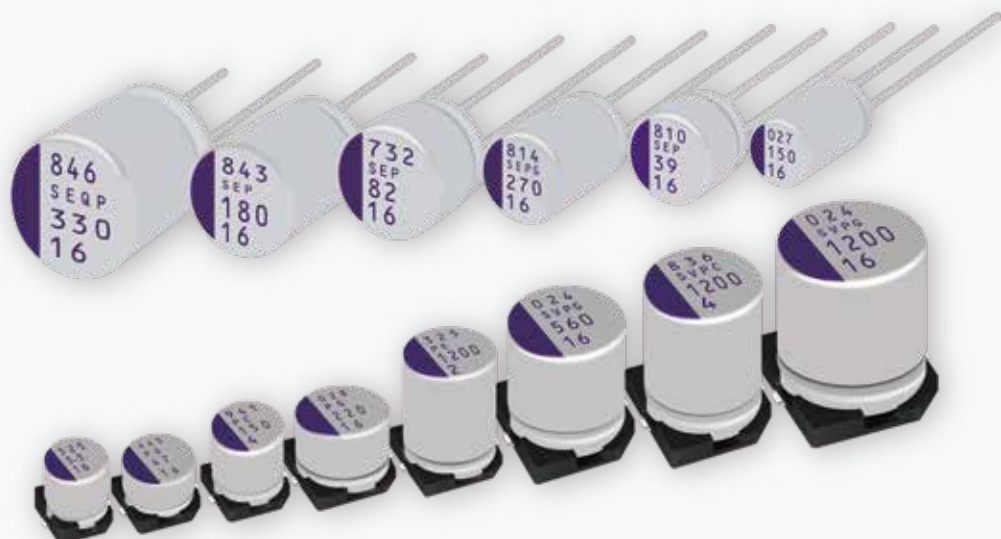

Conductive Polymer Aluminum Solid Capacitors

OS-CON™

INDEX

Guidelines and Precautions	P 75
Mounting specifications / Packing specifications	P 78
Selection guide	P 81
Products list	P 87
Catalog EOL models	P119

SP-Cap

Guidelines and Precaution
Mounting specifications
Packing specifications

Selection guide

Surface mount type

POSCAP

Guidelines and Precautions
Mounting specifications
Packing specifications

Selection guide

Surface mount type

Catalog Deletion models
Catalog EOL models

OS-CON

Guidelines and Precautions
Mounting specifications
Packing specifications

Selection guide
Line-up
Series system diagram
Size list

Products list

- SVT
- SVPT
- SVF
- SVPK
- SXV
- SVPG
- SVPF
- SVPA
- SVPC
- SVPB
- SVPD
- SVPS
- SVPE
- SVQP
- SVP
- SEK
- SEF
- SEPG
- SXE
- SEPF
- SEPC
- SEQP
- SEP

Catalog EOL models

Hybrid

Guidelines and Precautions
Mounting specifications
Packing specifications

Selection guide

Surface mount type

Radial lead type

Applications

Main market

Desktop computer



Audio / Visual

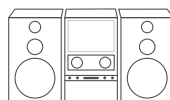

Server

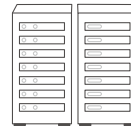

Communications infrastructure

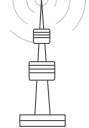

Industrial equipment

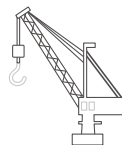

Industrial robot

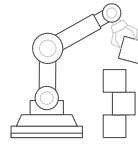

Home appliance



Guidelines and Precautions

SP-Cap

Guidelines and Precautions
Mounting specifications
Packing specifications

Selection guide

Surface mount type

Catalog EOL models

POSCAP

Guidelines and Precautions
Mounting specifications
Packing specifications

Selection guide

Surface mount type

Catalog Deletion models

Catalog EOL models

OS-CON

Guidelines and Precautions
Mounting specifications
Packing specifications

Line-up
Series system diagram
Size list

Products list

SVT	Surface mount type
SVPT	
SVF	
SVPK	
SXV	
SVPG	
SVPF	
SVPA	
SVPC	
SVPB	
SVPD	
SVPS	
SVPE	
SVQP	
SVP	
SEK	Radial lead type
SEF	
SEPG	
SXE	
SEPF	
SEPC	
SEQP	
SEP	

Catalog EOL models

Hybrid

Guidelines and Precautions
Mounting specifications
Packing specifications

Selection guide

Surface mount type

Radial lead type



Application Guidelines

1. Circuit design

1-1 Prohibited circuits

(a) Leakage current of the **OS-CON** may increase in the following conditions.

- (1) Soldering
- (2) When voltage is not applied: high temperature no-load test, high temperature and high humidity no-load test, rapidly changing temperature test, etc.

(b) Avoid the use of the **OS-CON** in the following type of circuits because leakage current may increase.

- (1) High-impedance circuits
- (2) Coupling circuits
- (3) Time constant circuits
- (4) Other circuits that are significantly affected by leakage current

※ If you plan to use 2 or more **OS-CONs** in a series connection, please contact us before use

1-2 Failure and life-span

The failure rate is 0.5 % /1000 h (Confidence level: 60 %) based on JIS C 5003.

The prospective failure is not zero. The main failure modes are as follows.

1-2-1 Contingency failure

The most common failure mode is a short circuit. Mainly caused by the soldering or operating temperature environment, along with heat stresses, electrical stresses or mechanical stresses as follows.

- Applying voltage over the rated voltage.
- Applying reverse voltage
- Excessive mechanical stress
- Applying rush current by sudden charge or discharge out of the specification.

(a) The following phenomenon is seen when short-current is applied to the **OS-CON**.

(1) When current is relatively low (ϕ 10: approx 1 A or less, ϕ 8: approx 0.5 A or less, ϕ 6.3: approx 0.2 A or less) The **OS-CON** becomes heated, but no effects are visible even when the current is continuously carried.

(2) When the short circuit currents exceed the mentioned value above.
After internal temperature increase, sealing rubber may be turned over.
In some cases, odorous gas may be produced.

(b) In case a short circuit occurs, ensure safety by fully considering the followings.

- (1) If odorous gas is released, turn off the main power of the equipment.
In this case, keep your face and hands away from the area.
- (2) Though it depends on the conditions, it takes seconds to minutes before odorant gas generates.
Protective circuit should operate in this period.
- (3) If the gas comes into eyes, rinse immediately. If the gas is inhaled, gargle immediately.
- (4) Do not lick the electrolyte. If the electrolyte touches skin, wash it off with soap immediately.
- (5) The **OS-CON** contains combustible substances. In case a large current continues to flow after a short circuit, in the worst case, the shorted-out section may ignite. For safety, install a redundant circuit or a protective circuit, etc.

1-2-2 Wear-out failure (life time)

When life time span exceeded the specified guarantee time of endurance and damp heat, electrolyte might insulate and cause electric characteristic changed. This is called an open circuit.

The electric characteristics of capacitance and ESR may possibly change within the specified range in specifications even if it is used under the condition of the rated voltage, electric and mechanical performance. Please note it when designing.

1-3 Leakage current

Mechanical stress may cause **OS-CON**'s leakage current increased.

In such a case, leakage current will gradually decrease by applying voltage (within the category voltage and the upper limit of category temperature).

1-4 Rapid charge and discharge limitation

Allowance of a large rush current to flow due to rapid charge and discharge may result in short circuit or large leakage current. The protection circuit, to maintain high reliability, is recommended when rush current to flow to the **OS-CON** is in the following cases.

- (a) Products which 10 times of allowable ripple current is less than 10 A: It is when 10 A or over of rush current is applied.
- (b) Products which 10 times of allowable ripple current is 10 A or over: It is when rush current, which the figure is over 10 times of allowable ripple current, is applied.

2. Mounting

2-1 Soldering with a soldering iron

- (a) When lead terminals for radial lead type must be processed because the lead pitch and the PCB holes do not match, process them without any stresses to the **OS-CON** before soldering.
- (b) Solder without any excessive stresses to the **OS-CON** itself.
- (c) When the **OS-CON** has been soldered once and needs to be removed, remove it after the solder has been completely melted.
- (d) Do not let the tip of the soldering iron touch (a) the **OS-CON** itself.

2-2 Flow soldering

- (a) Do not apply flow soldering to **OS-CON** SMD type.
- (b) Do not solder the **OS-CON** itself by submerging it in melted solder.
- (c) Solder the opposite side that the **OS-CON** is mounted on.
- (d) Note that flux does not adhere to anywhere except the lead terminal.
- (e) Note that other components do not fall over and touch the **OS-CON** when soldering.

2-3 Reflow soldering

- (a) Do not apply reflow soldering to **OS-CON** Radial Lead type.
- (b) Please contact us for setting VPS conditions.

2-4 Capacitor handling after soldering

Do not subject the **OS-CON** to excessive stress as follows.

- (a) Do not tilt, bend or twist the **OS-CON**.
- (b) Do not move the PCB with holding the **OS-CON** itself.
- (c) Do not hit the **OS-CON** with objects.
- (d) When stacking PCBs, make sure that the **OS-CON** does not touch other PCBs or components.

2-5 Circuit board cleaning

Check the following items before washing PC board with these detergents: high quality alcohol-based cleaning fluid such as Pine- α ST-100S, clean thru 750H, 750L, 710M, 750K or Techno Care FRW 14 through 17 or detergents including substitute freon as AK-225AES or IPA.

- (a) Use immersion or ultrasonic waves to clean within 2 minutes.
- (b) The temperature of the cleaning fluid should be less than 60 °C.
- (c) Watch the contamination of the detergent (a) such as conductivity, pH, specific gravity, water content, etc.
- (d) Do not store the **OS-CON** in a location subject to gases from the cleaning fluid or in an airtight container after cleaning.
- (e) Dry the PCB or **OS-CON** with hot air that should be less than the upper category temperature.
- (f) Please note that indication may disappear when rubbing print side after washing depending on a cleaner.
- (g) Please contact us for details about detergents, cleaning methods and detergents other than those listed above.

2-6 Fixatives and coating materials

- (a) Select the appropriate covering and sealant materials for the **OS-CON**. In particular, don't use acetone in the fixative, coating agent and diluent.
- (b) Before applying the fixative or coating, completely remove any flux residue and foreign matter from the area where the board and the **OS-CON** will be jointed together.
- (c) Allow any detergent to dry before applying the fixative or coating.
- (d) Please contact us for the fixative and coating heat curing conditions.

2-7 Capacitor insulation

Be sure to completely separate the case, negative lead terminal, positive lead terminal and PC board patterns with each other due to the following reasons.

- (a) Insulation is not guaranteed at a part of resin on the surface of a case.
- (b) It offers inconstant resistance between a case and a negative lead terminal and it isn't insulated.

SP-Cap

Guidelines and Precautions
Mounting specifications
Packing specifications

Selection guide

Surface mount type

Catalog EOL models

POSCAP

Guidelines and Precautions
Mounting specifications
Packing specifications

Selection guide

Surface mount type

Catalog Deletion models

Catalog EOL models

OS-CON

Guidelines and Precautions

Mounting specifications

Packing specifications

Selection guide	Line-up
	Series system diagram Size list
Surface mount type	Products list
	SVT
	SVPT
	SVF
	SVPK
	SXV
	SVPG
	SVPF
	SVPA
	SVPC
	SVPB
	SVPD
	SVPS
	SVPE
	SVQP
	SVP
Radial lead type	SEK
	SEF
	SEPG
	SXE
	SEPF
	SEPC
SEQP	
SEP	

Catalog EOL models

Hybrid

Guidelines and Precautions

Mounting specifications

Packing specifications

Selection guide

Surface mount type

Radial lead type

Guidelines and Precautions

SP-Cap

Guidelines and Precautions
Mounting specifications
Packing specifications

Selection guide

Surface mount type

Catalog EOL models

POSCAP

Guidelines and Precautions
Mounting specifications
Packing specifications

Selection guide

Surface mount type

Catalog Deletion models

Catalog EOL models

OS-CON

Guidelines and Precautions
Mounting specifications
Packing specifications

Line-up
Series system diagram
Size list
Selection guide

Products list

SVT	Surface mount type
SVPT	
SVF	
SVPK	
SXV	
SVPG	
SVPF	
SVPA	
SVPC	
SVPB	
SVPD	
SVPS	
SVPE	
SVQP	
SVP	
SEK	Radial lead type
SEF	
SEPG	
SXE	
SEPF	
SEPC	
SEQP	
SEP	

Catalog EOL models

Hybrid

Guidelines and Precautions
Mounting specifications
Packing specifications

Selection guide

Surface mount type

Radial lead type

3.Storage

Open the bags just before mounting and use up all products once opened,
For keeping a good solderability, store the OS-CON as follows.

※ Due to the feature of the plating material of the lead terminal, it may rarely become dull color during the specified period as follow, but it will not affect the solderability.

		Before unsealing	After unsealing
Radial lead type	Bag packing product	Within 30 months after shipment	Within 7 days from opening
	Taping product	Within 24 months after shipment	
SMD type※1		Within 24 months after shipment	Within 30 days from opening (packaged with carrier tape)

※1 The JEDEC J-STD-020 standard is not applicable

Intellectual property right

We, Panasonic Group are providing the product and service that customers can use without anxiety, and are working positively on the protection of our products under intellectual property rights.
Representative patents relating to OS-CON are as follows:

US Patent No. 7158367

Mounting specifications

Recommendable reflow soldering (Surface mount type)

Peak temperature 250 °C lead free reflow soldering profile

The cycles of reflow soldering: 2 max.

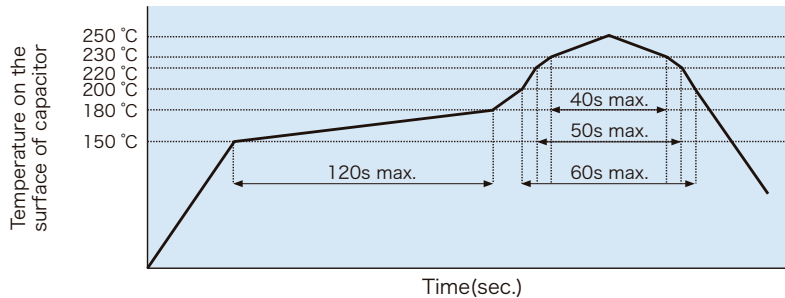

Peak temperature 260 °C lead free reflow soldering profile

The cycles of reflow soldering: 1 max.

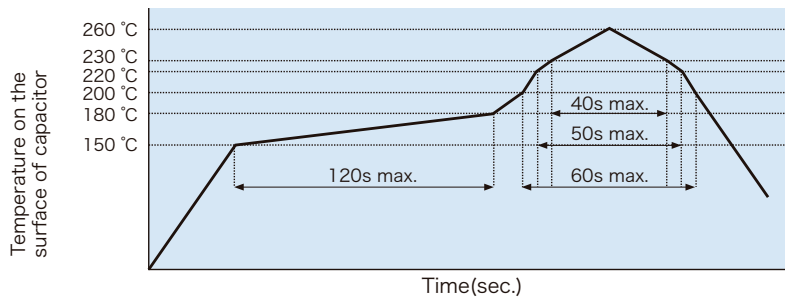

Flow soldering (Radial lead type)

	Temperature	Time	Flow number
Preheating	120 °C or less (ambient temperature)	120 sec. or less	1 time
Soldering condition	260 °C + 5 °C or less	10 + 1 sec. or less	2 times or less ※1

※1. When soldering 2 times, total immersion time should be 10 + 1 sec. or less.

Soldering with a soldering iron

Tip of a soldering iron: 400±10 °C
Working time: 5 sec. max

Land/Pad Pattern

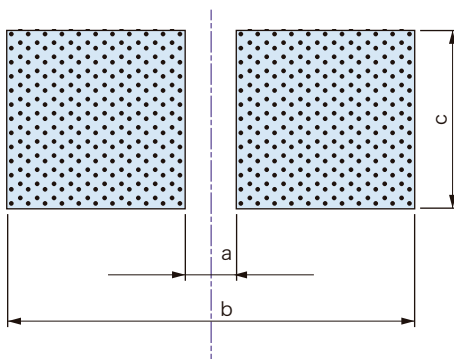

Size code	a	b	c
A5	1.0	6.2	1.6
B45	1.4	7.4	1.6
B6	1.4	7.4	1.6
C5	2.1	9.1	1.6
C55	2.1	9.1	1.6
C6	2.1	9.1	1.6
C65	2.1	9.1	1.6
C8	2.1	9.1	1.6
C10	2.1	9.1	1.6
C10L	2.1	9.1	2.5
E7	2.8	11.1	1.9
E10	2.8	11.1	1.9
E12	2.8	11.1	1.9
F8	4.3	13.1	1.9
F10	4.3	13.1	1.9
F12	4.3	13.1	1.9

(unit : mm)

SP-Cap

Guidelines and Precaution
Mounting specifications
Packing specifications

Selection guide

Surface mount type

Catalog EOL models

POSCAP

Guidelines and Precautions
Mounting specifications
Packing specifications

Selection guide

Surface mount type

Catalog Deletion models

Catalog EOL models

OS-CON

Guidelines and Precautions
Mounting specifications
Packing specifications

Selection guide
Line-up
Series system diagram
Size list

Products list

SVT
SVPT
SVF
SVPK
SXV
SVPG
SVPF
SVPA
SVPC
SVPB
SVPD
SVP5
SVPE
SVQP
SVP
SEK
SEF
SEPG
SXE
SEPF
SEPC
SEQP
SEP

Surface mount type

Radial lead type

Catalog EOL models

Hybrid

Guidelines and Precautions
Mounting specifications
Packing specifications

Selection guide

Surface mount type

Radial lead type

Packing specifications

SP-Cap

SMD type

Guidelines and Precautions
Mounting specifications
Packing specifications

Selection guide

Surface mount type

Catalog EOL models

POSCAP

Guidelines and Precautions
Mounting specifications
Packing specifications

Selection guide

Surface mount type

Catalog Deletion models

Catalog EOL models

OS-CON

Guidelines and Precautions
Mounting specifications
Packing specifications

Line-up

Series system diagram
Size list

Products list

SVT

SVPT

SVF

SVPK

SXV

SVPG

SVPF

SVPA

SVPC

SVPB

SVPD

SVPS

SVPE

SVQP

SVP

SEK

SEF

SEPG

SXE

SEPF

SEPC

SEQP

SEP

Catalog EOL models

Hybrid

Guidelines and Precautions
Mounting specifications
Packing specifications

Selection guide

Surface mount type

Radial lead type

■ Dimensions of carrier tape

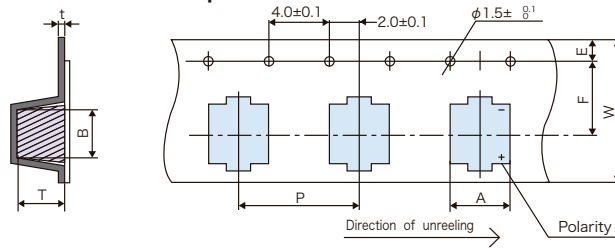

(unit : mm)

Size code	Dimensions	A±0.2	B±0.2	W±0.3	F±0.1	E±0.1	P±0.1	t±0.1	T±0.2
A5		4.7	4.7	12.0	5.5	1.75	8.0	0.4	5.8
B45		5.6	5.6	16.0	7.5	1.75	8.0	0.4	4.8
B6		5.6	5.6	16.0	7.5	1.75	8.0	0.4	6.2
C5		6.9	6.9	16.0	7.5	1.75	12.0	0.4	5.3
C55		6.9	6.9	16.0	7.5	1.75	12.0	0.4	6.2
C6		6.9	6.9	16.0	7.5	1.75	12.0	0.4	6.2
C65		6.9	6.9	16.0	7.5	1.75	12.0	0.4	6.7
C8		7.0	7.0	16.0	7.5	1.75	12.0	0.5	8.2
C10		7.0	7.0	24.0	11.5	1.75	16.0	0.5	10.5
C10L		7.0	7.0	16.0	7.5	1.75	12.0	0.5	11.0
E7		8.6	8.6	24.0	11.5	1.75	12.0	0.4	7.2
E10		8.6	8.6	24.0	11.5	1.75	16.0	0.5	11.0
E12		8.6	8.6	24.0	11.5	1.75	16.0	0.5	12.3
F8		10.7	10.7	24.0	11.5	1.75	16.0	0.4	8.2
F10		10.7	10.7	24.0	11.5	1.75	16.0	0.4	11.0
F12		10.7	10.7	24.0	11.5	1.75	16.0	0.4	13.0

■ Reel dimensions

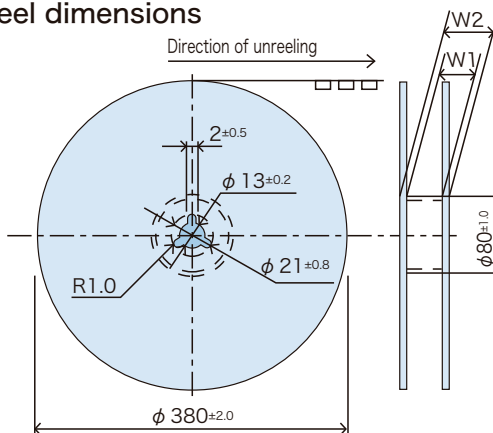

(Unit: mm)

Size code	W1±0.5	W2±1.0
A5	13.0	17.5
B45, B6, C5, C55, C6, C65, C8, C10L	17.0	21.5
C10, E7, E10, E12, F8, F10, F12	25.0	29.5

■ Minimum packing quantity and weight

Size code	Quantity(pcs./Reel, φ 380)	Typical weight(g)
A5	2000	700
B45	2500	900
B6	1500	800
C5	1300	800
C55	1000	800
C6	1000	800
C65	1000	800
C8	900	800
C10	500	700
C10L	700	900
E7	1000	1100
E10	500	900
E12	400	800
F8	500	1000
F10	500	1000
F12	400	1000

Radial lead type

SP-Cap

Guidelines and Precautions
Mounting specifications
Packing specifications

Selection guide

Surface mount type

Catalog EOL models

POSCAP

Guidelines and Precautions
Mounting specifications
Packing specifications

Selection guide

Surface mount type

Catalog Deletion models
Catalog EOL models

OS-CON

Guidelines and Precautions
Mounting specifications
Packing specifications

Line-up
Series system diagram
Size list

Products list

SVT
SVPT
SVF
SVPK
SXV
SVPG
SVPF
SVPA
SVP
SVPB
SVPD
SVP
SVP
SVPE
SVQP
SVP
SEK
SEF
SEPG
SXE
SEPF
SEPC
SEQP
SEP

Catalog EOL models

Hybrid

Guidelines and Precautions
Mounting specifications
Packing specifications

Selection guide

Surface mount type

Radial lead type

Correspondence list

※ The following table is a standard specification. Please contact us separately concerning specifications except for that mentioned below.
Because of a limit on the length of a model name, the part of process name changes to +S from +TSS, +D from +TS, +3 from +C3. Please contact us for details.

Series	Size code	Bag-packed products (lead terminal cutting)		Taping products
		Not processed	Straight cut	
SEP, SEQP, SEPC, SEPF, SXE, SEPG, SEK, SEF	B9, C55, C6, C9, C10, E7, E9, E12	No code	+C3(+3)	+TSS (+S)
	E13	No code	+C3(+3)	+TS (+D)
	F8, F13	No code	+C3(+3)	+T

Lead terminal cutting specifications

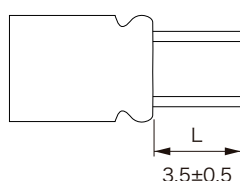
Process names	Size code	Lead terminal cutting code	Lead terminal dimensions (mm)
Straight cut	B9, C55, C6, C9, C10, E7, E9, E12, E13, F8, F13	+C3 (+3)	

Taping specifications for automatic insertion

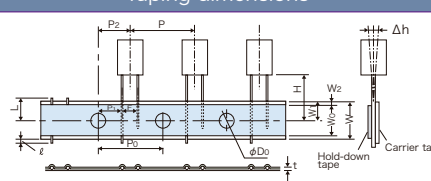
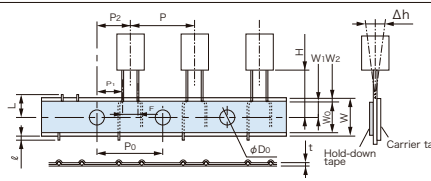
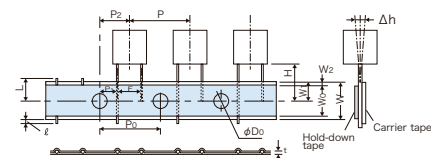
Size code	F	Case code	Taping code	Taping dimensions
B9	φ5	F=2.0 mm	+TSS (+S)	
C55, C6, C9, C10	φ6.3	F=2.5 mm		
E7, E9, E12	φ8	F=3.5 mm		
E13	φ8	F=3.5 mm	+TS (+D)	
F8, F13	φ10	F=5.0 mm	+T	

(unit : mm)

Code	F	P	P ₀	P ₁	P ₂	Δh	W	W ₀	W ₁	W ₂	H	φD ₀	t	l	L	
Tolerance	± 0.8	±1.0	±0.2	±0.5	±1.0	±1.0	±0.5	min.	±0.5	max	±0.75	±0.2	±0.3	max	max	
+TSS (+S)	φ 5	2.0	12.7	12.7	5.35	6.35	0	18.0	9.5	9.0	2.5	17.5	4.0	0.6	0	11.0
	φ 6.3	2.5	12.7	12.7	5.10	6.35	0	18.0	9.5	9.0	2.5	17.5	4.0	0.6	0	11.0
	φ 8	3.5	12.7	12.7	4.60	6.35	0	18.0	9.5	9.0	2.5	17.5	4.0	0.6	0	11.0
+TS(+D)	φ 8	3.5	12.7	12.7	3.85	6.35	0	18.0	9.5	9.0	2.5	18.5	4.0	0.6	0	11.0
+T	φ 10	5.0	12.7	12.7	4.60	6.35	0	18.0	9.5	9.0	2.5	17.5	4.0	0.6	0	11.0

Minimum packing quantity and weight

Size code	Case size	Bag-packed products		Taping products	
		Quantity (pcs./Bag)	Typical weight (g)	Quantity (pcs./Box)	Typical weight (g)
B9	φ 5	500	180	2000	1000
C55	φ 6.3	500	150	1500	650
C6	φ 6.3	500	160	1500	700
C9	φ 6.3	500	240	1500	1000
C10	φ 6.3	500	260	1500	1100
E7	φ 8	200	110	1000	820

Size code	Case size	Bag-packed products		Taping products	
		Quantity (pcs./Bag)	Typical weight (g)	Quantity (pcs./Box)	Typical weight (g)
E9	φ 8	200	130	1000	900
E12	φ 8	200	200	1000	980
E13	φ 8	200	160	1000	1060
F8	φ 10	200	180	500	890
F13	φ 10	200	280	500	940

Line-up

SP-Cap

SMD type

Guidelines and Precautions
Mounting specifications
Packing specifications

Selection guide

Surface mount type

Catalog EOL models

POSCAP

Guidelines and Precautions
Mounting specifications
Packing specifications

Selection guide

Surface mount type

Catalog Deletion models

Catalog EOL models

OS-CON

Guidelines and Precautions
Mounting specifications
Packing specifications

Line-up

Series system diagram

Size list

Products list

SVT

SVPT

SVF

SVPK

SXV

SVPG

SVPF

SVPA

SVPC

SVPE

SVQV

SVP

SEK

SEF

SEPG

SXE

SEPF

SEPC

SEQP

SEP

Catalog EOL models

Hybrid

Guidelines and Precautions
Mounting specifications
Packing specifications

Selection guide

Surface mount type

Radial lead type

Series	Page	Features	Small size/Low profile	Large capacitance	Low ESR	High voltage	Long life/High reliability	Category temperature range (°C)	Rated voltage (V)	ESR (mΩ)	Capacitance (μF)	Marking color	Size code	Size (mm)	
														φD	L
SVT	87 to 88	Low ESR Large capacitance 125 °C 2000 h	●	●	●	●	●	-55 to 125	2.5 to 16	15 to 24	100 to 680	Purple	C65	6.3	6.4
								-55 to 125	2.5 to 50	20 to 35	18 to 680	Purple	E7	8.0	6.9
								-55 to 125	2.5 to 50	10 to 25	39 to 1500	Purple	E12	8.0	11.9
								-55 to 125	2.5 to 50	12 to 20	68 to 2700	Purple	F12	10.0	12.6
SVPT	89	Low ESR Large capacitance 105°C 20000h	●	●	●	●	●	-55 to 105	2.5 to 16	15 to 24	100 to 680	Purple	C65	6.3	6.4
								-55 to 105	2.5 to 50	20 to 35	18 to 680	Purple	E7	8.0	6.9
								-55 to 105	2.5 to 50	10 to 25	39 to 1500	Purple	E12	8.0	11.9
								-55 to 105	2.5 to 50	12 to 20	68 to 2700	Purple	F12	10.0	12.6
SVF	90	High voltage Large capacitance 125 °C 1000 h	●	●	●	●	●	-55 to 125	16 to 25	27 to 40	27 to 82	Purple	B6	5.0	5.9
								-55 to 125	16 to 50	22 to 40	10 to 180	Purple	C6	6.3	5.9
								-55 to 125	16 to 50	22 to 35	18 to 270	Purple	E7	8.0	6.9
								-55 to 125	16 to 50	14 to 25	39 to 560	Purple	E12	8.0	11.9
								-55 to 125	16	16	1000	Purple	F10	10.0	10.0
								-55 to 125	16 to 50	12 to 20	68 to 1000	Purple	F12	10.0	12.6
SVPK	91 to 92	High voltage Large capacitance 125 °C 1000 h	●	●	●	●	●	-55 to 125	16 to 50	27 to 80	10 to 100	Purple	B6	5.0	5.9
								-55 to 125	16 to 50	22 to 35	22 to 220	Purple	C6	6.3	5.9
								-55 to 125	16 to 50	22 to 35	33 to 330	Purple	E7	8.0	6.9
								-55 to 125	16 to 50	14 to 25	68 to 680	Purple	E12	8.0	11.9
SXV	93	Super high voltage 125 °C 1000 h	●	●	●	●	●	-55 to 125	63 to 100	60	6.8 to 18	Purple	E7	8.0	6.9
								-55 to 125	63 to 100	50 to 60	15 to 39	Purple	F8	10.0	7.9
								-55 to 125	63 to 100	25 to 40	15 to 56	Purple	E12	8.0	11.9
								-55 to 125	63 to 100	25 to 30	18 to 100	Purple	F12	10.0	12.6
SVPG	94	Low ESR High ripple current 105 °C 5000 h	●	●	●	●	●	-55 to 105	16 to 25	25 to 30	15 to 47	Purple	B45	5.0	4.4
								-55 to 105	16	15	100	Purple	B6	5.0	5.9
								-55 to 105	16	14	220	Purple	C6	6.3	5.9
								-55 to 105	16	10	270	Purple	C8	6.3	7.9
								-55 to 105	16	8	270	Purple	C10	6.3	9.9
								-55 to 105	16	6.5	330	Purple	C10L	6.3	10.4
								-55 to 105	16	16	330	Purple	E7	8.0	6.9
								-55 to 105	16	10	560	Purple	E10	8.0	10.0
								-55 to 105	16	8	680	Purple	E12	8.0	11.9
								-55 to 105	16	9	820	Purple	F10	10.0	10.0
SVPF	95	High voltage Large capacitance 105 °C 5000 h	●	●	●	●	●	-55 to 105	16 to 25	27 to 40	27 to 82	Purple	B6	5.0	5.9
								-55 to 105	16 to 50	22 to 40	10 to 180	Purple	C6	6.3	5.9
								-55 to 105	16 to 50	22 to 35	18 to 270	Purple	E7	8.0	6.9
								-55 to 105	16	18	560	Purple	E10	8.0	10.0
								-55 to 105	16 to 50	14 to 25	39 to 560	Purple	E12	8.0	11.9
								-55 to 105	16	16	1000	Purple	F10	10.0	10.0
SVPA	96	Low ESR High ripple current	●	●	●	●	●	-55 to 105	2.5 to 20	30 to 40	10 to 82	Purple	B6	5.0	5.9
								-55 to 105	2.5 to 20	20 to 35	22 to 180	Purple	C6	6.3	5.9
								-55 to 105	2.5 to 20	20 to 33	47 to 330	Purple	E7	8.0	6.9
								-55 to 105	2.5 to 16	19 to 29	180 to 820	Purple	F8	10.0	7.9
								-55 to 105	2.5 to 16	19 to 35	39 to 180	Purple	B6	5.0	5.9
								-55 to 105	2.5 to 16	15 to 30	68 to 560	Purple	C6	6.3	5.9
SVPC	97 to 98	Low ESR Large capacitance	●	●	●	●	●	-55 to 105	2.5 to 16	19 to 27	120 to 680	Purple	E7	8.0	6.9
								-55 to 105	2.5 to 16	9 to 16	270 to 1500	Purple	E12	8.0	11.9
								-55 to 105	2.5	12	2700	Purple	F12	10.0	12.6
								-55 to 105	2.5 to 20	40 to 45	15 to 120	Purple	C5	6.3	4.9
SVPB	99	Low profile	●	●	●	●	●	-55 to 105	20	35	22	Purple	C55	6.3	5.4
								-55 to 105	10 to 25	45 to 65	10 to 56	Purple	C6	6.3	5.9
SVPD	100	Guaranteed at 125 °C High voltage 85 °C 85 % RH	●	●	●	●	●	-55 to 125	16 to 35	40 to 70	8.2 to 82	Purple	E7	8.0	6.9
								-55 to 125	25 to 35	45 to 60	18 to 39	Purple	F8	10.0	7.9
								-55 to 125	25 to 35	30 to 50	22 to 47	Purple	E12	8.0	11.9
								-55 to 125	25 to 35	28 to 30	47 to 82	Purple	F12	10.0	12.6
SVPS	101 to 102	Long life	●	●	●	●	●	-55 to 105	4.0 to 10	200 to 220	10 to 33	Purple	A5	4.0	5.4
								-55 to 105	4.0 to 16	30 to 90	22 to 68	Purple	B6	5.0	5.9
								-55 to 105	4.0 to 20	22 to 60	22 to 150	Purple	C6	6.3	5.9
								-55 to 105	4.0 to 25	22 to 60	10 to 270	Purple	E7	8.0	6.9
SVPE	103	Low ESR Large capacitance	●	●	●	●	●	-55 to 105	2.5 to 6.3	10 to 15	150 to 390	Purple	B6	5.0	5.9
								-55 to 105	2.5 to 10	10 to 20	220 to 390	Purple	C6	6.3	5.9
								-55 to 105	2.0 to 16	8 to 11	180 to 1200	Purple	C10	6.3	9.9
								-55 to 105	16	10	470	Purple	F12	10.0	12.6
SVQP	104	Guaranteed at 125 °C	●	●	●	●	●	-55 to 125	4.0 to 20	40 to 60	22 to 150	Purple	C6	6.3	5.9
								-55 to 125	6.3 to 20	35 to 45	47 to 220	Purple	E7	8.0	6.9

SMD type

Series	Page	Features	Small size/Low profile	Large capacitance	Low ESR	High voltage	Long life/High reliability	Category temperature range (°C)	Rated voltage (V)	ESR (mΩ)	Capacitance (μF)	Marking color	Size code	Size (mm)	
														φD	L
SVP	105 to 106	Standard						-55 to 105	4.0 to 16	200 to 260	3.3 to 33	Purple	A5	4.0	5.4
								-55 to 105	4.0 to 20	60 to 120	10 to 68	Purple	B6	5.0	5.9
								-55 to 105	2.5 to 20	23 to 60	22 to 220	Purple	C6	6.3	5.9
								-55 to 105	4.0 to 20	35 to 45	33 to 330	Purple	E7	8.0	6.9
								-55 to 105	4.0 to 20	25 to 40	56 to 680	Purple	F8	10.0	7.9
								-55 to 105	2.5 to 20	13 to 24	100 to 680	Purple	E12	8.0	11.9
								-55 to 105	2.5 to 20	12 to 20	150 to 1500	Purple	F12	10.0	12.6

Radial lead type

Series	Page	Features	Small size/Low profile	Large capacitance	Low ESR	High voltage	Long life/High reliability	Category temperature range (°C)	Rated voltage (V)	ESR (mΩ)	Capacitance (μF)	Marking color	Size code	Size (mm)	
														φD	L
SEK	107	High voltage Large capacitance 125 °C 1000 h	●	●	●	●	●	-55 to 125	25 to 50	25 to 35	22 to 82	Purple	C6	6.3	5.9
								-55 to 125	25 to 50	24 to 35	33 to 120	Purple	E7	8.0	6.9
								-55 to 125	25 to 50	16 to 25	68 to 270	Purple	E12	8.0	11.9
								-55 to 125	25 to 50	14 to 20	120 to 470	Purple	F13	10.0	12.9
SEF	108	High voltage Large capacitance 125 °C 1000 h	●	●	●	●	●	-55 to 125	16 to 35	22 to 35	22 to 180	Purple	C6	6.3	5.9
								-55 to 125	16 to 35	22 to 30	39 to 270	Purple	E7	8.0	6.9
								-55 to 125	16 to 35	14 to 20	82 to 560	Purple	E12	8.0	11.9
								-55 to 125	16 to 35	12 to 18	120 to 1000	Purple	F13	10.0	12.9
SEPG	109	Low ESR High ripple current 105 °C 5000 h			●	●	●	-55 to 105	16	12	150	Purple	B9	5.0	8.9
								-55 to 105	16	10	270	Purple	C9	6.3	8.9
								-55 to 105	16	8	270	Purple	C10	6.3	9.9
								-55 to 105	16	8	470	Purple	E9	8.0	8.9
								-55 to 105	16	8	560	Purple	E13	8.0	12.9
SXE	110	Super high voltage 125 °C 1000 h				●	●	-55 to 125	63 to 100	60	6.8 to 18	Purple	E7	8.0	6.9
								-55 to 125	63 to 100	50 to 60	15 to 39	Purple	F8	10.0	7.9
								-55 to 125	63 to 100	25 to 40	15 to 56	Purple	E12	8.0	11.9
								-55 to 125	63 to 100	25 to 30	18 to 100	Purple	F13	10.0	12.9
SEPF	111 to 112	Small size / Low profile High voltage Large capacitance 105 °C 5000 h	●	●	●	●	●	-55 to 105	16 to 32	30 to 35	22 to 150	Purple	C55	6.3	5.4
								-55 to 105	16 to 35	22 to 35	22 to 180	Purple	C6	6.3	5.9
								-55 to 105	16 to 35	22 to 30	39 to 270	Purple	E7	8.0	6.9
								-55 to 105	16 to 35	14 to 20	82 to 560	Purple	E12	8.0	11.9
								-55 to 105	16 to 35	12 to 18	120 to 1000	Purple	F13	10.0	12.9
SEPC	113 to 114	Super low ESR Large capacitance Small size / Low profile 105 °C 5000 h	●	●	●	●	●	-55 to 105	2.5	7	100 to 560	Purple	B9	5.0	8.9
								-55 to 105	6.3	18	220	Purple	C55	6.3	5.4
								-55 to 105	2.5 to 16	10 to 24	100 to 560	Purple	C6	6.3	5.9
								-55 to 105	2.5 to 16	7 to 10	100 to 820	Purple	C9	6.3	8.9
								-55 to 105	2.5 to 16	8 to 22	150 to 1000	Purple	E7	8.0	6.9
								-55 to 105	2.5 to 16	5 to 10	180 to 1000	Purple	E9	8.0	8.9
								-55 to 105	16	11 to 16	180 to 270	Purple	E12	8.0	11.9
								-55 to 105	2.5 to 6.3	7 to 8	470 to 820	Purple	E13	8.0	12.9
								-55 to 105	2.5 to 16	7 to 10	470 to 2700	Purple	F13	10.0	12.9
								-55 to 105	2.5 to 16	7 to 10	470 to 2700	Purple	F13	10.0	12.9
SEQP	115 to 116	Guaranteed at 125 °C R. voltage 32 V max. 105 °C 5000 h				●	●	-55 to 125	4.0 to 20	40 to 60	22 to 150	Purple	C6	6.3	5.9
								-55 to 125	4.0 to 32	35 to 100	6.8 to 330	Purple	E7	8.0	6.9
								-55 to 125	4.0 to 32	25 to 80	15 to 680	Purple	F8	10.0	7.9
								-55 to 125	4.0 to 32	13 to 50	18 to 560	Purple	E12	8.0	11.9
SEP	117 to 118	Standard						-55 to 105	4.0 to 20	40 to 60	22 to 150	Purple	C6	6.3	5.9
								-55 to 105	4.0 to 20	35 to 45	33 to 330	Purple	E7	8.0	6.9
								-55 to 105	4.0 to 20	25 to 40	56 to 680	Purple	F8	10.0	7.9
								-55 to 105	2.5 to 20	13 to 24	100 to 680	Purple	E12	8.0	11.9
								-55 to 105	2.5 to 20	12 to 20	150 to 1500	Purple	F13	10.0	12.9

SP-Cap

Guidelines and Precautions
Mounting specifications
Packing specifications

Selection guide

Surface mount type

Catalog EOL models

POSCAP

Guidelines and Precautions
Mounting specifications
Packing specifications

Selection guide

Surface mount type

Catalog Deletion models

Catalog EOL models

OS-CON

Guidelines and Precautions
Mounting specifications
Packing specifications

Line-up
Series system diagram
Size list

Products list

- SVT
- SVPT
- SVF
- SVPK
- SXV
- SVPG
- SVPF
- SVPA
- SVPC
- SVPB
- SVPD
- SVPS
- SVPE
- SVQP
- SVP
- SEK
- SEF
- SEPG
- SXE
- SEPF
- SEPC
- SEQP
- SEP

Catalog EOL models

Hybrid

Guidelines and Precautions
Mounting specifications
Packing specifications

Selection guide

Surface mount type

Radial lead type

Series system diagram / Size chart

SP-Cap

Guidelines and Precautions
Mounting specifications
Packing specifications

Selection guide

Surface mount type

POSCAP

Guidelines and Precautions
Mounting specifications
Packing specifications

Selection guide

Surface mount type

Catalog Deletion models

Catalog EOL models

OS-CON

Guidelines and Precautions
Mounting specifications
Packing specifications

Line-up

Series system diagram

Size chart

Selection guide

Products list

SVT

SVPT

SVF

SVXV

SVPG

SVPF

SVPA

SVPC

SVPB

SVPD

SVPS

SVPE

SVQP

SVP

SEK

SEF

SEPG

SXE

SEPF

SEPC

SEQP

SEP

Catalog EOL models

Hybrid

Guidelines and Precautions
Mounting specifications
Packing specifications

Selection guide

Surface mount type

Radial lead type

SMD type

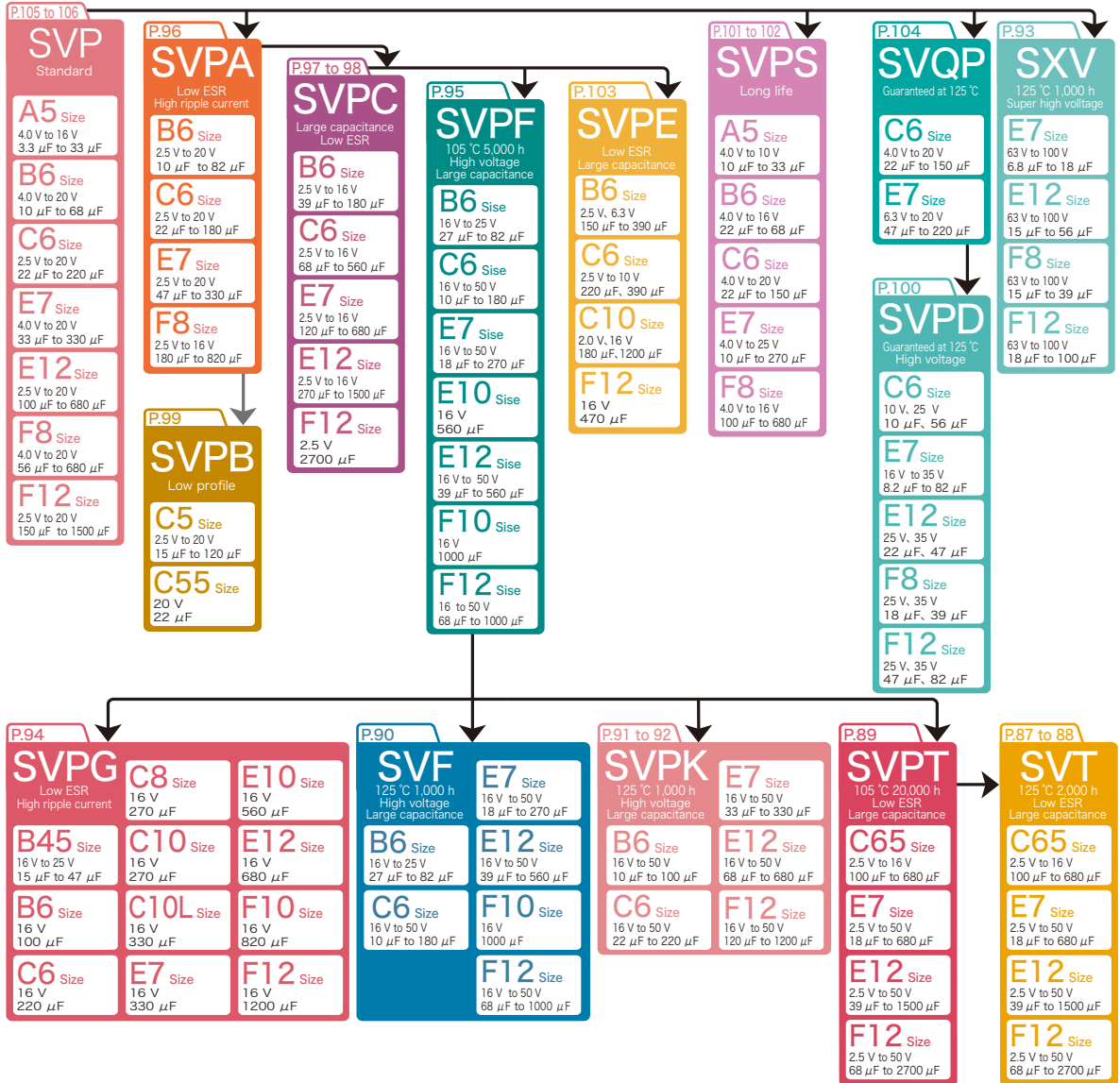

Radial lead type

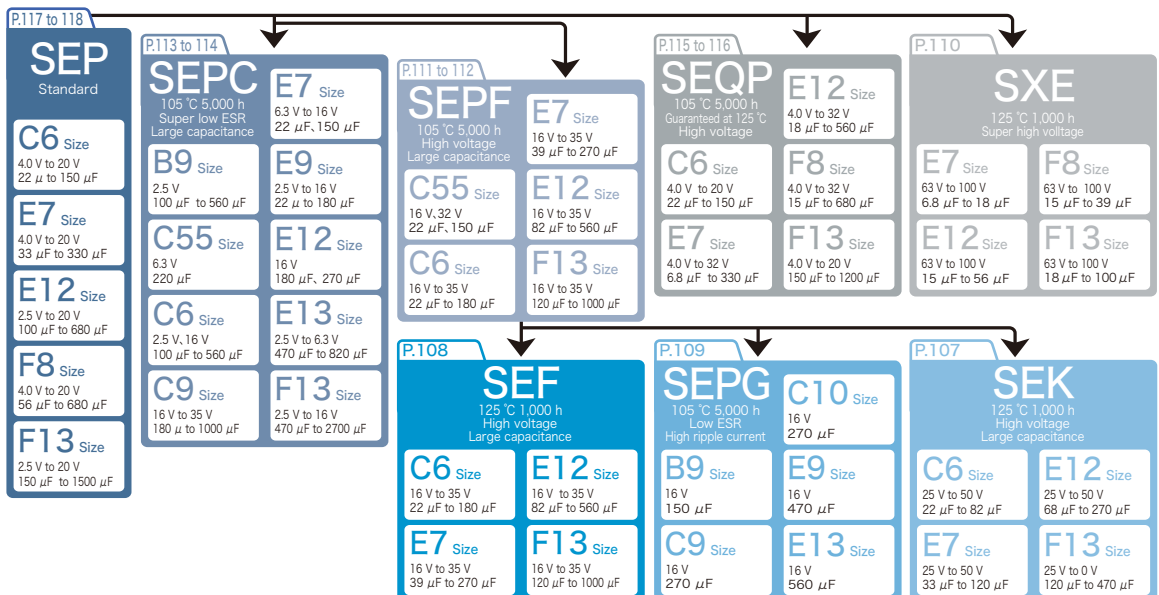

- SVT
- SVPT
- SVF
- SVPK
- SXV
- SVPG
- SVPF
- SVPA
- SVPC
- SVPB
- SVPD
- SVPS
- SVPE
- SVQP
- SVP
- SEK
- SEF
- SEPG
- SXE
- SEPF
- SEPC
- SEQP
- SEP

SMD type

LxWxH(Unit:mm)																
A5 size	B45 size	B6 size	C5 size	C55 size	C6 size	C65 size	C8 size	C10 size	C10L size	E7 size	E10 size	E12 size	F8 size	F10 size	F12 size	
P.101 to 102 SVPS P.105 to 106 SVP	P.94 SVPG	P.90 SVF P.91 to 92 SVPK P.94 SVPG P.95 SVPF P.96 SVPA P.97 to 98 SVPC P.101 to 102 SVPS P.103 SVPE P.105 to 106 SVP	P.99 SVPB	P.99 SVPB	P.90 SVF P.91 to 92 SVPK P.94 SVPG P.95 SVPF P.96 SVPA P.97 to 98 SVPC P.100 SVPD P.101 to 102 SVPS P.103 SVPE P.104 SVQP P.105 to 106 SVP	P.87 to 88 SVT P.89 SVPT	P.94 SVPG	P.94 SVPG	P.94 SVPG	P.87 to 88 SVT P.89 SVPT P.90 SVF P.91 to 92 SVPK P.93 SXV P.94 SVPG P.95 SVPF P.96 SVPA P.97 to 98 SVPC P.100 SVPD P.101 to 102 SVPS P.104 SVQP P.105 to 106 SVP	P.94 SVPG	P.87 to 88 SVT P.89 SVPT P.90 SVF P.91 to 92 SVPK P.93 SXV P.94 SVPG P.95 SVPF P.96 SVPA P.97 to 98 SVPC P.100 SVPD P.101 to 102 SVPS P.104 SVQP P.105 to 106 SVP	P.93 SXV P.96 SVPA P.100 SVPD P.101 to 102 SVPS	P.90 SVF P.94 SVPG P.95 SVPF	P.87 to 88 SVT P.89 SVPT P.90 SVF P.91 to 92 SVPK P.93 SXV P.94 SVPG P.95 SVPF P.96 SVPA P.97 to 98 SVPC P.100 SVPD P.101 to 102 SVPS	P.87 to 88 SVT P.89 SVPT P.90 SVF P.91 to 92 SVPK P.93 SXV P.94 SVPG P.95 SVPF P.96 SVPA P.97 to 98 SVPC P.100 SVPD P.101 to 102 SVPS

※ Profile of case size are all indicated in maximum values.

Radial lead type

LxWxH(Unit:mm)															
B9 size	C55 size	C6 size	C6 size	C9 size	C10 size	E7 size	E7 size	E9 size	E12 size	E12 size	E13 size	F8 size	F8 size	F13 size	F13 size
P.109 SEPG	P.111 to 112 SEPF	P.108 SEF	P.115 to 116 SEQP	P.109 SEPG	P.109 SEPG	P.108 SEF	P.115 to 116 SEQP	P.109 SEPG	P.107 SEK	P.113 to 114 SEPC	P.113 to 114 SEPC	P.110 SXE	P.115 to 116 SEQP	P.107 SEK	P.113 to 114 SEPC
P.113 to 114 SEPC	P.113 to 114 SEPC	P.111 to 112 SEPF P.112 to 114 SEPC P.107 SEK	P.117 to 118 SEP	P.113 to 114 SEPC		P.110 SXE	P.117 to 118 SEP	P.113 to 114 SEPC	P.108 SEF	P.115 to 116 SEQP	P.109 SEPG		P.117 to 118 SEP	P.108 SEF	P.115 to 116 SEQP
						P.111 to 112 SEPF P.112 to 114 SEPC P.107 SEK			P.110 SXE	P.117 to 118 SEP				P.110 SXE	P.117 to 118 SEP

※ Profile of case size are all indicated in maximum values.



Low ESR(10 mΩ max.)

Large capacitance(2700 μF max.)

Guaranteed at 125 °C 2000 h

RoHS compliance, Halogen free

SP-Cap

Guidelines and Precautions
Mounting specifications
Packing specifications

Selection guide

Surface mount type

Catalog EOL models

POSCAP

Guidelines and Precautions
Mounting specifications
Packing specifications

Selection guide

Surface mount type

Catalog Deletion models

Catalog EOL models

OS-CON

Guidelines and Precautions
Mounting specifications
Packing specifications

Line-up

Series system diagram

Size chart

Products list

Selection guide

SVT

SVPT

SVF

SVPK

SXV

SVPG

SVPF

SVPA

SVPC

SVPB

SVPD

SVPS

SVPE

SVQP

SVP

SEK

SEF

SEPG

SXE

SEPF

SEPC

SEQP

SEP

Surface mount type

Radial lead type

Catalog EOL models

Hybrid

Guidelines and Precautions
Mounting specifications
Packing specifications

Selection guide

Surface mount type

Radial lead type

Specifications

Items	Specifications			
	Size code	C65	E7	E12
Category temperature range	-55 °C to +125 °C			
Rated voltage range	2.5 V to 16 V		2.5 V to 50 V	
Rated capacitance range	100 μF to 680 μF	18 μF to 680 μF	39 μF to 1500 μF	68 μF to 2700 μF
Capacitance tolerance	±20 % (120 Hz/+20 °C)			
Leakage current	Please see the attached characteristics list			
Dissipation factor(tanδ)	Please see the attached characteristics list			
Endurance	+125 °C 2000 h, rated voltage applied			
	Capacitance change	Within ±20 % of the initial value		
	tanδ	≤ 200 % of the initial limit		
	DC leakage current	Within the initial limit		
Damp heat(Steady state)	+60 °C, 90 % to 95 % RH, 1000 h, No-applied voltage			
	Capacitance change	Within ±20 % of the initial value		
	tanδ	≤ 150 % of the initial limit		
	DC leakage current	Within the initial limit (after voltage processing)		

Marking and Dimensions

Lot No.

Series code※

R. capacitance(μF)

R. voltage(V)

0.2 max

(-)

(+)

(unit : mm)

Size code	φD ±0.5	L ^{+0.1} / _{-0.4}	W ±0.2	H ±0.2	C ±0.2	R	P ※1
C65	6.3	6.4	6.6	6.6	7.3	0.6 to 0.8	2.1
E7	8.0	6.9	8.3	8.3	9.0	0.6 to 0.8	3.2
E12	8.0	11.9	8.3	8.3	9.0	0.8 to 1.1	3.2
F12	10.0	12.6	10.3	10.3	11.0	0.8 to 1.1	4.6

※ Depends on the case size.

※1 Reference

Characteristics list

Series	Rated voltage (V)	Rated capacitance (μF)	Case size (mm)		Size code	Specifications					Standard(Reel size: φ 380)	
			φD	L		Ripple current ※1 (mA rms)	Allowable ripple current※1 (mA rms)	ESR ※2 (mΩ max.)	tan δ ※3	LC ※4 (μA)	Part number	Min. Packaging Qty (pcs)
SVT	2.5	560	6.3	6.4	C65	1100	3500	16	0.12	300	2R5SVT560M	1000
			6.3	6.4		1000	3500	16	0.12	850	2R5SVT680MX	1000
		680	8.0	6.9	E7	1060	3370	20	0.12	500	2R5SVT680M	1000
			8.0	11.9	E12	1620	5150	10	0.12	750	2R5SVT1500M	400
		2700	10.0	12.6	F12	1600	5070	12	0.12	1350	2R5SVT2700M	400
	4.0	560	8.0	6.9	E7	1010	3220	22	0.12	500	4SVT560M	1000
			8.0	11.9	E12	1480	4700	12	0.12	1200	4SVT1500M	400
	6.3	330	6.3	6.4	C65	1070	3390	15	0.12	415	6SVT330M	1000
			8.0	6.9	E7	1010	3220	22	0.12	491	6SVT390M	1000
			8.0	11.9	E12	1480	4700	12	0.12	1033	6SVT820M	400
	16	100	6.3	6.4	C65	780	2490	24	0.12	300	16SVT100M	1000
			8.0	6.9	E7	1040	3300	22	0.12	864	16SVT270M	1000
		560	8.0	11.9	E12	1560	4950	14	0.12	1792	16SVT560M	400
			10.0	12.6	F12	1700	5400	12	0.12	3200	16SVT1000M	400
	20	180	8.0	6.9	E7	1010	3200	25	0.12	720	20SVT180M	1000
			8.0	11.9	E12	1560	4950	14	0.12	1560	20SVT390M	400
			10.0	12.6	F12	1700	5400	12	0.12	2240	20SVT560M	400
	25	100	8.0	6.9	E7	1010	3200	24	0.12	500	25SVT100M	1000
			8.0	11.9	E12	1470	4650	16	0.12	900	25SVT180M	400
			10.0	12.6	F12	1580	5000	14	0.12	1650	25SVT330M	400
	35	39	8.0	6.9	E7	880	2800	30	0.12	273	35SVT39M	1000
			8.0	11.9	E12	1260	4000	20	0.12	574	35SVT82M	400
			10.0	12.6	F12	1390	4400	18	0.12	840	35SVT120M	400
	50	18	8.0	6.9	E7	850	2700	35	0.12	180	50SVT18M	1000
8.0			11.9	E12	1200	3800	25	0.12	390	50SVT39M	400	
10.0			12.6	F12	1350	4300	20	0.12	680	50SVT68M	400	

※1: Ripple current(100 kHz / +105 °C < Tx ≤ +125 °C) / Allowable ripple current (100 kHz / Tx ≤ +105 °C)

Tx: Temperature measured at the top surface of aluminum case including self-heating by ripple current

※2: ESR(100 kHz to 300 kHz/+20 °C)

※3: tan δ (120 Hz/+20 °C)

※4: After 2 minutes

◆Please refer to each page in this catalog for "Reflow conditions" and "Taping specifications".

Frequency correction factor for ripple current

Frequency	120 Hz ≤ f < 1 kHz	1 kHz ≤ f < 10 kHz	10 kHz ≤ f < 100 kHz	100 kHz ≤ f ≤ 500 kHz
Coefficient	0.05	0.3	0.7	1

SP-Cap

Guidelines and Precautions
Mounting specifications
Packing specifications

Selection guide

Surface mount type

Catalog EOL models

POSCAP

Guidelines and Precautions
Mounting specifications
Packing specifications

Selection guide

Surface mount type

Catalog Deletion models

Catalog EOL models

OS-CON

Guidelines and Precautions
Mounting specifications
Packing specifications

Selection guide
Line-up
Series, system diagram
Size chart

Products list

SVT
SVPT
SVF
SVPK
SXV
SVPG
SVPF
SVPA
SVPC
SVPB
SVPD
SVPS
SVPE
SVQP
SVP

SEK
SEF
SEPG
SXE
SEPF
SEPC
SEQP
SEP

Catalog EOL models

Hybrid

Guidelines and Precautions
Mounting specifications
Packing specifications

Selection guide

Surface mount type

Radial lead type



Low ESR(10 mΩ max.)

Large capacitance(2700 μF max.)

Guaranteed at 105 °C 20000 h

RoHS compliance, Halogen free

SP-Cap

Guidelines and Precautions
Mounting specifications
Packing specifications

Selection guide

Surface mount type

Catalog EOL models

POSCAP

Guidelines and Precautions
Mounting specifications
Packing specifications

Selection guide

Surface mount type

Catalog Deletion models

Catalog EOL models

OS-CON

Guidelines and Precautions
Mounting specifications
Packing specifications

Line-up

Series system diagram
Size chart

Products list

SVT

SVPT

SVF

SVPK

SXV

SVPG

SVPF

SVPA

SVPC

SVPB

SVPD

SVPS

SVPE

SVQP

SVP

SEK

SEF

SEPG

SXE

SEPF

SEPC

SEQP

SEP

Catalog EOL models

Hybrid

Guidelines and Precautions
Mounting specifications
Packing specifications

Selection guide

Surface mount type

Radial lead type

Specifications

Items	Specifications			
	C65	E7	E12	F12
Size code	C65	E7	E12	F12
Category temperature range	-55 °C to +105 °C			
Rated voltage range	2.5 V to 16 V		2.5 V to 50 V	
Rated capacitance range	100 μF to 680 μF	18 μF to 680 μF	39 μF to 1500 μF	68 μF to 2700 μF
Capacitance tolerance	±20 % (120 Hz/+20 °C)			
Leakage current	Please see the attached characteristics list			
Dissipation factor(tanδ)	Please see the attached characteristics list			
Endurance	+105 °C, 20000 h, rated voltage applied			
	Capacitance change	Within ±20 % of the initial value		
	tanδ	≤ 150 % of the initial limit		
	DC leakage current	Within the initial limit		
Damp heat(Steady state)	+60 °C, 90 % to 95 % RH, 1000 h, No-applied voltage			
	Capacitance change	Within ±20 % of the initial value		
	tanδ	≤ 150 % of the initial limit		
	DC leakage current	Within the initial limit (after voltage processing)		

Marking and Dimensions

※ Depends on the case size.

(unit : mm)

Size code	φD ±0.5	L ^{+0.1} / _{-0.4}	W ±0.2	H ±0.2	C ±0.2	R	P ※1
C65	6.3	6.4	6.6	6.6	7.3	0.6 to 0.8	2.1
E7	8.0	6.9	8.3	8.3	9.0	0.6 to 0.8	3.2
E12	8.0	11.9	8.3	8.3	9.0	0.8 to 1.1	3.2
F12	10.0	12.6	10.3	10.3	11.0	0.8 to 1.1	4.6

※1 Reference

Characteristics list

Series	Rated voltage (V)	Rated capacitance (μF)	Case size (mm)		Size code	Specifications				Standard(Reel size: φ 380)	
			φD	L		Ripple current ※1 (mA rms)	ESR ※2 (mΩ max.)	tan δ ※3	LC ※4 (μA)	Part number	Min. Packaging Qty (pcs)
SVPT	2.5	560	6.3	6.4	C65	3500	16	0.12	300	2R5SVPT560M	1000
						3500	16	0.12	850	2R5SVPT680MX	1000
		680	8.0	6.9	E7	3370	20	0.12	500	2R5SVPT680M	1000
						5150	10	0.12	750	2R5SVPT1500M	400
		2700	10.0	12.6	F12	5070	12	0.12	1350	2R5SVPT2700M	400
						3220	22	0.12	500	4SVPT560M	1000
	4.0	560	8.0	6.9	E7	4700	12	0.12	1200	4SVPT1500M	400
						3390	15	0.12	415	6SVPT330M	1000
						3220	22	0.12	491	6SVPT390M	1000
	6.3	390	8.0	6.9	E7	4700	12	0.12	1033	6SVPT820M	400
						2490	24	0.12	300	16SVPT100M	1000
						3300	22	0.12	864	16SVPT270M	1000
		820	8.0	11.9	E12	4700	12	0.12	1792	16SVPT560M	400
						5400	12	0.12	3200	16SVPT1000M	400
						3200	25	0.12	720	20SVPT180M	1000
	16	270	8.0	6.9	E7	4950	14	0.12	864	20SVPT390M	400
						4950	14	0.12	1560	20SVPT390M	400
						5400	12	0.12	2240	20SVPT560M	400
		560	8.0	6.9	E7	3200	24	0.12	500	25SVPT100M	1000
						4650	16	0.12	900	25SVPT180M	400
						5000	14	0.12	1650	25SVPT330M	400
	20	39	8.0	6.9	E7	2800	30	0.12	273	35SVPT39M	1000
						4000	20	0.12	574	35SVPT82M	400
						4400	18	0.12	840	35SVPT120M	400
82		8.0	11.9	E12	2700	35	0.12	180	50SVPT18M	1000	
					3800	25	0.12	390	50SVPT39M	400	
					4300	20	0.12	680	50SVPT68M	400	

※1:Ripple current (100 kHz/ +105 °C):The surface temperature of aluminum case top must not exceed 105 °C. A rise in temperature due to self-heating by ripple current should be factored in.

※2:ESR (100 kHz to 300 kHz/+20 °C) ※3:tan δ (120 Hz/+20 °C) ※4:After 2 minutes ◆Please refer to each page in this catalog for "Reflow conditions" and "Taping specifications"

Frequency correction factor for ripple current

Frequency	120 Hz ≤ f < 1 kHz	1 kHz ≤ f < 10 kHz	10 kHz ≤ f < 100 kHz	100 kHz ≤ f ≤ 500 kHz
Coefficient	0.05	0.3	0.7	1

Design and specifications are each subject to change without notice. Ask factory for the current technical specifications before purchase and/or use. Should a safety concern arise regarding this product, please be sure to contact us immediately.



High voltage (50 V max.)

Large capacitance (1000 μ F max.)

Guaranteed at 125 °C 1000 h

RoHS compliance, Halogen free

Specifications

Items	Specifications					
	B6	C6	E7	E12	F10	F12
Size code	B6	C6	E7	E12	F10	F12
Category temperature range	-55 °C to +125 °C					
Rated voltage range	16 V to 25 V		16 V to 50 V		16 V	16 V to 50 V
Rated capacitance range	27 μ F to 82 μ F	10 μ F to 180 μ F	18 μ F to 270 μ F	39 μ F to 560 μ F	1000 μ F	68 μ F to 1000 μ F
Capacitance tolerance	\pm 20 % (120 Hz/+20 °C)					
Leakage current	Please see the attached characteristics list					
Dissipation factor (tan δ)	Please see the attached characteristics list					
Endurance	+125 °C, 1000 h, rated voltage applied					
	Capacitance change	Within \pm 20 % of the initial value				
	tan δ	\leq 200 % of the initial limit				
	DC leakage current	Within the initial limit				
Damp heat (Steady state)	+60 °C, 90 % to 95 % RH, 1000 h, No-applied voltage					
	Capacitance change	Within \pm 20 % of the initial value				
	tan δ	\leq 150 % of the initial limit				
	DC leakage current	Within the initial limit (after voltage processing)				

Marking and Dimensions

Lot. No.
Series code**
R. capacitance (μ F)
R. voltage (V)

0.2 max

(-)

(+)

Size code	ϕ D \pm 0.5	L $\begin{smallmatrix} +0.1 \\ -0.4 \end{smallmatrix}$	W \pm 0.2	H \pm 0.2	C \pm 0.2	R	P \pm 2
B6	5.0	5.9	5.3	5.3	6.0	0.6 to 0.8	1.4
C6	6.3	5.9	6.6	6.6	7.3	0.6 to 0.8	2.1
E7	8.0	6.9	8.3	8.3	9.0	0.6 to 0.8	3.2
E12	8.0	11.9	8.3	8.3	9.0	0.8 to 1.1	3.2
F10	10.0	10.0**1	10.3	10.3	11.0	0.8 to 1.1	4.6
F12	10.0	12.6	10.3	10.3	11.0	0.8 to 1.1	4.6

(unit : mm)

**1: \pm 0.5 **2 Reference

Characteristics list

Series	Rated voltage (V)	Rated capacitance (μ F)	Case size (mm)		Size code	Specifications					Standard (Reel size: ϕ 380)	
			ϕ D	L		Ripple current \times 1 (mA rms)	Allowable ripple current \times 1 (mA rms)	ESR \times 2 (m Ω max.)	tan δ \times 3	LC \times 4 (μ A)	Part number	Min. Packaging Qty (pcs)
SVF	16	82	5.0	5.9	B6	940	3000	27	0.12	262	16SVF82M	1500
		180	6.3	5.9	C6	1040	3300	22	0.12	576	16SVF180M	1000
		270	8.0	6.9	E7	1040	3300	22	0.12	864	16SVF270M	1000
		560	8.0	11.9	E12	1560	4950	14	0.12	1792	16SVF560M	400
		1000	10.0	10.0	F10	1350	4300	16	0.12	3200	16SVF1000MX	500
			10.0	12.6	F12	1700	5400	12	0.12	3200	16SVF1000M	400
	20	56	5.0	5.9	B6	880	2800	30	0.12	224	20SVF56M	1500
		120	6.3	5.9	C6	1010	3200	25	0.12	480	20SVF120M	1000
		180	8.0	6.9	E7	1010	3200	25	0.12	720	20SVF180M	1000
		390	8.0	11.9	E12	1560	4950	14	0.12	1560	20SVF390M	400
		560	10.0	12.6	F12	1700	5400	12	0.12	2240	20SVF560M	400
			10.0	12.6	F12	1700	5400	12	0.12	2240	20SVF560M	400
	25	27	5.0	5.9	B6	770	2450	40	0.12	135	25SVF27M	1500
		47	6.3	5.9	C6	880	2800	30	0.12	235	25SVF47M	1000
		56	6.3	5.9		880	2800	30	0.12	280	25SVF56M	1000
		82	8.0	6.9		E7	940	3000	28	0.12	410	25SVF82M
		100	8.0	6.9	1010		3200	24	0.12	500	25SVF100M	1000
		180	8.0	11.9	E12		1470	4650	16	0.12	900	25SVF180M
	330	10.0	12.6	F12	1580	5000	14	0.12	1650	25SVF330M	400	
	35	22	6.3	5.9	C6	820	2600	35	0.12	154	35SVF22M	1000
		39	8.0	6.9	E7	880	2800	30	0.12	273	35SVF39M	1000
		82	8.0	11.9	E12	1260	4000	20	0.12	574	35SVF82M	400
		120	10.0	12.6	F12	1390	4400	18	0.12	840	35SVF120M	400
	50	10	6.3	5.9	C6	790	2500	40	0.12	100	50SVF10M	1000
18		8.0	6.9	E7	850	2700	35	0.12	180	50SVF18M	1000	
39		8.0	11.9	E12	1200	3800	25	0.12	390	50SVF39M	400	
68		10.0	12.6	F12	1350	4300	20	0.12	680	50SVF68M	400	

\times 1: Ripple current (100 kHz/ +105 °C < Tx \leq +125 °C) / Allowable ripple current (100 kHz/ Tx \leq +105 °C) \times 2: ESR (100 kHz to 300 kHz/+20 °C)
 \times 3: tan δ (120 Hz/+20 °C) \times 4: After 2 minutes \blacklozenge Please refer to each page in this catalog for "Reflow conditions" and "Taping specifications"

Frequency correction factor for ripple current

Frequency	120 Hz \leq f < 1 kHz	1 kHz \leq f < 10 kHz	10 kHz \leq f < 100 kHz	100 kHz \leq f \leq 500 kHz
Coefficient	0.05	0.3	0.7	1

SP-CAP

Guidelines and Precautions
Mounting specifications
Packing specifications

Selection guide

Surface mount type

Catalog EOL models

POSCAP

Guidelines and Precautions
Mounting specifications
Packing specifications

Selection guide

Surface mount type

Catalog Deletion models

Catalog EOL models

OS-CON

Guidelines and Precautions
Mounting specifications
Packing specifications

Selection guide
Line-up
Series system diagram
Size chart

Products list

- SVT
- SVPT
- SVF**
- SVPK
- SXV
- SVPG
- SVPF
- SVPA
- SVPC
- SVPB
- SVPD
- SVPS
- SVPE
- SVQP
- SVP
- SEK
- SEF
- SEPG
- SXE
- SEPF
- SEPC
- SEQP
- SEP

Catalog EOL models

Hybrid

Guidelines and Precautions
Mounting specifications
Packing specifications

Selection guide

Surface mount type

Radial lead type



High voltage (50 V max.)

Guaranteed at 125 °C 1000 h

RoHS compliance, Halogen free

SP-Cap

Guidelines and Precautions
Mounting specifications
Packing specifications

Selection guide

Surface mount type

Catalog EOL models

POSCAP

Guidelines and Precautions
Mounting specifications
Packing specifications

Selection guide

Surface mount type

Catalog Deletion models

Catalog EOL models

OS-CON

Guidelines and Precautions
Mounting specifications
Packing specifications

Line-up

Series system diagram
Size chart

Selection guide

Products list

- SVT
- SVPT
- SVF
- SVPK**
- SXV
- SVPG
- SVPF
- SVPA
- SVPC
- SVPB
- SVPD
- SVPS
- SVPE
- SVQP
- SVP
- SEK
- SEF
- SEPG
- SXE
- SEPF
- SEPC
- SEQP
- SEP

Surface mount type

Radial lead type

Catalog EOL models

Hybrid

Guidelines and Precautions
Mounting specifications
Packing specifications

Selection guide

Surface mount type

Radial lead type

Specifications

Items	Specifications				
	B6	C6	E7	E12	F12
Size code	B6	C6	E7	E12	F12
Category temperature range	-55 °C to +125 °C				
Rated voltage range	16 V to 50 V				
Rated capacitance range	10 μF tp 100 μF	22 μF to 220 μF	33 μF to 330 μF	68 μF to 680 μF	120 μF to 1200 μF
Capacitance tolerance	±20 % (120 Hz/+20 °C)				
Leakage current	Please see the attached characteristics list				
Dissipation factor(tanδ)	Please see the attached characteristics list				
Endurance	+125 °C, 1000 h, rated voltage applied				
	Capacitance change	Within ±20 % of the initial value			
	tanδ	≤ 200 % of the initial limit			
	DC leakage current	Within the initial limit			
Damp heat(Steady state)	+60 °C, 90 % to 95 % RH, 1000 h, No-applied voltage				
	Capacitance change	Within ±20 % of the initial value			
	tanδ	≤ 150 % of the initial limit			
	DC leakage current	Within the initial limit (after voltage processing)			

Marking and Dimensions

※ Depends on the case size.

Size code	(unit : mm)						
	φD ±0.5	L ^{+0.1} / _{-0.4}	W ±0.2	H ±0.2	C ±0.2	R	P ※1
B6	5.0	5.9	5.3	5.3	6.0	0.6 to 0.8	1.4
C6	6.3	5.9	6.6	6.6	7.3	0.6 to 0.8	2.1
E7	8.0	6.9	8.3	8.3	9.0	0.6 to 0.8	3.2
E12	8.0	11.9	8.3	8.3	9.0	0.8 to 1.1	3.2
F12	10.0	12.6	10.3	10.3	11.0	0.8 to 1.1	4.6

※1 Reference

Characteristics list												
Series	Rated voltage (V)	Rated capacitance (μF)	Case size (mm)		Size code	Specifications					Standard (Reel size: φ 380)	
			φD	L		Ripple current ※1 (mA rms)	Allowable ripple current ※1 (mA rms)	ESR ※2 (mΩ max.)	tan δ ※3	LC ※4 (μA)	Part number	Min. Packaging Qty (pcs)
SVPK	16	100	5.0	5.9	B6	940	3000	27	0.12	320	16SVPK100M	1500
		220	6.3	5.9	C6	1040	3300	22	0.12	704	16SVPK220M	1000
		330	8.0	6.9	E7	1040	3300	22	0.12	1056	16SVPK330M	1000
		680	8.0	11.9	E12	1560	4950	14	0.12	2176	16SVPK680M	400
		1200	10.0	12.6	F12	1700	5400	12	0.12	3840	16SVPK1200M	400
	20	68	5.0	5.9	B6	880	2800	30	0.12	272	20SVPK68M	1500
		150	6.3	5.9	C6	1010	3200	25	0.12	600	20SVPK150M	1000
		220	8.0	6.9	E7	1010	3200	25	0.12	880	20SVPK220M	1000
		470	8.0	11.9	E12	1560	4950	14	0.12	1880	20SVPK470M	400
		680	10.0	12.6	F12	1700	5400	12	0.12	2720	20SVPK680M	400
	25	33	5.0	5.9	B6	820	2600	35	0.12	165	25SVPK33M	1500
		82	6.3	5.9	C6	960	3060	25	0.12	410	25SVPK82M	1000
		120	8.0	6.9	E7	1010	3200	24	0.12	600	25SVPK120M	1000
		270	8.0	11.9	E12	1470	4650	16	0.12	1350	25SVPK270M	400
		470	10.0	12.6	F12	1590	5000	14	0.12	2350	25SVPK470M	400
	35	22	5.0	5.9	B6	820	2600	35	0.12	154	35SVPK22M	1500
		47	6.3	5.9	C6	930	2950	27	0.12	329	35SVPK47M	1000
		82	8.0	6.9	E7	960	3060	25	0.12	574	35SVPK82M	1000
		180	8.0	11.9	E12	1260	4000	20	0.12	1260	35SVPK180M	400
		330	10.0	12.6	F12	1390	4400	18	0.12	2310	35SVPK330M	400
50	10	5.0	5.9	B6	550	1750	80	0.12	100	50SVPK10M	1500	
	22	6.3	5.9	C6	820	2600	35	0.12	220	50SVPK22M	1000	
	33	8.0	6.9	E7	850	2700	35	0.12	330	50SVPK33M	1000	
	68	8.0	11.9	E12	1200	3800	25	0.12	680	50SVPK68M	400	
	120	10.0	12.6	F12	1350	4300	20	0.12	1200	50SVPK120M	400	

※1: Ripple current (100 kHz/ +105 °C < Tx ≤ +125 °C) / Allowable ripple current (100 kHz/ Tx ≤ +105 °C)
 ※2: ESR (100 kHz to 300 kHz/+20 °C)
 ※3: tan δ (120 Hz/+20 °C)
 ※4: After 2 minutes
 ◆Please refer to each page in this catalog for "Reflow conditions" and "Taping specifications"

Frequency correction factor for ripple current				
Frequency	120 Hz ≤ f < 1 kHz	1 kHz ≤ f < 10 kHz	10 kHz ≤ f < 100 kHz	100 kHz ≤ f ≤ 500 kHz
Coefficient	0.05	0.3	0.7	1

Guidelines and Precautions
 Mounting specifications
 Packing specifications

Selection guide

Surface mount type

Catalog EOL models

POSCAP

Guidelines and Precautions
 Mounting specifications
 Packing specifications

Selection guide

Surface mount type

Catalog Deletion models

Catalog EOL models

OS-CON

Guidelines and Precautions
 Mounting specifications
 Packing specifications

Selection guide
 Line-up
 Series system diagram
 Size chart

Products list

- SVT
- SVPT
- SVF
- SVPK**
- SXV
- SVPG
- SVPF
- SVPA
- SVPC
- SVPB
- SVPD
- SVPS
- SVPE
- SVQP
- SVP
- SEK
- SEF
- SEPG
- SXE
- SEPF
- SEPC
- SEQP
- SEP

Catalog EOL models

Hybrid

Guidelines and Precautions
 Mounting specifications
 Packing specifications

Selection guide

Surface mount type

Radial lead type



Super high voltage(100 V max.)

Guaranteed at 125 °C 1000 h

RoHS compliance, Halogen free

SP-Cap

Guidelines and Precautions
Mounting specifications
Packing specifications

Selection guide

Surface mount type

POSCAP

Guidelines and Precautions
Mounting specifications
Packing specifications

Selection guide

Surface mount type

Catalog Deletion models
Catalog EOL models

OS-CON

Guidelines and Precautions
Mounting specifications
Packing specifications

Line-up
Series system diagram
Size chart
Selection guide

Products list

- SVT
- SVPT
- SVF
- SVPK
- SXV**
- SVPG
- SVPF
- SVPA
- SVPC
- SVPB
- SVPD
- SVPS
- SVPE
- SVQP
- SVP
- SEK
- SEF
- SEPG
- SXE
- SEPF
- SEPC
- SEQP
- SEP

Catalog EOL models

Hybrid

Guidelines and Precautions
Mounting specifications
Packing specifications

Selection guide

Surface mount type

Radial lead type

Specifications

Items	Specifications			
	E7	E12	F8	F12
Size code	E7	E12	F8	F12
Category temperature range	-55 °C to +125 °C			
Rated voltage range	63 V to 100 V			
Rated capacitance range	6.8 μF to 18 μF	15 μF to 56 μF	15 μF to 39 μF	18 μF to 100 μF
Capacitance tolerance	±20 % (120 Hz/+20 °C)			
Leakage current	Please see the attached characteristics list			
Dissipation factor(tanδ)	Please see the attached characteristics list			
Endurance	+125 °C, 1000 h, rated voltage applied			
	Capacitance change	Within±20 % of the initial value		
	tanδ	≤ 200 % of the initial limit		
	DC leakage current	Within the initial limit		
Damp heat(Steady state)	+60 °C, 90 % to 95 % RH, 1000 h, No-applied voltage			
	Capacitance change	Within±20 % of the initial value		
	tanδ	≤ 150 % of the initial limit		
	DC leakage current	Within the initial limit (after voltage processing)		

Marking and Dimensions

Lot No.
Series code*
R. capacitance (μF)
R. voltage (V)

0.2 max
W
H
R
L
φD
C

※ Depends on the case size.

(unit : mm)

Size code	φD ±0.5	L ^{+0.1} / _{-0.4}	W ±0.2	H ±0.2	C ±0.2	R	P ※1
E7	8.0	6.9	8.3	8.3	9.0	0.6 to 0.8	3.2
E12	8.0	11.9	8.3	8.3	9.0	0.8 to 1.1	3.2
F8	10.0	7.9	10.3	10.3	11.0	0.6 to 0.8	4.6
F12	10.0	12.6	10.3	10.3	11.0	0.8 to 1.1	4.6

※1 Reference

Characteristics list

Series	Rated voltage (V)	Rated capacitance (μF)	Case size (mm)		Size code	Specifications					Standard (Reel size: φ 380)		
			φD	L		Ripple current ※1 (mA rms)	Allowable ripple current ※1 (mA rms)	ESR ※2 (mΩ max.)	tan δ ※3	LC ※4 (μA)	Part number	Min. Packaging Qty (pcs)	
SXV	63	18	8.0	6.9	E7	340	1100	60	0.12	56	63SXV18M	1000	
													E12
		39	8.0	11.9	930	2950	25	0.12	122	63SXV39M	400		
												F8	
		E12	56	8.0	11.9	930	2950	25	0.12	176	63SXV56M		
												F12	
		F12	100	10.0	12.6	1030	3280	25	0.12	315	63SXV100M		
												80	
		E12	27	8.0	11.9	780	2490	35	0.12	108	80SXV27M		400
	F8												
		E12	33	8.0	11.9	780	2490	35	0.12	132	80SXV33M		400
	F12												
		F12	56	10.0	12.6	980	3100	28	0.12	224	80SXV56M		400
	100												
		F8	15	10.0	7.9	630	2000	60	0.12	75	100SXV15MX		500
		F12	18	10.0	12.6	940	3000	30	0.12	90	100SXV18M	400	
													F12
F12		27	10.0	12.6	940	3000	30	0.12	135	100SXV27M	400		

※1: Ripple current (100 kHz/ +105 °C < Tx ≤ 125 °C), Allowable ripple current (100 kHz / Tx ≤ 105 °C) ※2: ESR (100 kHz to 300 kHz/+20 °C)

※3: tan δ (120 Hz/+20 °C) ※4: After 2 minutes

◆Please refer to each page in this catalog for "Reflow conditions" and "Taping specifications"

Frequency correction factor for ripple current

Frequency	120 Hz ≤ f < 1 kHz	1 kHz ≤ f < 10 kHz	10 kHz ≤ f < 100 kHz	100 kHz ≤ f ≤ 500 kHz
Coefficient	0.05	0.3	0.7	1



- Low profile (Height 4.5 mm max.)
- High ripple (7500 mA rms max.)
- Low ESR (6.5 mΩ max.)
- RoHS compliance, Halogen free

Specifications											
Items	Specifications										
Size code	B45	B6	C6	C8	C10	C10L	E7	E10	E12	F10	F12
Category temperature range	-55 °C to +105 °C										
Rated voltage range	16 V to 25 V		16 V								
Rated capacitance range	15 μF to 47 μF	100 μF	220 μF	270 μF	330 μF	560 μF	680 μF	820 μF	1200 μF		
Capacitance tolerance	±20 % (120 Hz/+20 °C)										
Leakage current	Please see the attached characteristics list										
Dissipation factor (tanδ)	Please see the attached characteristics list										
Endurance	+105 °C, 5000 h, rated voltage applied										
	Capacitance change	Within ±20 % of the initial value									
	tanδ	≤ 150 % of the initial limit									
Damp heat (Steady state)	+60 °C, 90 % to 95 % RH, 1000 h, No-applied voltage										
	Capacitance change	Within ±20 % of the initial value									
	tanδ	≤ 150 % of the initial limit									
DC leakage current	Within the initial limit										
	Within the initial limit (after voltage processing)										

Marking and Dimensions								
(unit : mm)								
<p>※ Depends on the case size.</p>	Size code	φD ±0.5	L ^{+0.1} / _{-0.4}	W ±0.2	H ±0.2	C ±0.2	R	P ※2
	B45	5.0	4.4	5.3	5.3	6.0	0.6 to 0.8	1.4
	B6	5.0	5.9	5.3	5.3	6.0	0.6 to 0.8	1.4
	C6	6.3	5.9	6.6	6.6	7.3	0.6 to 0.8	2.1
	C8	6.3	7.9	6.6	6.6	7.3	0.6 to 0.8	2.1
	C10	6.3	9.9	6.6	6.6	7.3	0.6 to 0.8	2.1
	C10L	6.3	10.4	6.6	6.6	7.3	1.5 to 1.8	2.1
	E7	8.0	6.9	8.3	8.3	9.0	0.6 to 0.8	3.2
	E10	8.0	10.0※1	8.3	8.3	9.0	0.8 to 1.1	3.2
	E12	8.0	11.9	8.3	8.3	9.0	0.8 to 1.1	3.2
	F10	10.0	10.0※1	10.3	10.3	11.0	0.8 to 1.1	4.6
	F12	10.0	12.6	10.3	10.3	11.0	0.8 to 1.1	4.6
		※1 : ±0.5		※2 Reference				

Characteristics list											
Series	Rated voltage (V)	Rated capacitance (μF)	Case size (mm)		Size code	Specifications				Standard (Reel size: φ 380)	
			φD	L		Ripple current ※1 (mA r.m.s.)	ESR ※2 (mΩ max.)	tan δ ※3	LC ※4 (μA)	Part number	Min. Packaging Qty (pcs)
SVPG	16	47	5.0	4.4	B45	3200	25	0.12	150	16SVPG47M	2500
		100	5.0	5.9	B6	4000	15	0.12	320	16SVPG100M	1500
		220	6.3	5.9	C6	4100	14	0.12	704	16SVPG220M	1000
			6.3	7.9	C8	5080	10	0.12	864	16SVPG270MX	900
		270	6.3	9.9	C10	5800	8	0.12	864	16SVPG270M	500
			6.3	10.4	C10L	7500	6.5	0.12	1056	16SVPG330M	700
		330	8.0	6.9	E7	4100	16	0.12	1056	16SVPG330MX	1000
			560	8.0	10.0	E10	5200	10	0.12	1792	16SVPG560M
		680	8.0	11.9	E12	6500	8	0.12	2176	16SVPG680M	400
		820	10.0	10.0	F10	5700	9	0.12	2624	16SVPG820M	500
	1200	10.0	12.6	F12	7000	7	0.12	3840	16SVPG1200M	400	
	20	33	5.0	4.4	B45	3000	27	0.12	132	20SVPG33M	2500
	25	15	5.0	4.4		2800	30	0.12	75	25SVPG15M	2500

※1: Rated ripple current (100 kHz/ +105 °C) ※2: ESR (100 kHz to 300 kHz/+20 °C) ※3: tanδ (120 Hz/+20 °C) ※4: After 2 minutes
 ◆ Please refer to each page in this catalog for "Reflow conditions" and "Taping specifications"

Frequency correction factor for ripple current				
Frequency	120 Hz ≤ f < 1 kHz	1 kHz ≤ f < 10 kHz	10 kHz ≤ f < 100 kHz	100 kHz ≤ f ≤ 500 kHz
Coefficient	0.05	0.3	0.7	1

SP-Cap
 Guidelines and Precautions
 Mounting specifications
 Packing specifications
 Selection guide

Surface mount type

Catalog EOL models

POSCAP
 Guidelines and Precautions
 Mounting specifications
 Packing specifications
 Selection guide

Surface mount type

Catalog Deletion models
 Catalog EOL models

OS-CON
 Guidelines and Precautions
 Mounting specifications
 Packing specifications
 Selection guide
 Series system diagram
 Size chart
Products list
 SVT
 SVPT
 SVF
 SVPK
 SXV
SVPG
 SVPF
 SVPA
 SVPC
 SVPB
 SVPD
 SVPS
 SVPE
 SVQP
 SVP
 SEK
 SEF
 SEPG
 SXE
 SEPF
 SEPC
 SEQP
 SEP

Surface mount type

Radial lead type

Catalog EOL models

Hybrid
 Guidelines and Precautions
 Mounting specifications
 Packing specifications
 Selection guide

Surface mount type

Radial lead type



High voltage (50 V max.)

Large capacitance (1000 μF max.)

Guaranteed at 105 °C 5000 h

RoHS compliance, Halogen free

SP-Cap

Guidelines and Precautions
Mounting specifications
Packing specifications

Selection guide

Surface mount type

Catalog EOL models

POSCAP

Guidelines and Precautions
Mounting specifications
Packing specifications

Selection guide

Surface mount type

Catalog Deletion models

Catalog EOL models

OS-CON

Guidelines and Precautions
Mounting specifications
Packing specifications

Line-up

Series system diagram
Size chart

Products list

- SVT
- SVPT
- SVF
- SVPK
- SXV
- SVPG
- SVPF**
- SVPA
- SVPC
- SVPB
- SVPD
- SVPS
- SVPE
- SVQP
- SVP
- SEK
- SEF
- SEPG
- SXE
- SEPF
- SEPC
- SEQP
- SEP

Catalog EOL models

Hybrid

Guidelines and Precautions
Mounting specifications
Packing specifications

Selection guide

Surface mount type

Radial lead type

Specifications

Items	Specifications						
	B6	C6	E7	E10	E12	F10	F12
Size code	B6	C6	E7	E10	E12	F10	F12
Category temperature range	-55 °C to +105 °C						
Rated voltage range	16 V to 25 V	16 V to 50 V		16 V	16 V to 50 V	16 V	16 V to 50 V
Rated capacitance range	27 μF to 82 μF	10 μF to 180 μF	18 μF to 270 μF	560 μF	39 μF to 560 μF	1000 μF	68 μF to 1000 μF
Capacitance tolerance	±20 % (120 Hz/+20 °C)						
Leakage current	Please see the attached characteristics list						
Dissipation factor(tanδ)	Please see the attached characteristics list						
Endurance	+105 °C, 5000 h, rated voltage applied						
	Capacitance change	Within±20 % of the initial value					
	tanδ	≤ 150 % of the initial limit					
	DC leakage current	Within the initial limit					
Damp heat(Steady state)	+60 °C, 90 % to 95 % RH, 1000 h, No-applied voltage						
	Capacitance change	Within±20 % of the initial value					
	tanδ	≤ 150 % of the initial limit					
	DC leakage current	Within the initial limit (after voltage processing)					

Marking and Dimensions

※ Depends on the case size.

Size code	φD ±0.5	L ^{+0.1} / _{-0.4}	W ±0.2	H ±0.2	C ±0.2	R	P ※2
B6	5.0	5.9	5.3	5.3	6.0	0.6 to 0.8	1.4
C6	6.3	5.9	6.6	6.6	7.3	0.6 to 0.8	2.1
E7	8.0	6.9	8.3	8.3	9.0	0.6 to 0.8	3.2
E10	8.0	10.0※1	8.3	8.3	9.0	0.8 to 1.1	3.2
E12	8.0	11.9	8.3	8.3	9.0	0.8 to 1.1	3.2
F10	10.0	10.0※1	10.3	10.3	11.0	0.8 to 1.1	4.6
F12	10.0	12.6	10.3	10.3	11.0	0.8 to 1.1	4.6

※1:±0.5 ※2: Reference

Characteristics list

Series	Rated voltage (V)	Rated capacitance (μF)	Case size (mm)		Size code	Specifications				Standard (Reel size: φ 380)	
			φD	L		Ripple current ※1 (mA rms)	ESR ※2 (mΩ max.)	tan δ ※3	LC ※4 (μA)	Part number	Min. Packaging Qty (pcs)
SVPF	16	82	5.0	5.9	B6	3000	27	0.12	262	16SVPF82M	1500
		180	6.3	5.9	C6	3300	22	0.12	576	16SVPF180M	1000
		270	8.0	6.9	E7	3300	22	0.12	864	16SVPF270M	1000
		560	8.0	10.0	E10	3900	18	0.12	1792	16SVPF560MX	500
			8.0	11.9	E12	4950	14	0.12	1792	16SVPF560M	400
		1000	10.0	10.0	F10	4300	16	0.12	3200	16SVPF1000MX	500
	10.0		12.6	F12	5400	12	0.12	3200	16SVPF1000M	400	
	20	56	5.0	5.9	B6	2800	30	0.12	224	20SVPF56MX	1500
		120	6.3	5.9	C6	3200	25	0.12	480	20SVPF120M	1000
		180	8.0	6.9	E7	3200	25	0.12	720	20SVPF180M	1000
		390	8.0	11.9	E12	4950	14	0.12	1560	20SVPF390M	400
		560	10.0	12.6	F12	5400	12	0.12	2240	20SVPF560M	400
			27	5.0	5.9	B6	2450	40	0.12	135	25SVPF27MX
	25	47	6.3	5.9	C6	2800	30	0.12	235	25SVPF47M	1000
		56	6.3	5.9		2800	30	0.12	280	25SVPF56M	1000
		82	8.0	6.9		E7	3000	28	0.12	410	25SVPF82M
		100	8.0	6.9	E7	3200	24	0.12	500	25SVPF100M	1000
		180	8.0	11.9	E12	4650	16	0.12	900	25SVPF180M	400
		330	10.0	12.6	F12	5000	14	0.12	1650	25SVPF330M	400
	35	22	6.3	5.9	C6	2600	35	0.12	154	35SVPF22M	1000
		39	8.0	6.9	E7	2800	30	0.12	273	35SVPF39M	1000
		82	8.0	11.9	E12	4000	20	0.12	574	35SVPF82M	400
		120	10.0	12.6	F12	4400	18	0.12	840	35SVPF120M	400
		10	6.3	5.9	C6	2500	40	0.12	100	50SVPF10M	1000
18		8.0	6.9	E7	2700	35	0.12	180	50SVPF18M	1000	
50	39	8.0	11.9	E12	3800	25	0.12	390	50SVPF39M	400	
	68	10.0	12.6	F12	4300	20	0.12	680	50SVPF68M	400	

※1:Rated ripple current(100 kHz/+105 °C) ※2:ESR (100 kHz to 300 kHz/+20 °C) ※3:tanδ (120 Hz/+20 °C) ※4:After 2 minutes

◆Please refer to each page in this catalog for "Reflow conditions" and "Taping specifications"

Frequency correction factor for ripple current

Frequency	120 Hz ≤ f < 1 kHz	1 kHz ≤ f < 10 kHz	10 kHz ≤ f < 100 kHz	100 kHz ≤ f ≤ 500 kHz
Coefficient	0.05	0.3	0.7	1



Low ESR (19 mΩ max.)

High ripple (4240 mA rms max.)

RoHS compliance, Halogen free

Specifications

Items	Specifications			
	B6	C6	E7	F8
Size code	B6	C6	E7	F8
Category temperature range	-55 °C to +105 °C			
Rated voltage range	2.5 V to 20 V			2.5 V to 16 V
Rated capacitance range	10 μF to 82 μF	22 μF to 180 μF	47 μF to 330 μF	180 μF to 820 μF
Capacitance tolerance	±20 % (120 Hz/+20 °C)			
Leakage current	Please see the attached characteristics list			
Dissipation factor(tanδ)	Please see the attached characteristics list			
Endurance	+105 °C, 2000 h, rated voltage applied			
	Capacitance change	Within ±20 % of the initial value		
	tanδ	≤ 150 % of the initial limit		
	DC leakage current	Within the initial limit		
Damp heat (Steady state)	+60 °C, 90 % to 95 % RH, 1000 h, No-applied voltage			
	Capacitance change	Within ±20 % of the initial value		
	tanδ	≤ 150 % of the initial limit		
	DC leakage current	Within the initial limit (after voltage processing)		

Marking and Dimensions

※ Depends on the case size.

Size code	φD ±0.5	L ^{+0.1} / _{-0.4}	W ±0.2	H ±0.2	C ±0.2	R	P ※1
B6	5.0	5.9	5.3	5.3	6.0	0.6 to 0.8	1.4
C6	6.3	5.9	6.6	6.6	7.3	0.6 to 0.8	2.1
E7	8.0	6.9	8.3	8.3	9.0	0.6 to 0.8	3.2
F8	10.0	7.9	10.3	10.3	11.0	0.6 to 0.8	4.6

(unit : mm)

※1 Reference

Characteristics list

Series	Rated voltage (V)	Rated capacitance (μF)	Case size (mm)		Size code	Specifications				Standard (Reel size: φ 380)	
			φD	L		Ripple current ※1 (mA rms)	ESR ※2 (mΩ max.)	tan δ ※3	LC ※4 (μA)	Part number	Min. Packaging Qty (pcs)
SVPA	2.5	82	5.0	5.9	B6	1970	30	0.12	300	2R5SVPA82MAA	1500
		180	6.3	5.9	C6	2690	20	0.12	300	2R5SVPA180MAA	1000
		330	8.0	6.9	E7	3370	20	0.12	500	2R5SVPA330MAA	1000
		820	10.0	7.9	F8	4240	19	0.12	500	2R5SVPA820M	500
	4	68	5.0	5.9	B6	1970	30	0.12	300	4SVPA68MAA	1500
		150	6.3	5.9	C6	2570	22	0.12	300	4SVPA150MAA	1000
		270	8.0	6.9	E7	3220	22	0.12	500	4SVPA270MAA	1000
		680	10.0	7.9	F8	4130	20	0.12	544	4SVPA680M	500
	6.3	47	5.0	5.9	B6	1970	30	0.12	300	6SVPA47MAA	1500
		120	6.3	5.9	C6	2570	22	0.12	300	6SVPA120MAA	1000
		220	8.0	6.9	E7	3220	22	0.12	500	6SVPA220MAA	1000
		470	10.0	7.9	F8	4130	20	0.12	592	6SVPA470M	500
	10	68	6.3	5.9	C6	2200	30	0.12	300	10SVPA68MAA	1000
		150	8.0	6.9	E7	2760	30	0.12	500	10SVPA150MAA	1000
		330	10.0	7.9	F8	3770	24	0.12	660	10SVPA330M	500
	16	39	6.3	5.9	C6	2040	35	0.12	300	16SVPA39MAA	1000
			6.3	5.9		2460	24	0.12	300	16SVPA39MAAY	1000
		82	8.0	6.9	E7	2760	30	0.12	262	16SVPA82MAA	1000
			180	10.0	7.9	F8	3430	29	0.12	576	16SVPA180M
	20	10	5.0	5.9	B6	1700	40	0.12	80	20SVPA10M	1500
22		6.3	5.9	C6	2040	35	0.12	88	20SVPA22M	1000	
47		8.0	6.9	E7	2630	33	0.12	188	20SVPA47M	1000	

※1: Ripple current (100 kHz/ +105 °C) ※2: ESR (100 Hz/+20 °C) ※3: tan δ (120 Hz/+20 °C) ※4: After 2 minutes

◆Please refer to each page in this catalog for "Reflow conditions" and "Taping specifications"

Frequency correction factor for ripple current

Frequency	120 Hz ≤ f < 1 kHz	1 kHz ≤ f < 10 kHz	10 kHz ≤ f < 100 kHz	100 kHz ≤ f ≤ 500 kHz
Coefficient	0.05	0.3	0.7	1

SP-Cap

Guidelines and Precautions
Mounting specifications
Packaging specifications

Selection guide

Surface mount type

Catalog EOL models

POSCAP

Guidelines and Precautions
Mounting specifications
Packaging specifications

Selection guide

Surface mount type

Catalog Deletion models

Catalog EOL models

OSCON

Guidelines and Precautions
Mounting specifications
Packaging specifications

Selection guide
Line-up
Series system diagram
Size chart

Products list

- SVT
- SVPT
- SVF
- SVPK
- SXV
- SVPG
- SVPF
- SVPA**
- SVPC
- SVPB
- SVPD
- SVPS
- SVPE
- SVQP
- SVP

Surface mount type

Radial lead type

Catalog EOL models

Hybrid

Guidelines and Precautions
Mounting specifications
Packaging specifications

Selection guide

Surface mount type

Radial lead type



Low ESR (9 mΩ max.)

Large capacitance (2700 μF max.)

RoHS compliance, Halogen free

SP-Cap

Guidelines and Precautions
Mounting specifications
Packing specifications

Selection guide

Surface mount type

Catalog EOL models

POSCAP

Guidelines and Precautions
Mounting specifications
Packing specifications

Selection guide

Surface mount type

Catalog Deletion models

Catalog EOL models

OS-CON

Guidelines and Precautions
Mounting specifications
Packing specifications

Line-up
Series system diagram
Size chart

Products list

SVT

SVPT

SVF

SVPK

SXV

SVPG

SVPF

SVPA

SVPC

SVPB

SVPD

SVPS

SVPE

SVQP

SVP

SEK

SEF

SEPG

SXE

SEPF

SEPC

SEQP

SEP

Surface mount type

Radial lead type

Catalog EOL models

Hybrid

Guidelines and Precautions
Mounting specifications
Packing specifications

Selection guide

Surface mount type

Radial lead type

Specifications

Items	Specifications				
	Size code	B6	C6	E7	E12
Category temperature range	-55 °C to +105 °C				
Rated voltage range	2.5 V to 16 V				2.5 V
Rated capacitance range	39 μF to 180 μF	68 μF to 560 μF	120 μF to 680 μF	270 μF to 1500 μF	2700 μF
Capacitance tolerance	±20 % (120 Hz/+20 °C)				
Leakage current	Please see the attached characteristics list				
Dissipation factor (tanδ)	Please see the attached characteristics list				
Endurance	+105 °C, 2000 h, rated voltage applied				
	Capacitance change	Within ±20 % of the initial value			
	tanδ	≤ 150 % of the initial limit			
	DC leakage current	Within the initial limit			
Damp heat (Steady state)	+60 °C, 90 % to 95 % RH, 1000 h, No-applied voltage				
	Capacitance change	Within ±20 % of the initial value			
	tanδ	≤ 150 % times of the initial limit			
	DC leakage current	Within the initial limit (after voltage processing)			

Marking and Dimensions

Lot No

Series code*

R. capacitance (μF)

R. voltage (V)

0.2 max

(-)

(+)

φD

L

W

H

C

R

(unit : mm)

Size code	φD ±0.5	L ^{+0.1} / _{-0.4}	W ±0.2	H ±0.2	C ±0.2	R	P ※1
B6	5.0	5.9	5.3	5.3	6.0	0.6 to 0.8	1.4
C6	6.3	5.9	6.6	6.6	7.3	0.6 to 0.8	2.1
E7	8.0	6.9	8.3	8.3	9.0	0.6 to 0.8	3.2
E12	8.0	11.9	8.3	8.3	9.0	0.8 to 1.1	3.2
F12	10.0	12.6	10.3	10.3	11.0	0.8 to 1.1	4.6

※1 Reference

※ Depends on the case size.

Characteristics list

Series	Rated voltage (V)	Rated capacitance (μF)	Case size (mm)		Size code	Specifications					Standard (Reel size: φ 380)	
			φD	L		Ripple current ※1 (mA rms)	ESR		tan δ ※2	LC ※3 (μA)	Part number	Min. Packaging Qty (pcs)
							100 kHz/20 °C (mΩ max.)	300 kHz/20 °C (mΩ max.)				
SVPC	2.5	180	5.0	5.9	B6	1970	30	26	0.12	300	2R5SVPC180M	1500
			5.0	5.9		2200	24	20	0.12	300	2R5SVPC180MY	1500
			5.0	5.9		2800	19	16	0.12	300	2R5SVPC180MV	1500
		390	6.3	5.9	C6	2410	25	22	0.12	300	2R5SVPC390M	1000
			6.3	5.9		3160	15	13	0.12	300	2R5SVPC390MV	1000
			6.3	5.9		3500	16	14	0.12	300	2R5SVPC560M	1000
		680	8.0	6.9	E7	3370	20	17	0.12	500	2R5SVPC680M	1000
			8.0	11.9	E12	5380	9	8	0.15	500	2R5SVPC820M	400
		1500	8.0	11.9		5150	10	9	0.15	750	2R5SVPC1500M	400
	2700	10.0	12.6	F12	5070	12	10	0.15	1350	2R5SVPC2700M	400	
	4.0	150	5.0	5.9	B6	1970	30	26	0.12	300	4SVPC150M	1500
			5.0	5.9		2240	23	20	0.12	300	4SVPC150MY	1500
			5.0	5.9		2730	20	17	0.12	300	4SVPC150MV	1500
		330	6.3	5.9	C6	2320	27	23	0.12	300	4SVPC330M	1000
			6.3	5.9		2630	21	18	0.12	300	4SVPC330MY	1000
			6.3	5.9		3160	15	13	0.12	300	4SVPC330MV	1000
		560	8.0	6.9	E7	3220	22	19	0.12	500	4SVPC560M	1000
			8.0	11.9	E12	5380	9	8	0.15	500	4SVPC560MX	400
			1200	8.0		11.9	4700	12	10	0.15	960	4SVPC1200M
	1500	8.0	11.9	4700	12	10	0.15	1200	4SVPC1500M	400		
	6.3	100	5.0	5.9	B6	1970	30	26	0.12	300	6SVPC100M	1500
			5.0	5.9		2150	25	21	0.12	300	6SVPC100MY	1500
		120	5.0	5.9	C6	2660	21	18	0.12	300	6SVPC120MV	1500
		220	6.3	5.9		2320	27	23	0.12	300	6SVPC220M	1000
			6.3	5.9		3160	15	13	0.12	300	6SVPC220MV	1000
		330	6.3	5.9	3390	17	15	0.12	415	6SVPC330M	1000	
		390	8.0	6.9	E7	3220	22	19	0.12	491	6SVPC390M	1000
		820	8.0	11.9	E12	4700	12	10	0.15	1033	6SVPC820M	400
10		68	5.0	5.9	B6	1970	30	26	0.12	300	10SVPC68M	1500
	5.0		5.9	2540		23	20	0.12	300	10SVPC68MV	1500	
	120	6.3	5.9	C6	2320	27	23	0.12	300	10SVPC120M	1000	
		6.3	5.9		2600	22	19	0.12	300	10SVPC120MV	1000	
	270	8.0	6.9	E7	3220	22	19	0.12	500	10SVPC270M	1000	
330	8.0	6.9	3460	19	17	0.12	660	10SVPC330M	1000			
16	39	5.0	5.9	B6	1820	35	30	0.12	300	16SVPC39M	1500	
		5.0	5.9		2350	27	23	0.12	300	16SVPC39MV	1500	
	68	6.3	5.9	C6	2200	30	26	0.12	300	16SVPC68M	1000	
		6.3	5.9		2440	25	22	0.12	300	16SVPC68MV	1000	
	100	6.3	5.9	2490	24	23	0.12	300	16SVPC100M	1000		
	120	8.0	6.9	E7	2900	27	23	0.12	500	16SVPC120M	1000	
150	8.0	6.9	3220	22	21	0.12	500	16SVPC150M	1000			
270	8.0	11.9	E12	4070	16	14	0.15	864	16SVPC270M	400		

※1: Rated ripple current (100 kHz/ +105 °C)

※2: tan δ (120 Hz/+20 °C)

※3: After 2 minutes

◆Please refer to each page in this catalog for "Reflow conditions" and "Taping specifications"

Frequency correction factor for ripple current

Frequency	120 Hz ≤ f < 1 kHz	1 kHz ≤ f < 10 kHz	10 kHz ≤ f < 100 kHz	100 kHz ≤ f ≤ 500 kHz
Coefficient	0.05	0.3	0.7	1

SP-Cap

Guidelines and Precautions
Mounting specifications
Packing specifications

Selection guide

Surface mount type

Catalog EOL models

POSCAP

Guidelines and Precautions
Mounting specifications
Packing specifications

Selection guide

Surface mount type

Catalog Deletion models

Catalog EOL models

OS-CON

Guidelines and Precautions
Mounting specifications
Packing specifications

Selection guide
Line-up
Series system diagram
Size chart

Products list

SVT
SVPT
SVF
SVPK
SXV
SVPG
SVPF
SVPA
SVPC
SVPB
SVPD
SVPS
SVPE
SVQP
SVP
SEK
SEF
SEPG
SXE
SEPF
SEPC
SEQP
SEP

Catalog EOL models

Hybrid

Guidelines and Precautions
Mounting specifications
Packing specifications

Selection guide

Surface mount type

Radial lead type



Low profile (Height 5 mm max.)

RoHS compliance, Halogen free

SP-Cap

Guidelines and Precautions
Mounting specifications
Packing specifications

Selection guide

Surface mount type

Catalog EOL models

POSCAP

Guidelines and Precautions
Mounting specifications
Packing specifications

Selection guide

Surface mount type

Catalog Deletion models

Catalog EOL models

OS-CON

Guidelines and Precautions
Mounting specifications
Packing specifications

Line-up

Series system diagram
Size chart

Products list

SVT

SVPT

SVF

SVPK

SXV

SVPG

SVPF

SVPA

SVPC

SVPB

SVPD

SVPS

SVPE

SVQP

SVP

SEK

SEF

SEPG

SXE

SEPF

SEPC

SEQP

SEP

Catalog EOL models

Hybrid

Guidelines and Precautions
Mounting specifications
Packing specifications

Selection guide

Surface mount type

Radial lead type

Specifications

Items	Specifications	
Size code	C5	C55
Category temperature range	-55 °C to +105 °C	
Rated voltage range	2.5 V to 20 V	20 V
Rated capacitance range	15 μF to 120 μF	22 μF
Capacitance tolerance	±20(120 Hz/+20 °C)	
Leakage current	Please see the attached characteristics list	
Dissipation factor(tanδ)	Please see the attached characteristics list	
Endurance	+105 °C, 1000 h, rated voltage applied	
	Capacitance change	Within ±20 % of the initial value (±30 % for C5 size)
	tanδ	≤ 150 % of the initial limit
	DC leakage current	Within the initial limit
Damp heat(Steady state)	+60 °C, 90 % to 95 % RH, 1000 h, No-applied voltage	
	Capacitance change	Within ±20 % of the initial value
	tanδ	≤ 150 % of the initial limit
	DC leakage current	Within the initial limit (after voltage processing)

Marking and Dimensions

Lot No

Series code*

R. capacitance (μF)

R. voltage (V)

Size code	φD ±0.5	L ^{+0.1} / _{-0.4}	W ±0.2	H ±0.2	C ±0.2	R	P ※1
C5	6.3	4.9	6.6	6.6	7.3	0.6 to 0.8	2.1
C55	6.3	5.4	6.6	6.6	7.3	0.6 to 0.8	2.1

※1 Reference

(unit : mm)

※ Depends on the case size.

Characteristics list

Series	Rated voltage (V)	Rated capacitance (μF)	Case size (mm)		Size code	Specifications				Standard (Reel size: φ 380)	
			φD	L		Ripple current ※1 (mA rms)	ESR ※2 (mΩ max.)	tan δ ※3	LC ※4 (μA)	Part number	Min. Packaging Qty (pcs)
SVPB	2.5	120	6.3	4.9	C5	1670	40	0.12	120	2R5SVPB120M	1300
	4	100	6.3	4.9		1670	40	0.12	160	4SVPB100M	1300
	6.3	82	6.3	4.9		1670	40	0.12	207	6SVPB82M	1300
	10	56	6.3	4.9		1670	40	0.12	224	10SVPB56M	1300
	16	33	6.3	4.9		1670	40	0.12	211	16SVPB33M	1300
	20	15	6.3	4.9		2000	45	0.12	120	20SVPB15M	1300
		22	6.3	5.4	C55	2000	35	0.12	88	20SVPB22M	1000

※1: Ripple current (100 kHz/+105 °C)

※2: ESR (100 kHz to 300 kHz/+20 °C)

※3: tan δ (120 Hz/+20 °C)

※4: After 2 minutes

◆Please refer to each page in this catalog for "Reflow conditions" and "Taping specifications".

Frequency correction factor for ripple current

Frequency	120 Hz ≤ f < 1 kHz	1 kHz ≤ f < 10 kHz	10 kHz ≤ f < 100 kHz	100 kHz ≤ f ≤ 500 kHz
Coefficient	0.05	0.3	0.7	1



Guaranteed at 125 °C 2000 h

Guaranteed at 85 °C 85 %

RoHS compliance, Halogen free

Specifications

Items	Specifications				
Size code	C6	E7	E12	F8	F12
Category temperature range	-55 °C to +125 °C				
Rated voltage range	10 V to 25 V	16 V to 35 V	25 V to 35 V		
Rated capacitance range	10 μF to 56 μF	8.2 μF to 82 μF	22 μF to 47 μF	18 μF to 39 μF	47 μF to 82 μF
Capacitance tolerance	±20(120 Hz/+20 °C)				
Leakage current	Please see the attached characteristics list				
Dissipation factor(tanδ)	Please see the attached characteristics list				
Endurance	+125 °C, 2000 h, rated voltage applied				
	Capacitance change	Within±20 % of the initial value			
	tanδ	≤ 200 % of the initial limit			
	DC leakage current	Within the initial limit			
Damp heat(Steady state)	+85 °C, 85 % to 90 % RH, 1000 h, rated voltage applied				
	Capacitance change	Within±20 % of the initial value			
	tanδ	≤ 200 % of the initial limit			
	DC leakage current	Within the initial limit(after voltage processing)			

Marking and Dimensions

※ Depends on the case size.

Size code	φD ±0.5	L ^{+0.1} / _{-0.4}	W ±0.2	H ±0.2	C ±0.2	R	P ※1
C6	6.3	5.9	6.6	6.6	7.3	0.6 to 0.8	2.1
E7	8.0	6.9	8.3	8.3	9.0	0.6 to 0.8	3.2
E12	8.0	11.9	8.3	8.3	9.0	0.8 to 1.1	3.2
F8	10.0	7.9	10.3	10.3	11.0	0.6 to 0.8	4.6
F12	10.0	12.6	10.3	10.3	11.0	0.8 to 1.1	4.6

※1 Reference

Characteristics list

Series	Rated voltage (V)	Rated capacitance (μF)	Case size (mm)		Size code	Specifications					Standard(Reel size: φ 380)	
			φD	L		Ripple current ※1 (mA rms)	Allowable ripple current ※1 (mA rms)	ESR ※2 (mΩ max.)	tan δ ※3	LC ※4 (μA)	Part number	Min. Packaging Qty (pcs)
SVPD	10	56	6.3	5.9	C6	538	1700	45	0.12	112	10SVPD56M	1000
	16	82	8.0	6.9	E7	670	2120	40	0.12	262	16SVPD82M	1000
	25	10	6.3	5.9	C6	474	1500	65	0.10	50	25SVPD10M	1000
		22	8.0	6.9	E7	580	1835	48	0.10	110	25SVPD22M	1000
		39	10.0	7.9	F8	664	2100	45	0.10	195	25SVPD39M	500
		47	8.0	11.9	E12	943	2980	30	0.12	235	25SVPD47M	400
		82	10.0	12.6	F12	1202	3800	28	0.12	410	25SVPD82M	400
	35	8.2	8.0	6.9	E7	400	1300	70	0.10	57	35SVPD8R2M	1000
		18	10.0	7.9	F8	550	1800	60	0.10	126	35SVPD18M	500
		22	8.0	11.9	E12	700	2300	50	0.12	154	35SVPD22M	400
		47	10.0	12.6	F12	1150	3650	30	0.12	329	35SVPD47M	400

※1:Rated ripple current (100 kHz/105 °C < Tx ≤ 125 °C)/ Allowable ripple current (100 kHz/ Tx ≤ 105 °C)

※2:ESR(100 kHz~300 kHz/+20 °C)

※3:tanδ(120 Hz/+20 °C) ※4:After 2 minutes

◆Please refer to each page in this catalog for "Reflow conditions" and "Taping specifications".

Frequency correction factor for ripple current

Frequency	120 Hz ≤ f < 1 kHz	1 kHz ≤ f < 10 kHz	10 kHz ≤ f < 100 kHz	100 kHz ≤ f ≤ 500 kHz
Coefficient	0.05	0.3	0.7	1

SP-Cap

Guidelines and Precautions
Mounting specifications
Packing specifications

Selection guide

Surface mount type

Catalog EOL models

POSCAP

Guidelines and Precautions
Mounting specifications
Packing specifications

Selection guide

Surface mount type

Catalog Deletion models

Catalog EOL models

OSCON

Guidelines and Precautions
Mounting specifications
Packing specifications

Selection guide
Line-up
Series system diagram
Size chart

Products list

- SVT
- SVPT
- SVF
- SVPK
- SXV
- SVPF
- SVPA
- SVPC
- SVPB
- SVPD**
- SVPS
- SVPE
- SVQP
- SVP
- SEK
- SEF
- SEPG
- SXE
- SEPF
- SEPC
- SEQP
- SEP

Catalog EOL models

Hybrid

Guidelines and Precautions
Mounting specifications
Packing specifications

Selection guide

Surface mount type

Radial lead type



Guaranteed at 105 °C 5000 h

RoHS compliance, Halogen free

SP-Cap

Guidelines and Precautions
Mounting specifications
Packing specifications

Selection guide

Surface mount type

Catalog EOL models

POSCAP

Guidelines and Precautions
Mounting specifications
Packing specifications

Selection guide

Surface mount type

Catalog Deletion models

Catalog EOL models

OS-CON

Guidelines and Precautions
Mounting specifications
Packing specifications

Line-up
Series system diagram
Size chart

Products list

- SVT
- SVPT
- SVF
- SVPK
- SXV
- SVPG
- SVPF
- SVPA
- SVPC
- SVPB
- SVPD
- SVPS**
- SVPE
- SVQP
- SVP
- SEK
- SEF
- SEPG
- SXE
- SEPF
- SEPC
- SEQP
- SEP

Surface mount type

Radial lead type

Catalog EOL models

Hybrid

Guidelines and Precautions
Mounting specifications
Packing specifications

Selection guide

Surface mount type

Radial lead type

Specifications

Items	Specifications				
Size code	A5	B6	C6	E7	F8
Category temperature range	-55 °C to +105 °C				
Rated voltage range	4 V to 10 V	4 V to 16 V	4 V to 20 V	4 V to 25 V	4 V to 16 V
Rated capacitance range	10 μF to 33 μF	22 μF to 68 μF	22 μF to 150 μF	10 μF to 270 μF	100 μF to 680 μF
Capacitance tolerance	±20 % (120 Hz/+20 °C)				
Leakage current	Please see the attached characteristics list				
Dissipation factor(tanδ)	Please see the attached characteristics list				
Endurance	+105 °C, 5000 h, rated voltage applied (25 V product : 20 V applied)				
	Capacitance change	Within ±20 % of the initial value			
	tanδ	≤ 150 % of the initial limit			
	DC leakage current	Within the initial limit			
Damp heat (Steady state)	+60 °C, 90 % to 95 % RH, 1000 h, No-applied voltage				
	Capacitance change	Within ±20 % of the initial value			
	tanδ	≤ 150 % of the initial limit			
	DC leakage current	Within the initial limit (after voltage processing)			

Marking and Dimensions

※ Depends on the case size.

Size code	φD ±0.5	L ^{+0.1} / _{-0.4}	W ±0.2	H ±0.2	C ±0.2	R	P ※1
A5	4.0	5.4	4.3	4.3	5.0	0.6 to 0.8	1.0
B6	5.0	5.9	5.3	5.3	6.0	0.6 to 0.8	1.4
C6	6.3	5.9	6.6	6.6	7.3	0.6 to 0.8	2.1
E7	8.0	6.9	8.3	8.3	9.0	0.6 to 0.8	3.2
F8	10.0	7.9	10.3	10.3	11.0	0.6 to 0.8	4.6

※1 Reference

Characteristics list

Series	Rated voltage (V)	Rated capacitance (μF)	Case size (mm)		Size code	Specifications				Standard (Reel size: φ 380)	
			φD	L		Ripple current ※1 (mA rms)	ESR ※2 (mΩ max.)	tan δ ※3	LC ※4 (μA)	Part number	Min. Packaging Qty (pcs)
SVPS	4	33	4.0	5.4	A5	740	200	0.15	66	4SVPS33M	2000
		68	5.0	5.9	B6	1970	30	0.12	300	4SVPS68M	1500
		150	6.3	5.9	C6	2570	22	0.12	300	4SVPS150M	1000
		270	8.0	6.9	E7	3220	22	0.12	500	4SVPS270M	1000
		680	10.0	7.9	F8	4130	20	0.12	544	4SVPS680M	500
	6.3	22	4.0	5.4	A5	740	200	0.12	69.3	6SVPS22M	2000
		47	5.0	5.9	B6	1970	30	0.12	300	6SVPS47M	1500
		120	6.3	5.9	C6	2570	22	0.12	300	6SVPS120M	1000
		220	8.0	6.9	E7	3220	22	0.12	500	6SVPS220M	1000
		470	10.0	7.9	F8	4130	20	0.12	592	6SVPS470M	500
	10	10	4.0	5.4	A5	700	220	0.10	50	10SVPS10M	2000
		15	4.0	5.4		740	200	0.10	75	10SVPS15M	2000
		33	5.0	5.9	B6	1100	70	0.12	165	10SVPS33M	1500
		68	6.3	5.9	C6	2200	30	0.12	300	10SVPS68M	1000
		150	8.0	6.9	E7	2760	30	0.12	500	10SVPS150MX	1000
			10.0	7.9	F8	3020	30	0.12	300	10SVPS150M	500
		330	10.0	7.9		3770	24	0.12	660	10SVPS330M	500
	16	22	5.0	5.9	B6	1060	90	0.10	176	16SVPS22M	1500
		39	6.3	5.9	C6	2460	24	0.12	300	16SVPS39M	1000
		82	8.0	6.9	E7	2760	30	0.12	262	16SVPS82M	1000
		100	10.0	7.9	F8	2670	35	0.12	320	16SVPS100M	500
		180	10.0	7.9		3430	29	0.12	576	16SVPS180M	500
	20	22	6.3	5.9	C6	1450	60	0.10	88	20SVPS22M	1000
		47	8.0	6.9	E7	1890	45	0.12	188	20SVPS47M	1000
25	10	8.0	6.9	1500		60	0.10	125	25SVPS10M	1000	

※1: Ripple current (100 kHz/ +105 °C)

: The surface temperature of aluminum case top must not exceed 105 °C. A rise in temperature due to self-heating by ripple current should be factored in.

※2: ESR (100 kHz to 300 kHz/+20 °C)

※3: tan δ (120 Hz/+20 °C)

※4: After 2 minutes

◆Please refer to each page in this catalog for "Reflow conditions" and "Taping specifications"

Frequency correction factor for ripple current

Frequency	120 Hz ≤ f < 1 kHz	1 kHz ≤ f < 10 kHz	10 kHz ≤ f < 100 kHz	100 kHz ≤ f ≤ 500 kHz
Coefficient	0.05	0.3	0.7	1

SP-Cap

Guidelines and Precautions
Mounting specifications
Packing specifications

Selection guide

Surface mount type

Catalog EOL models

POSCAP

Guidelines and Precautions
Mounting specifications
Packing specifications

Selection guide

Surface mount type

Catalog Deletion models

Catalog EOL models

OS-CON

Guidelines and Precautions
Mounting specifications
Packing specifications

Selection guide
Line-up
Series system diagram
Size chart

Products list

SVT
SVPT
SVF
SVPK
SXV
SVPG
SVPA
SVPC
SVPB
SVPD
SVPS
SVPE
SVQP
SVP
SEK
SEF
SEPG
SXE
SEPF
SEPC
SEQP
SEP

Catalog EOL models

Hybrid

Guidelines and Precautions
Mounting specifications
Packing specifications

Selection guide

Surface mount type

Radial lead type



Low ESR(8 mΩ max.)

Large capacitance(1200 μF max.)

RoHS compliance, Halogen free

SP-Cap

Guidelines and Precautions
Mounting specifications
Packing specifications

Selection guide

Surface mount type

Catalog EOL models

POSCAP

Guidelines and Precautions
Mounting specifications
Packing specifications

Selection guide

Surface mount type

Catalog Deletion models

Catalog EOL models

OS-CON

Guidelines and Precautions
Mounting specifications
Packing specifications

Line-up
Series system diagram
Size chart
Selection guide

Products list

- SVT
- SVPT
- SVF
- SVPK
- SXV
- SVPG
- SVPF
- SVPA
- SVPC
- SVPB
- SVPD
- SVPS
- SVPE**
- SVQP
- SVP
- SEK
- SEF
- SEPG
- SXE
- SEPF
- SEPC
- SEQP
- SEP

Surface mount type

Radial lead type

Catalog EOL models

Hybrid

Guidelines and Precautions
Mounting specifications
Packing specifications

Selection guide

Surface mount type

Radial lead type

Specifications

Items	Specifications			
	Size code	B6	C6	C10
Category temperature range	-55 °C to +105 °C			
Rated voltage range	2.5 V to 6.3 V	2.5 V to 10 V	2 V to 16 V	16 V
Rated capacitance range	150 μF to 390 μF	220 μF to 390 μF	180 μF to 1200 μF	470 μF
Capacitance tolerance	±20 %(120 Hz/+20 °C)			
Leakage current	Please see the attached characteristics list			
Dissipation factor(tanδ)	Please see the attached characteristics list			
Endurance	+105 °C, 2000 h, rated voltage applied			
	Capacitance change	Within±20 % of the initial value		
	tanδ	≤ 150 % of the initial limit		
	DC leakage current	Within the initial limit		
Damp heat(Steady state)	+60 °C, 90 % to 95 % RH, 1000 h, No-applied voltage			
	Capacitance change	Within±20 % of the initial value		
	tanδ	≤ 150 % of the initial limit		
	DC leakage current	Within the initial limit (after voltage processing)		

Marking and Dimensions

Lot No.
Series code※
R. capacitance (μF)
R. voltage (V)

(unit : mm)

Size code	φD ±0.5	L ^{+0.1} / _{-0.4}	W ±0.2	H ±0.2	C ±0.2	R	P ※1
B6	5.0	5.9	5.3	5.3	6.0	0.6 to 0.8	1.4
C6	6.3	5.9	6.6	6.6	7.3	0.6 to 0.8	2.1
C10	6.3	9.9	6.6	6.6	7.3	0.6 to 0.8	2.1
F12	10.0	12.6	10.3	10.3	11.0	0.8 to 1.1	4.6

※1 Reference

※ Depends on the case size.

Characteristics list

Series	Rated voltage (V)	Rated capacitance (μF)	Case size (mm)		Size code	Specifications				Standard (Reel size: φ 380)			
			φD	L		Ripple current ※1 (mA rms)	ESR		tan δ ※2	LC ※3 (μA)	Part number	Min. Packaging Qty (pcs)	
						100 kHz/20 °C (mΩ max.)		300 kHz/20 °C (mΩ max.)					
SVPE	2	1200	6.3	9.9	C10	5230	8	8	0.12	500	2SVPE1200M	500	
													2.5
	330	5.0	5.9	3150	15	13	0.12	500	2R5SVPE330M	1500			
											390	5.0	
	6.3	150	5.0	5.9	B6	3900	10	9	0.12	500			
											180	5.0	
		220	5.0	5.9	3150	15	13	0.12	500	6SVPE180M			
											6.3	5.0	5.9
		10	220	6.3	5.9	C6	3900	10	9	0.12			
											16	180	6.3
	470	10.0	12.6	F12	4460	11	10	0.12	576	16SVPE180M			
											6100	10	9

※1: Rated ripple current (100 kHz/ +105 °C) ※2: tanδ (120 Hz/+20 °C) ※3: After 2 minutes

◆Please refer to each page in this catalog for "Reflow conditions" and "Taping specifications"

Frequency correction factor for ripple current

Frequency	120 Hz ≤ f < 1 kHz	1 kHz ≤ f < 10 kHz	10 kHz ≤ f < 100 kHz	100 kHz ≤ f ≤ 500 kHz
Coefficient	0.05	0.3	0.7	1



Guaranteed at 125 °C 1000 h

RoHS compliance, Halogen free

Specifications

Items	Specifications	
Size code	C6	E7
Category temperature range	-55 °C to +125 °C	
Rated voltage range	4 V to 20 V	6.3 V to 20 V
Rated capacitance range	22 μF to 150 μF	47 μF to 220 μF
Capacitance tolerance	±20 % (120 Hz/+20 °C)	
Leakage current	Please see the attached characteristics list	
Dissipation factor(tanδ)	Please see the attached characteristics list	
Endurance	+125 °C, 1000 h, rated voltage applied	
	Capacitance change	Within ±20 % of the initial value
	tanδ	≤ 200 % of the initial limit
	DC leakage current	Within the initial limit
Damp heat (Steady state)	+60 °C, 90 % to 95 % RH, 1000 h, No-applied voltage	
	Capacitance change	Within ±20 % of the initial value
	tanδ	≤ 150 % of the initial limit
	DC leakage current	Within the initial limit (after voltage processing)

Marking and Dimensions

※ Depends on the case size.

Size code	φD ±0.5	L ^{+0.1} / _{-0.4}	W ±0.2	H ±0.2	C ±0.2	R	P ※1
C6	6.3	5.9	6.6	6.6	7.3	0.6 to 0.8	2.1
E7	8.0	6.9	8.3	8.3	9.0	0.6 to 0.8	3.2

※1 Reference

Characteristics list

Series	Rated voltage (V)	Rated capacitance (μF)	Case size (mm)		Size code	Specifications					Standard (Reel size: φ 380)		
			φD	L		Ripple current ※1 (mA rms)	Allowable ripple current ※1 (mA rms)	ESR ※2 (mΩ max.)	tan δ ※3	LC ※4 (μA)	Part number	Min. Packaging Qty (pcs)	
SVQP	4	150	6.3	5.9	C6	572	1810	40	0.12	300	4SVQP150M	1000	
						538	1700	45	0.12	258	6SVQP82M	1000	
	6.3	100	6.3	5.9		E7	572	1810	40	0.12	315	6SVQP100M	1000
							810	2560	35	0.12	693	6SVQP220M	1000
	10	56	6.3	5.9	C6	538	1700	45	0.12	280	10SVQP56M	1000	
						E7	810	2560	35	0.12	600	10SVQP120M	1000
	16	120	8.0	6.9	E7		810	2560	35	0.12	750	10SVQP150M	1000
						16	39	6.3	5.9	C6	512	1620	50
	20	82	8.0	6.9	E7						670	2120	40
						20	22	6.3	5.9	C6	459	1450	60
	E7	47	8.3	6.9	598						1890	45	0.12

※1: Ripple current (100 kHz / +105 °C < Tx ≤ 125 °C), Allowable ripple current (100 kHz / Tx ≤ 105 °C)

※2: ESR (100 kHz to 300 kHz/+20 °C)

※3: tan δ (120 Hz/+20 °C)

※4: After 2 minutes

◆ Please refer to each page in this catalog for "Reflow conditions" and "Taping specifications".

Frequency correction factor for ripple current

Frequency	120 Hz ≤ f < 1 kHz	1 kHz ≤ f < 10 kHz	10 kHz ≤ f < 100 kHz	100 kHz ≤ f ≤ 500 kHz
Coefficient	0.05	0.3	0.7	1

SP-Cap

Guidelines and Precautions
Mounting specifications
Packaging specifications

Selection guide

Surface mount type

Catalog EOL models

POSCAP

Guidelines and Precautions
Mounting specifications
Packaging specifications

Selection guide

Surface mount type

Catalog Deletion models

Catalog EOL models

OSCON

Guidelines and Precautions
Mounting specifications
Packaging specifications

Selection guide
Line-up
Series system diagram
Size chart

Products list

SVT
SVPT
SVF
SVPK
SXV
SVPG
SVPF
SVPA
SVPB
SVPD
SVPS
SVPE
SVQP
SVP

Surface mount type

Radial lead type

Catalog EOL models

Hybrid

Guidelines and Precautions
Mounting specifications
Packaging specifications

Selection guide

Surface mount type

Radial lead type



Standard

Wealth models

RoHS compliance, Halogen free

SP-Cap

Guidelines and Precautions
Mounting specifications
Packing specifications

Selection guide

Surface mount type

Catalog EOL models

POSCAP

Guidelines and Precautions
Mounting specifications
Packing specifications

Selection guide

Surface mount type

Catalog Deletion models

Catalog EOL models

OS-CON

Guidelines and Precautions
Mounting specifications
Packing specifications

Line-up
Series system diagram
Size chart
Selection guide

Products list

- SVT
- SVPT
- SVF
- SVPK
- SXV
- SVPG
- SVPF
- SVPA
- SVPC
- SVPB
- SVPD
- SVPS
- SVPE
- SVQP
- SVP**
- SEK
- SEF
- SEPG
- SXE
- SEPF
- SEPC
- SEQP
- SEP

Surface mount type

Radial lead type

Catalog EOL models

Hybrid

Guidelines and Precautions
Mounting specifications
Packing specifications

Selection guide

Surface mount type

Radial lead type

Specifications

Items	Specifications						
	A5	B6	C6	E7	E12	F8	F12
Size code	A5	B6	C6	E7	E12	F8	F12
Category temperature range	-55 °C to +105 °C						
Rated voltage range(V)	4 to 16	4 to 20	2.5 to 20	4 to 20	2.5 to 20	4 to 20	2.5 to 20
Rated capacitance range(μF)	3.3 to 33	10 to 68	22 to 220	33 to 330	100 to 680	56 to 680	150 to 1500
Capacitance tolerance	±20 % (120 Hz/+20 °C)						
Leakage current	Please see the attached characteristics list						
Dissipation factor(tanδ)	Please see the attached characteristics list						
Endurance	+105 °C, 2000 h, rated voltage applied						
	Capacitance change	Within ±20 % of the initial value					
	tanδ	≤ 150 % of the initial limit					
	DC leakage current	Within the initial limit					
Damp heat(Steady state)	+60 °C, 90 % to 95 % RH, 1000 h, No-applied voltage						
	Capacitance change	Within ±20 % of the initial value					
	tanδ	≤ 150 % of the initial limit					
	DC leakage current	Within the initial limit (after voltage processing)					

Marking and Dimensions

(unit : mm)

Size code	φD ±0.5	L ^{+0.1} / _{-0.4}	W ±0.2	H ±0.2	C ±0.2	R	P ※1
A5	4.0	5.4	4.3	4.3	5.0	0.6 to 0.8	1.0
B6	5.0	5.9	5.3	5.3	6.0	0.6 to 0.8	1.4
C6	6.3	5.9	6.6	6.6	7.3	0.6 to 0.8	2.1
E7	8.0	6.9	8.3	8.3	9.0	0.6 to 0.8	3.2
E12	8.0	11.9	8.3	8.3	9.0	0.8 to 1.1	3.2
F8	10.0	7.9	10.3	10.3	11.0	0.6 to 0.8	4.6
F12	10.0	12.6	10.3	10.3	11.0	0.8 to 1.1	4.6

※1 Reference

Characteristics list

Series	Rated voltage (V)	Rated capacitance (μF)	Case size (mm)		Size code	Specifications				Standard(Reel size: φ 380)		
			φD	L		Ripple current ※1 (mA rms)	ESR ※2 (mΩ max.)	tan δ ※3	LC ※4 (μA)	Part number	Min. Packaging Qty (pcs)	
SVP	2.5	220	6.3	5.9	C6	2390	23	0.12	110	2R5SVP220M	1000	
		680	8.0	11.9	E12	4520	13	0.15	340	2R5SVP680M	400	
		1500	10.0	12.6	F12	5440	12	0.18	750	2R5SVP1500M	400	
	4	33	4.0	5.4	A5	740	200	0.15	66	4SVP33M	2000	
		39	5.0	5.9	B6	1100	70	0.12	78	4SVP39M	1500	
		68	5.0	5.9		1400	60	0.12	136	4SVP68M	1500	
		150	6.3	5.9	C6	1810	40	0.12	120	4SVP150MX	1000	
		330	8.0	6.9	E7	2560	35	0.12	264	4SVP330M	1000	
		560	8.0	11.9	E12	4520	13	0.15	448	4SVP560M	400	
		680	10.0	7.9	F8	3700	25	0.12	544	4SVP680M	500	
		1200	10.0	12.6	F12	5440	12	0.18	960	4SVP1200M	400	
		6.3	22	4.0	5.4	A5	740	200	0.12	69.3	6SVP22M	2000
	47		5.0	5.9	B6	1100	70	0.12	148	6SVP47M	1500	
	82		6.3	5.9	C6	1700	45	0.12	103	6SVP82M	1000	
	100		6.3	5.9		1810	40	0.12	126	6SVP100M	1000	
	120		6.3	5.9		2780	17	0.12	151	6SVP120MV	1000	
	220		8.0	6.9	E7	2560	35	0.12	277	6SVP220MX	1000	
			10.0	7.9	F8	3700	25	0.12	277	6SVP220M	500	
	330		10.0	7.9		3700	25	0.12	416	6SVP330M	500	
	470		10.0	7.9	E12	3700	25	0.12	592	6SVP470MX	500	
			8.0	11.9		4210	15	0.15	592	6SVP470M	400	
	820		10.0	12.6	F12	5440	12	0.15	775	6SVP820M	400	
	10		4.7	4.0	5.4	A5	670	240	0.08	23.5	10SVP4R7M	2000
			6.8	4.0	5.4		670	240	0.09	34	10SVP6R8M	2000
			10	4.0	5.4		700	220	0.10	50	10SVP10M	2000
			15	4.0	5.4		740	200	0.10	75	10SVP15M	2000
		33	5.0	5.9	B6	1100	70	0.12	165	10SVP33M	1500	
		47	6.3	5.9	C6	1620	50	0.12	94	10SVP47M	1000	
		56	6.3	5.9		1700	45	0.12	112	10SVP56M	1000	
		120	8.0	6.9	E7	2560	35	0.12	240	10SVP120M	1000	
		150	8.0	6.9	F8	2560	35	0.12	300	10SVP150MX	1000	
			10.0	7.9		3020	30	0.12	300	10SVP150M	500	
		270	10.0	7.9	3700	25	0.12	540	10SVP270M	500		
		330	10.0	7.9	E12	3700	25	0.12	660	10SVP330MX	500	
			8.0	11.9		3950	17	0.15	660	10SVP330M	400	
		560	10.0	12.6	F12	5230	13	0.15	840	10SVP560M	400	
		16	3.3	4.0	5.4	A5	660	260	0.07	26.4	16SVP3R3M	2000
			15	5.0	5.9	B6	1020	120	0.10	120	16SVP15M	1500
			22	5.0	5.9		1060	90	0.10	176	16SVP22M	1500
			39	6.3	5.9	C6	1620	50	0.10	125	16SVP39M	1000
	56		8.0	6.9	E7	1890	45	0.12	179	16SVP56M	1000	
	82		8.0	6.9		2120	40	0.12	262	16SVP82M	1000	
	100		10.0	7.9	F8	2670	35	0.12	320	16SVP100M	500	
	150		10.0	7.9		3020	30	0.12	480	16SVP150M	500	
	180		10.0	7.9		3020	30	0.12	576	16SVP180MX	500	
			8.0	11.9	E12	3640	20	0.15	576	16SVP180M	400	
	330		10.0	12.6	F12	4720	16	0.15	792	16SVP330M	400	
	20		10	5.0	5.9	B6	1020	120	0.10	100	20SVP10M	1500
			22	6.3	5.9	C6	1450	60	0.10	88	20SVP22M	1000
			27	6.3	5.9		1450	60	0.10	108	20SVP27M	1000
			33	8.0	6.9	E7	1890	45	0.12	132	20SVP33M	1000
		47	8.0	6.9	F8	1890	45	0.12	188	20SVP47M	1000	
		56	10.0	7.9		2400	40	0.12	224	20SVP56M	500	
		68	10.0	7.9	2400	40	0.12	272	20SVP68M	500		
100		8.0	11.9	E12	3320	24	0.15	400	20SVP100M	400		
150		10.0	12.6	F12	4320	20	0.15	600	20SVP150M	400		

※1:Ripple current(100 kHz/+105 °C) ※2:ESR (100 kHz to 300 kHz/+20 °C) ※3:tan δ (120 Hz/+20 °C) ※4:After 2 minutes

◆Please refer to each page in this catalog for "Reflow conditions" and "Taping specifications".

Frequency correction factor for ripple current

Frequency	120 Hz ≤ f < 1 kHz	1 kHz ≤ f < 10 kHz	10 kHz ≤ f < 100 kHz	100 kHz ≤ f ≤ 500 kHz
Coefficient	0.05	0.3	0.7	1

Design and specifications are each subject to change without notice. Ask factory for the current technical specifications before purchase and/or use.
Should a safety concern arise regarding this product, please be sure to contact us immediately.

SP-Cap

Guidelines and Precautions
Mounting specifications
Packing specifications

Selection guide

Surface mount type

Catalog EOL models

POSCAP

Guidelines and Precautions
Mounting specifications
Packing specifications

Selection guide

Surface mount type

Catalog Deletion models

Catalog EOL models

OS-CON

Guidelines and Precautions
Mounting specifications
Packing specifications

Selection guide
Line-up
Series system diagram
Size chart

Products list

SVT
SVPT
SVF
SVPK
SXV
SVPG
SVPF
SVPA
SVPB
SVPD
SVPS
SVPE
SVQP
SVP

SEK
SEF
SEPG
SXE
SEPF
SEPC
SEQP
SEP

Catalog EOL models

Hybrid

Guidelines and Precautions
Mounting specifications
Packing specifications

Selection guide

Surface mount type

Radial lead type



High voltage(50 V max.)

Guaranteed at 125 °C 1000 h

RoHS compliance, Halogen free

SP-Cap

Guidelines and Precautions
Mounting specifications
Packing specifications

Selection guide

Surface mount type

Catalog EOL models

POSCAP

Guidelines and Precautions
Mounting specifications
Packing specifications

Selection guide

Surface mount type

Catalog Deletion models
Catalog EOL models

OS-CON

Guidelines and Precautions
Mounting specifications
Packing specifications

Line-up
Series system diagram
Size chart
Selection guide

Products list

- SVT
- SVPT
- SVF
- SVPK
- SXV
- SVPG
- SVPF
- SVPA
- SVPC
- SVPB
- SVPD
- SVPS
- SVPE
- SVQP
- SVP
- SEK**
- SEF
- SEPG
- SXE
- SEPF
- SEPC
- SEQP
- SEP

Surface mount type

Radial lead type

Catalog EOL models

Hybrid

Guidelines and Precautions
Mounting specifications
Packing specifications

Selection guide

Surface mount type

Radial lead type

Specifications

Items	Specifications			
	C6	E7	E12	F13
Size code	C6	E7	E12	F13
Category temperature range	-55 °C to +125 °C			
Rated voltage range	25 V to 50 V			
Rated capacitance range	22 μF to 82 μF	33 μF to 120 μF	68 μF to 270 μF	120 μF to 470 μF
Capacitance tolerance	±20 % (120 Hz/+20 °C)			
Leakage current	Please see the attached characteristics list			
Dissipation factor(tanδ)	Please see the attached characteristics list			
Endurance	+125 °C, 1000 h, rated voltage applied			
	Capacitance change	Within ±20 % of the initial value		
	tanδ	≤ 200 % of the initial limit		
	DC leakage current	Within the initial limit		
Damp heat(Steady state)	+60 °C, 90 % to 95 % RH, 1000 h, No-applied voltage			
	Capacitance change	Within ±20 % of the initial value		
	tanδ	≤ 150 % of the initial limit		
	DC leakage current	Within the initial limit (after voltage processing)		

Marking and Dimensions

(unit : mm)

Size code	φD ±0.5	L max	F ±0.5	φd ±0.05
C6	6.3	6.0	2.5	0.5
E7	8.0	7.0	3.5	0.5
E12	8.0	12.0	3.5	0.6
F13	10.0	13.0	5.0	0.6

※ Depends on the case size.

Characteristics list

Series	Rated voltage (V)	Rated capacitance (μF)	Case size (mm)		Size code	Specifications					Part number
			φD	L		Ripple current ※1 (mA rms)	Allowable ripple current※1 (mA rms)	ESR ※2 (mΩ max.)	tan δ ※3	LC ※4 (μA)	
SEK	25	82	6.3	6.0	C6	960	3060	25	0.12	410	25SEK82M
		120	8.0	7.0	E7	1010	3200	24	0.12	600	25SEK120M
		270	8.0	12.0	E12	1470	4650	16	0.12	1350	25SEK270M
		470	10.0	13.0	F13	1590	5000	14	0.12	2350	25SEK470M
	35	47	6.3	6.0	C6	930	2950	27	0.12	329	35SEK47M
		82	8.0	7.0	E7	960	3060	25	0.12	574	35SEK82M
		180	8.0	12.0	E12	1260	4000	20	0.12	1260	35SEK180M
		330	10.0	13.0	F13	1390	4400	18	0.12	2310	35SEK330M
	50	22	6.3	6.0	C6	820	2600	35	0.12	220	50SEK22M
		33	8.0	7.0	E7	850	2700	35	0.12	330	50SEK33M
		68	8.0	12.0	E12	1200	3800	25	0.12	680	50SEK68M
		120	10.0	13.0	F13	1350	4300	20	0.12	1200	50SEK120M

※1: Ripple current (100 kHz/ +105 °C < Tx ≤ +125 °C) /Allowable ripple current (100 kHz/ Tx ≤ +105 °C)

※2: ESR (100 kHz to 300 kHz/+20 °C)

※3: tan δ (120 Hz/+20 °C)

※4: After 2 minutes

◆Please refer to each page in this catalog for "Flow conditions" and "Taping specifications".

Frequency correction factor for ripple current

Frequency	120 Hz ≤ f < 1 kHz	1 kHz ≤ f < 10 kHz	10 kHz ≤ f < 100 kHz	100 kHz ≤ f ≤ 500 kHz
Coefficient	0.05	0.3	0.7	1



High voltage (35 V max.)

Large capacitance (1000 μ F max.)

RoHS compliance, Halogen free

Specifications

Items	Specifications			
	C6	E7	E12	F13
Size code	C6	E7	E12	F13
Category temperature range	-55 °C to +125 °C			
Rated voltage range	16 V to 35 V			
Rated capacitance range	22 μ F to 180 μ F	39 μ F to 270 μ F	82 μ F to 560 μ F	120 μ F to 1000 μ F
Capacitance tolerance	\pm 20 % (120 Hz/+20 °C)			
Leakage current	Please see the attached characteristics list			
Dissipation factor (tan δ)	Please see the attached characteristics list			
Endurance	+125 °C, 1000 h, rated voltage applied			
	Capacitance change	Within \pm 20 % of the initial value		
	tan δ	\leq 200 % of the initial limit		
	DC leakage current	Within the initial limit		
Damp heat (Steady state)	+60 °C, 90 % to 95 % RH, 1000 h, No-applied voltage			
	Capacitance change	Within \pm 20 % of the initial value		
	tan δ	\leq 150 % of the initial limit		
	DC leakage current	Within the initial limit (after voltage processing)		

Marking and Dimensions

※ Depends on the case size.

Size code	ϕ D \pm 0.5	L max	F \pm 0.5	ϕ d \pm 0.05
C6	6.3	6.0	2.5	0.5
E7	8.0	7.0	3.5	0.5 [※]
E12	8.0	12.0	3.5	0.6
F13	10.0	13.0	5.0	0.6

(unit : mm)

※ 32SEF68M: 0.6 \pm 0.05

Characteristics list

Series	Rated voltage (V)	Rated capacitance (μ F)	Case size (mm)		Size code	Specifications					Part number
			ϕ D	L		Ripple current \times 1 (mA rms)	Allowable ripple current \times 1 (mA rms)	ESR \times 2 (m Ω max.)	tan δ \times 3	LC \times 4 (μ A)	
SEF	16	180	6.3	6.0	C6	1040	3300	22	0.12	576	16SEF180M
		270	8.0	7.0	E7	1040	3300	22	0.12	864	16SEF270M
		560	8.0	12.0	E12	1560	4950	14	0.12	1792	16SEF560M
		1000	10.0	13.0	F13	1700	5400	12	0.12	3200	16SEF1000M
	20	120	6.3	6.0	C6	1010	3200	25	0.12	480	20SEF120M
		180	8.0	7.0	E7	1010	3200	25	0.12	720	20SEF180M
		390	8.0	12.0	E12	1560	4950	14	0.12	1560	20SEF390M
		560	10.0	13.0	F13	1700	5400	12	0.12	2240	20SEF560M
	25	56	6.3	6.0	C6	880	2800	30	0.12	280	25SEF56M
		82	8.0	7.0	E7	940	3000	28	0.12	410	25SEF82M
		180	8.0	12.0	E12	1470	4650	16	0.12	900	25SEF180M
		330	10.0	13.0	F13	1580	5000	14	0.12	1650	25SEF330M
	32	68	8.0	7.0	E7	1010	3200	25	0.10	435	32SEF68M
	35	22	6.3	6.0	C6	820	2600	35	0.12	154	35SEF22M
		39	8.0	7.0	E7	880	2800	30	0.12	273	35SEF39M
		82	8.0	12.0	E12	1260	4000	20	0.12	574	35SEF82M
120		10.0	13.0	F13	1390	4400	18	0.12	840	35SEF120M	

※1: Ripple current (100 kHz / +105 °C < T_x \leq +125 °C) / Allowable ripple current (100 kHz / T_x \leq +105 °C)

※2: ESR (100 kHz to 300 kHz/+20 °C)

※3: tan δ (120 Hz/+20 °C)

※4: After 2 minutes

◆ Please refer to each page in this catalog for "Flow conditions" and "Taping specifications"

Frequency correction factor for ripple current

Frequency	120 Hz \leq f < 1 kHz	1 kHz \leq f < 10 kHz	10 kHz \leq f < 100 kHz	100 kHz \leq f \leq 500 kHz
Coefficient	0.05	0.3	0.7	1

SP-Cap

Guidelines and Precautions
Mounting specifications
Packing specifications

Selection guide

Surface mount type

Catalog EOL models

POSCAP

Guidelines and Precautions
Mounting specifications
Packing specifications

Selection guide

Surface mount type

Catalog Deletion models

Catalog EOL models

OSCON

Guidelines and Precautions
Mounting specifications
Packing specifications

Selection guide

Line-up

Series system diagram

Size chart

Products list

- SVT
- SVPT
- SVF
- SVPK
- SXV
- SVPG
- SVPA
- SVPC
- SVPB
- SVPD
- SVPS
- SVPE
- SVQP
- SVP
- SEK
- SEF**
- SEPG
- SXE
- SEPF
- SEPC
- SEQP
- SEP

Catalog EOL models

Hybrid

Guidelines and Precautions
Mounting specifications
Packing specifications

Selection guide

Surface mount type

Radial lead type



High ripple current (6100 mA rms max.)

RoHS compliance, Halogen free

Specifications

Items	Specifications				
Size code	B9	C9	C10	E9	E13
Category temperature range	-55 °C to +105 °C				
Rated voltage range	16 V				
Rated capacitance range	150 μF	270 μF		470 μF	560 μF
Capacitance tolerance	±20 % (120 Hz/+20 °C)				
Leakage current	Please see the attached characteristics list				
Dissipation factor(tanδ)	Please see the attached characteristics list				
Endurance	+105 °C, 5000 h, rated voltage applied				
	Capacitance change	Within ±20 % of the initial value			
	tanδ	≤ 150 % of the initial limit			
	DC leakage current	Within the initial limit			
Damp heat(Steady state)	+60 °C, 90 % to 95 % RH, 1000 h, No-applied voltage				
	Capacitance change	Within ±20 % of the initial value			
	tanδ	≤ 150 % of the initial limit			
	DC leakage current	Within the initial limit (after voltage processing)			

Marking and Dimensions

Polarity marking (-)

Lot. No.

Series code**

R. capacitance (μF)

R. voltage(V)

** Depends on the case size.

<E13 size>

<B9, C9, C10, E9 size>

Flat rubber is used for B9, C9, C10, and E9 size.

(unit : mm)

Size code	φD ±0.5	L max	F ±0.5	φd ±0.05
B9	5.0	9.0	2.0	0.6
C9	6.3	9.0	2.5	0.6
C10	6.3	10.0	2.5	0.5
E9	8.0	9.0	3.5	0.6
E13	8.0	13.0	3.5	0.6

Characteristics list

Series	Rated voltage (V)	Rated capacitance (μF)	Case size (mm)		Size code	Specifications				Part number
			φD	L		Ripple current ※1 (mA rms)	ESR ※2 (mΩ max.)	tan δ ※3	LC ※4 (μA)	
SEPG	16	150	5.0	9.0	B9	4500	12	0.12	480	16SEPG150M
		270	6.3	9.0	C9	5040	10	0.12	864	16SEPG270W
			6.3	10.0	C10	5800	8	0.12	864	16SEPG270M
		470	8.0	9.0	E9	5400	8	0.12	1504	16SEPG470M
		560	8.0	13.0	E13	6100	8	0.12	1792	16SEPG560M

※1: Ripple current (100 kHz/ +105 °C)

※2: ESR (100 kHz/+20 °C)

※3: tan δ (120 Hz/+20 °C)

※4: After 2 minutes

◆Please refer to each page in this catalog for "Flow conditions" and "Taping specifications"

Frequency correction factor for ripple current

Frequency	120 Hz ≤ f < 1 kHz	1 kHz ≤ f < 10 kHz	10 kHz ≤ f < 100 kHz	100 kHz ≤ f ≤ 500 kHz
Coefficient	0.05	0.3	0.7	1

Design and specifications are each subject to change without notice. Ask factory for the current technical specifications before purchase and/or use. Should a safety concern arise regarding this product, please be sure to contact us immediately.



Super high voltage(100 V max.)

Guaranteed at 125 °C 1000 h

RoHS compliance, Halogen free

Specifications

Items	Specifications			
	E7	E12	F8	F13
Size code	E7	E12	F8	F13
Category temperature range	-55 °C to +125 °C			
Rated voltage range	63 V to 100 V			
Rated capacitance range	6.8 μF to 18 μF	15 μF to 56 μF	15 μF to 39 μF	18 μF to 100 μF
Capacitance tolerance	±20 % (120 Hz/+20 °C)			
Leakage current	Please see the attached characteristics list			
Dissipation factor(tanδ)	Please see the attached characteristics list			
Endurance	+125 °C, 1000 h, rated voltage applied			
	Capacitance change	Within ±20 % of the initial value		
	tanδ	≤ 200 % of the initial limit		
	DC leakage current	Within the initial limit		
Damp heat(Steady state)	+60 °C, 90 % to 95 % RH, 1000 h, No-applied voltage			
	Capacitance change	Within ±20 % of the initial value		
	tanδ	≤ 150 % of the initial limit		
	DC leakage current	Within the initial limit (after voltage processing)		

Marking and Dimensions

Polarity marking(-)
 Lot. No.
 Series code※
 R. capacitance(μF)
 R. voltage(V)

Dimensions: φD, L max., 15min., 4min., 19min., φd, L

※ Depends on the case size.

Size code	φD ±0.5	L max	F ±0.5	φd ±0.05
E7	8.0	7.0	3.5	0.45
E12	8.0	12.0	3.5	0.6
F8	10.0	8.0	5.0	0.5
F13	10.0	13.0	5.0	0.6

(unit : mm)

Characteristics list

Series	Rated voltage (V)	Rated capacitance (μF)	Case size(mm)		Size code	Specifications					Part number	
			φD	L		Ripple current ※1 (mA rms)	Allowable ripple current※1 (mA rms)	ESR ※2 (mΩ max.)	tan δ ※3	LC ※4 (μA)		
SXE	63	18	8.0	7.0	E7	340	1100	60	0.12	56	63SXE18M	
		33	8.0	12.0	E12	930	2950	25	0.12	104	63SXE33M	
		39	8.0	12.0		930	2950	25	0.12	122	63SXE39M	
		56	8.0	8.0	F8	690	2190	50	0.12	122	63SXE39MX	
		56	8.0	12.0	E12	930	2950	25	0.12	176	63SXE56M	
		68	10.0	13.0	F13	1030	3280	25	0.12	214	63SXE68M	
		100	10.0	13.0		1030	3280	25	0.12	315	63SXE100M	
		80	12	8.0	7.0	E7	340	1100	60	0.12	48	80SXE12M
			27	8.0	12.0	E12	780	2490	35	0.12	108	80SXE27M
				10.0	8.0	F8	660	2080	55	0.12	108	80SXE27MX
			33	8.0	12.0	E12	780	2490	35	0.12	132	80SXE33M
			47	10.0	13.0	F13	980	3100	28	0.12	188	80SXE47M
	56			10.0	13.0		980	3100	28	0.12	224	80SXE56M
	100	6.8	8.0	7.0	E7	340	1100	60	0.12	34	100SXE6R8M	
		15	10.0	8.0	F8	630	2000	60	0.12	75	100SXE15MX	
			8.0	12.0	E12	730	2350	40	0.12	75	100SXE15M	
		18	10.0	13.0	F13	940	3000	30	0.12	90	100SXE18M	
			8.0	12.0	E12	730	2350	40	0.12	90	100SXE18MX	
		22	10.0	13.0	F13	940	3000	30	0.12	110	100SXE22M	
		27	10.0	13.0		940	3000	30	0.12	135	100SXE27M	

※1: Ripple current (100 kHz/ +105 °C < Tx ≤ 125 °C), Allowable ripple current (100 kHz / Tx ≤ 105 °C)

※2: ESR (100 kHz to 300 kHz/+20 °C)

※3: tanδ (120 Hz/+20 °C)

※4: After 2 minutes

◆Please refer to the P73 to 76 in this catalog for "Flow conditions" and "Taping specifications".

Frequency correction factor for ripple current

Frequency	120 Hz ≤ f < 1 kHz	1 kHz ≤ f < 10 kHz	10 kHz ≤ f < 100 kHz	100 kHz ≤ f ≤ 500 kHz
Coefficient	0.05	0.3	0.7	1

SP-Cap

Guidelines and Precautions
Mounting specifications
Packing specifications

Selection guide

Surface mount type

Catalog EOL models

POSCAP

Guidelines and Precautions
Mounting specifications
Packing specifications

Selection guide

Surface mount type

Catalog Deletion models

Catalog EOL models

OSCON

Guidelines and Precautions
Mounting specifications
Packing specifications

Selection guide
Line-up
Series system diagram
Size chart

Products list

- SVT
- SVPT
- SVF
- SVPK
- SXV
- SVPG
- SVPA
- SVPC
- SVPB
- SVPD
- SVPS
- SVPE
- SVQP
- SVP
- SEK
- SEF
- SEPG
- SXE**
- SEPF
- SEPC
- SEQP
- SEP

Catalog EOL models

Hybrid

Guidelines and Precautions
Mounting specifications
Packing specifications

Selection guide

Surface mount type

Radial lead type



High voltage (35 V max.)

Large capacitance (1000 μ F max.)

RoHS compliance, Halogen free

SP-Cap

Guidelines and Precautions
Mounting specifications
Packing specifications

Selection guide

Surface mount type

Catalog EOL models

POSCAP

Guidelines and Precautions
Mounting specifications
Packing specifications

Selection guide

Surface mount type

Catalog Deletion models

Catalog EOL models

OS-CON

Guidelines and Precautions
Mounting specifications
Packing specifications

Line-up

Series system diagram
Size chart

Products list

- SVT
- SVPT
- SVF
- SVPK
- SXV
- SVPG
- SVPF
- SVPA
- SVPC
- SVPB
- SVPD
- SVPS
- SVPE
- SVQP
- SVP
- SEK
- SEF
- SEPG
- SXE
- SEPF**
- SEPC
- SEQP
- SEP

Surface mount type

Radial lead type

Catalog EOL models

Hybrid

Guidelines and Precautions
Mounting specifications
Packing specifications

Selection guide

Surface mount type

Radial lead type

Specifications

Items	Specifications				
	Size code	C55	C6	E7	E12
Category temperature range	-55 °C to +105 °C				
Rated voltage range	16 V to 32 V		16 V to 35V		
Rated capacitance range	22 μ F to 150 μ F	22 μ F to 180 μ F	39 μ F to 270 μ F	82 μ F to 560 μ F	120 μ F to 1000 μ F
Capacitance tolerance	\pm 20 % (120 Hz/+20 °C)				
Leakage current	Please see the attached characteristics list				
Dissipation factor (tan δ)	Please see the attached characteristics list				
Endurance	+105 °C, 5000 h, rated voltage applied				
	Capacitance change	Within \pm 20 % of the initial value			
	tan δ	\leq 150 % of the initial limit			
	DC leakage current	Within the initial limit			
Damp heat (Steady state)	+60 °C, 90 % to 95 % RH, 1000 h, No-applied voltage				
	Capacitance change	Within \pm 20 % of the initial value			
	tan δ	\leq 150 % of the initial limit			
	DC leakage current	Within the initial limit (after voltage processing)			

Marking and Dimensions

Polarity marking (-)

Lot. No.

Series code*

R. capacitance (μ F)

R. voltage (V)

ϕD

ϕd

L max.

15min.

4min.

19min.

(+)

(-)

L

* Depends on the case size.

(unit : mm)

Size code	$\phi D \pm 0.5$	L max	F ± 0.5	$\phi d \pm 0.05$
C55	6.3	5.5	2.5	0.45
C6	6.3	6.0	2.5	0.5
E7	8.0	7.0	3.5	0.5 *
E12	8.0	12.0	3.5	0.6
F13	10.0	13.0	5.0	0.6

* 32SEPF68M: 0.6 \pm 0.05

Characteristics list

Series	Rated voltage (V)	Rated capacitance (μF)	Case size (mm)		Size code	Specifications				Part number
			φD	L		Ripple current ※1 (mA rms)	ESR ※2 (mΩ max.)	tan δ ※3	LC ※4 (μA)	
SEPF	16	150	6.3	5.5	C55	2590	30	0.12	480	16SEPF150M
		180	6.3	6.0	C6	3300	22	0.12	576	16SEPF180M
		270	8.0	7.0	E7	3300	22	0.12	864	16SEPF270M
		560	8.0	12.0	E12	4950	14	0.12	1792	16SEPF560M
		1000	10.0	13.0	F13	5400	12	0.12	3200	16SEPF1000M
	20	120	6.3	6.0	C6	3200	25	0.12	480	20SEPF120M
		180	8.0	7.0	E7	3200	25	0.12	720	20SEPF180M
		390	8.0	12.0	E12	4950	14	0.12	1560	20SEPF390M
		560	10.0	13.0	F13	5400	12	0.12	2240	20SEPF560M
	25	56	6.3	6.0	C6	2800	30	0.12	280	25SEPF56M
		82	8.0	7.0	E7	3000	28	0.12	410	25SEPF82M
		180	8.0	12.0	E12	4650	16	0.12	900	25SEPF180M
		330	10.0	13.0	F13	5000	14	0.12	1650	25SEPF330M
	32	22	6.3	5.5	C55	2400	35	0.12	140	32SEPF22M
		68	8.0	7.0	E7	3200	25	0.10	435	32SEPF68M
	35	22	6.3	6.0	C6	2600	35	0.12	154	35SEPF22M
		39	8.0	7.0	E7	2800	30	0.12	273	35SEPF39M
		82	8.0	12.0	E12	4000	20	0.12	574	35SEPF82M
		120	10.0	13.0	F13	4400	18	0.12	840	35SEPF120M

※1: Rated ripple current (100 kHz/ +105 °C)

※2: ESR (100 kHz to 300 kHz/+20 °C)

※3: tan δ (120 Hz/+20 °C)

※4: After 2 minutes

◆ Please refer to each page in this catalog for "Flow conditions" and "Taping specifications".

Frequency correction factor for ripple current

Frequency	120 Hz ≤ f < 1 kHz	1 kHz ≤ f < 10 kHz	10 kHz ≤ f < 100 kHz	100 kHz ≤ f ≤ 500 kHz
Coefficient	0.05	0.3	0.7	1

SP-Cap

Guidelines and Precautions
Mounting specifications
Packing specifications

Selection guide

Surface mount type

Catalog EOL models

POSCAP

Guidelines and Precautions
Mounting specifications
Packing specifications

Selection guide

Surface mount type

Catalog Deletion models

Catalog EOL models

OS-CON

Guidelines and Precautions
Mounting specifications
Packing specifications

Selection guide
Line-up
Series system diagram
Size chart

Products list

SVT
SVPT
SVF
SVPK
SXV
SVPG
SVPF
SVPA
SVPC
SVPB
SVPD
SVPS
SVPE
SVQP
SVP
SEK
SEF
SEPG
SXE
SEPF
SEPC
SEQP
SEP

Surface mount type

Radial lead type

Catalog EOL models

Hybrid

Guidelines and Precautions
Mounting specifications
Packing specifications

Selection guide

Surface mount type

Radial lead type



Super low ESR (5 mΩ max.)

Large capacitance (2700 μF max.)

RoHS compliance, Halogen free

SP-Cap

Guidelines and Precautions
Mounting specifications
Packing specifications

Selection guide

Surface mount type

Catalog EOL models

POSCAP

Guidelines and Precautions
Mounting specifications
Packing specifications

Selection guide

Surface mount type

Catalog Deletion models

Catalog EOL models

OS-CON

Guidelines and Precautions
Mounting specifications
Packing specifications

Line-up

Series system diagram
Size chart

Selection guide

Products list

- SVT
- SVPT
- SVF
- SVPK
- SXV
- SVPG
- SVPF
- SVPA
- SVPC
- SVPB
- SVPD
- SVPS
- SVPE
- SVQP
- SVP
- SEK
- SEF
- SEPG
- SXE
- SEPF
- SEPC**
- SEQP
- SEP

Surface mount type

Radial lead type

Catalog EOL models

Hybrid

Guidelines and Precautions
Mounting specifications
Packing specifications

Selection guide

Surface mount type

Radial lead type

Specifications

Items	Specifications									
	Size code	B9	C55	C6	C9	E7	E9	E12	E13	F13
Category temperature range	-55 °C to +105 °C									
Rated voltage range (V)	2.5	6.3	2.5 to 16	6.3 to 16	2.5 to 16	16	2.5 to 6.3	2.5 to 16		
Rated capacitance range (μF)	100 to 560	220	100 to 560	100 to 820	150 to 1000	180 to 1000	180 to 270	470 to 820	470 to 2700	
Capacitance tolerance	±20 % (120 Hz/+20 °C)									
Leakage current	Please see the attached characteristics list									
Dissipation factor (tan δ)	Please see the attached characteristics list									
Endurance	+105 °C, 5000 h, rated voltage applied									
	Capacitance change	Within ±20 % of the initial value								
	tan δ	≤ 150 % of the initial limit								
	DC leakage current	Within the initial limit								
Damp heat (Steady state)	+60 °C, 90 % to 95 % RH, 1000 h, No-applied voltage									
	Capacitance change	Within ±20 % of the initial value								
	tan δ	≤ 150 % of the initial limit								
	DC leakage current	Within the initial limit (after voltage processing)								

Marking and Dimensions

(E12, E13, F13 size)

Size code	φD ±0.5	L max	F ±0.5	φd ±0.05
B9	5.0	9.0	2.0	0.6
C55	6.3	5.5	2.5	0.45
C6	6.3	6.0	2.5	0.5※1
C9	6.3	9.0	2.5	0.6
E7	8.0	7.0	3.5	0.6※2
E9	8.0	9.0	3.5	0.6
E12	8.0	12.0	3.5	0.6
E13	8.0	13.0	3.5	0.6
F13	10.0	13.0	5.0	0.6

※1 16SEPC100M: 0.45±0.05
※2 16SEPC150MD, 10SEPC270M: 0.45±0.05

※ Depends on the case size.

(B9, C55, C6, C9, E7, E9 size)

Flat rubber is used for B9, C55, C6, C9, E7, and E9 size.

Characteristics list

Series	Rated voltage (V)	Rated capacitance (μF)	Case size (mm)		Size code	Specifications				Part number
			φD	L		Ripple current ※1 (mA rms)	ESR ※2 (mΩ max.)	tan δ ※3	LC ※4 (μA)	
SEPC	2.5	100	5.0	9.0	B9	4180	7	0.10	500	2SEPC100MZ
		330	5.0	9.0		4180	7	0.10	500	2SEPC330MZ
		390	6.3	6.0	C6	3900	10	0.12	500	2SEPC390M
		470	5.0	9.0	B9	4180	7	0.10	500	2SEPC470MZ
		560	5.0	9.0		4180	7	0.10	500	2SEPC560MZ
			6.3	6.0	C6	3900	10	0.12	500	2SEPC560M
			6.3	9.0	C9	5600	7	0.10	500	2SEPC560MW
		820	6.3	9.0	C9	5600	7	0.10	500	2SEPC820MW
			8.0	7.0	E7	5300	8	0.10	500	2SEPC820MD
			8.0	9.0	E9	6100	7	0.10	500	2SEPC820MX
			8.0	9.0		7200	5	0.10	500	2SEPC820MY
			8.0	13.0	E13	6100	7	0.10	500	2R5SEPC820M
	1000	8.0	9.0	E9	6100	7	0.10	500	2SEPC1000MX	
	2700	10.0	13.0	F13	5560	10	0.10	1350	2SEPC2700M	
	4	560	6.3	9.0	C9	5600	7	0.10	500	4SEPC560MW
			8.0	9.0	E9	6100	7	0.10	500	4SEPC560MX
			8.0	13.0	E13	6100	7	0.10	500	4SEPC560M
		680	8.0	13.0		6100	7	0.10	544	4SEPC680M
		820	10.0	13.0	F13	6640	7	0.10	656	4SEPC820M
	6.3	220	6.3	5.5	C55	2980	18	0.12	280	6SEPC220M
			470	6.3	9.0	C9	5600	7	0.10	592
		8.0		9.0	E9	5700	8	0.10	592	6SEPC470MX
		8.0		13.0	E13	5700	8	0.10	592	6SEPC470M
		560	6.3	9.0	C9	5600	7	0.10	705	6SEPC560MW
			8.0	9.0	E9	6100	7	0.10	705	6SEPC560MX
		680	10.0	13.0	F13	6640	7	0.10	857	6SEPC680M
		1000	8.0	7.0	E7	3530	18	0.10	1260	6SEPC1000MD
	1500	10.0	13.0	F13	5560	10	0.10	1890	6SEPC1500M	
	10	270	8.0	7.0	E7	3220	22	0.12	500	10SEPC270MD
	16	100	6.3	6.0	C6	2490	24	0.10	320	16SEPC100M
6.3			9.0	C9	4680	10	0.10	500	16SEPC100MW	
150		8.0	7.0	E7	3220	22	0.12	500	16SEPC150MD	
180		8.0	9.0	E9	5000	10	0.10	576	16SEPC180MX	
		8.0	12.0	E12	4360	16	0.10	576	16SEPC180M	
220		8.0	7.0	E7	4150	13	0.10	500	16SEPC220MD	
270		8.0	9.0	E9	5000	10	0.10	864	16SEPC270MX	
		8.0	12.0	E12	5000	11	0.10	864	16SEPC270M	
470		10.0	13.0	F13	6100	10	0.10	1504	16SEPC470M	

※1: Ripple current (100 kHz/ +105 °C)

※2: ESR (100 kHz to 300 kHz/+20 °C)

※3: tan δ (120 Hz/+20 °C)

※4: After 2 minutes

◆ Please refer to each page in this catalog for "Flow conditions" and "Taping specifications".

Frequency correction factor for ripple current

Frequency	120 Hz ≤ f < 1 kHz	1 kHz ≤ f < 10 kHz	10 kHz ≤ f < 100 kHz	100 kHz ≤ f ≤ 500 kHz
Coefficient	0.05	0.3	0.7	1

Design and specifications are each subject to change without notice. Ask factory for the current technical specifications before purchase and/or use.
Should a safety concern arise regarding this product, please be sure to contact us immediately.

SP-Cap

Guidelines and Precautions
Mounting specifications
Packing specifications

Selection guide

Surface mount type

Catalog EOL models

POSCAP

Guidelines and Precautions
Mounting specifications
Packing specifications

Selection guide

Surface mount type

Catalog Deletion models

Catalog EOL models

OS-CON

Guidelines and Precautions
Mounting specifications
Packing specifications

Selection guide
Line-up
Series system diagram
Size chart

Products list

SVT
SVPT
SVF
SVPK
SXV
SVPG
SVPF
SVPA
SVPC
SVPB
SVPD
SVPS
SVPE
SVQP
SVP
SEK
SEF
SEPG
SXE
SEPF
SEPC
SEQP
SEP

Catalog EOL models

Hybrid

Guidelines and Precautions
Mounting specifications
Packing specifications

Selection guide

Surface mount type

Radial lead type



High voltage(32 V max.)

Guaranteed at 125 °C 1000 h

RoHS compliance, Halogen free

SP-Cap

Guidelines and Precautions
Mounting specifications
Packing specifications

Selection guide

Surface mount type

Catalog EOL models

POSCAP

Guidelines and Precautions
Mounting specifications
Packing specifications

Selection guide

Surface mount type

Catalog Deletion models

Catalog EOL models

OS-CON

Guidelines and Precautions
Mounting specifications
Packing specifications

Line-up
Series system diagram
Size chart

Products list

- SVT
- SVPT
- SVF
- SVPK
- SXV
- SVPG
- SVPF
- SVPA
- SVPC
- SVPB
- SVPD
- SVPS
- SVPE
- SVQP
- SVP

Surface mount type

- SEK
- SEF
- SEPG
- SXE
- SEPF
- SEPC
- SEQP**
- SEP

Radial lead type

Catalog EOL models

Hybrid

Guidelines and Precautions
Mounting specifications
Packing specifications

Selection guide

Surface mount type

Radial lead type

Specifications

Items	Specifications				
	Size code	C6	E7	E12	F8
Category temperature range	-55 °C to +125 °C				
Rated voltage range	4 V to 20 V		4 V to 32 V		4 V to 20 V
Rated capacitance range	22 μF to 150 μF	6.8 μF to 330 μF	18 μF to 560 μF	15 μF to 680 μF	150 μF to 1200 μF
Capacitance tolerance	±20 % (120 Hz/+20 °C)				
Leakage current	Please see the attached characteristics list				
Dissipation factor(tanδ)	Please see the attached characteristics list				
Endurance	+125 °C, 1000 h/+105 °C, 5000 h, rated voltage applied				
	Capacitance change	Within ±20 % of the initial value			
	tanδ	≤ 200 % of the initial limit			
	DC leakage current	Within the initial limit			
Damp heat(Steady state)	+60 °C, 90 % to 95 % RH, 1000 h, No-applied voltage				
	Capacitance change	Within ±20 % of the initial value			
	tanδ	≤ 150 % of the initial limit			
	DC leakage current	Within the initial limit (after voltage processing)			

Marking and Dimensions

※ Depends on the case size.

(unit : mm)

Size code	φD ±0.5	L max	F ±0.5	φd ±0.05
C6	6.3	6.0	2.5	0.45
E7	8.0	7.0	3.5	0.45
E12	8.0	12.0	3.5	0.6
F8	10.0	8.0	5.0	0.5
F13	10.0	13.0	5.0	0.6

Characteristics list

Series	Rated voltage (V)	Rated capacitance (μF)	Case size (mm)		Size code	Specifications					Part number
			φD	L		Ripple current ※1 (mA rms)	Allowable ripple current※1 (mA rms)	ESR ※2 (mΩ max.)	tan δ ※3	LC ※4 (μA)	
SEQP	4	150	6.3	6.0	C6	572	1810	40	0.12	300	4SEQP150M
		330	8.0	7.0	E7	810	2560	35	0.12	660	4SEQP330M
		560	8.0	12.0	E12	1430	4520	13	0.15	448	4SEQP560M
		680	10.0	8.0	F8	1170	3700	25	0.12	544	4SEQP680M
		1200	10.0	13.0	F13	1721	5440	12	0.18	960	4SEQP1200M
	6.3	82	6.3	6.0	C6	537	1700	45	0.12	258	6SEQP82M
		150	8.0	7.0	E7	810	2560	35	0.12	472	6SEQP150M
		330	10.0	8.0	F8	1170	3700	25	0.12	416	6SEQP330M
		470	8.0	12.0	E12	1332	4210	15	0.15	592	6SEQP470M
		820	10.0	13.0	F13	1721	5440	12	0.15	775	6SEQP820M
	10	56	6.3	6.0	C6	537	1700	45	0.12	280	10SEQP56M
		120	8.0	7.0	E7	810	2560	35	0.12	600	10SEQP120M
		270	10.0	8.0	F8	1170	3700	25	0.12	540	10SEQP270M
		330	8.0	12.0	E12	1250	3950	17	0.15	660	10SEQP330M
		560	10.0	13.0	F13	1655	5230	13	0.15	840	10SEQP560M
	16	39	6.3	6.0	C6	512	1620	50	0.10	312	16SEQP39M
		82	8.0	7.0	E7	670	2120	40	0.12	656	16SEQP82M
		150	10.0	8.0	F8	955	3020	30	0.12	480	16SEQP150M
		180	8.0	12.0	E12	1151	3640	20	0.15	576	16SEQP180M
		330	10.0	13.0	F13	1493	4720	16	0.15	792	16SEQP330M
	20	22	6.3	6.0	C6	458	1450	60	0.10	220	20SEQP22M
		47	8.0	7.0	E7	598	1890	45	0.12	470	20SEQP47M
		68	10.0	8.0	F8	759	2400	40	0.12	272	20SEQP68M
		100	8.0	12.0	E12	1050	3320	24	0.15	400	20SEQP100M
		150	10.0	13.0	F13	1367	4320	20	0.15	600	20SEQP150M
	32	6.8	8.0	7.0	E7	440	1400	100	0.10	44	32SEQP6R8M
		15	10.0	8.0	F8	560	1800	80	0.10	96	32SEQP15M
		18	8.0	12.0	E12	790	2500	50	0.12	115	32SEQP18M

※1: Ripple current (100 kHz/ +105 °C < Tx ≤ +125 °C) / Allowable ripple current (100 kHz/ Tx ≤ +105 °C)

※2: ESR (100 kHz to 300 kHz/+20 °C)

※3: tan δ (120 Hz/+20 °C)

※4: After 2 minutes

◆Please refer to each page in this catalog for "Reflow conditions" and "Taping specifications"

Frequency correction factor for ripple current

Frequency	120 Hz ≤ f < 1 kHz	1 kHz ≤ f < 10 kHz	10 kHz ≤ f < 100 kHz	100 kHz ≤ f ≤ 500 kHz
Coefficient	0.05	0.3	0.7	1

SP-Cap

Guidelines and Precautions
Mounting specifications
Packing specifications

Selection guide

Surface mount type

Catalog EOL models

POSCAP

Guidelines and Precautions
Mounting specifications
Packing specifications

Selection guide

Surface mount type

Catalog Deletion models

Catalog EOL models

OS-CON

Guidelines and Precautions
Mounting specifications
Packing specifications

Selection guide
Line-up
Series system diagram
Size chart

Products list

SVT
SVPT
SVF
SVPK
SXV
SVPG
SVPF
SVPA
SVPC
SVPB
SVPD
SVPs
SVPE
SVQP
SVP
SEK
SEF
SEPG
SXE
SEPF
SEPC
SEQP
SEP

Catalog EOL models

Hybrid

Guidelines and Precautions
Mounting specifications
Packing specifications

Selection guide

Surface mount type

Radial lead type



Standard

Guaranteed at 105 °C 3000 h

RoHS compliance, Halogen free

SP-Cap

Guidelines and Precautions
Mounting specifications
Packing specifications

Selection guide

Surface mount type

Catalog EOL models

POSCAP

Guidelines and Precautions
Mounting specifications
Packing specifications

Selection guide

Surface mount type

Catalog Deletion models

Catalog EOL models

OS-CON

Guidelines and Precautions
Mounting specifications
Packing specifications

Line-up
Series system diagram
Size chart
Selection guide

Products list

- SVT
- SVPT
- SVF
- SVPK
- SXV
- SVPG
- SVPF
- SVPA
- SVPC
- SVPB
- SVPD
- SVPS
- SVPE
- SVQP
- SVP
- SEK
- SEF
- SEPG
- SXE
- SEPF
- SEPC
- SEQP
- SEP**

Surface mount type

Radial lead type

Catalog EOL models

Hybrid

Guidelines and Precautions
Mounting specifications
Packing specifications

Selection guide

Surface mount type

Radial lead type

Specifications

Items	Specifications				
	Size code	C6	E7	E12	F8
Category temperature range	-55 °C to +105 °C				
Rated voltage range	4 V to 20 V		2.5 V to 20 V	4 V to 20 V	2.5 V to 20 V
Rated capacitance range	22 μF to 150 μF	33 μF to 330 μF	100 μF to 680 μF	56 μF to 680 μF	150 μF to 1500 μF
Capacitance tolerance	±20 % (120 Hz/+20 °C)				
Leakage current	Please see the attached characteristics list				
Dissipation factor(tanδ)	Please see the attached characteristics list				
Endurance	+105 °C, 3000 h, rated voltage applied (2.5 V products : 2000 h)				
	Capacitance change	Within ±20 % of the initial value			
	tanδ	≤ 150 % of the initial limit			
	DC leakage current	Within the initial limit			
Damp heat (Steady state)	+60 °C, 90 % to 95 % RH, 1000 h, No-applied voltage				
	Capacitance change	Within ±20 % of the initial value			
	tanδ	≤ 150 % of the initial limit			
	DC leakage current	Within the initial limit (after voltage processing)			

Marking and Dimensions

Lot. No.
Series code※
R. capacitance (μF)
R. voltage (V)

※ Depends on the case size.

(unit : mm)

Size code	φD ±0.5	L max	F ±0.5	φd ±0.05
C6	6.3	6.0	2.5	0.45
E7	8.0	7.0	3.5	0.45
E12	8.0	12.0	3.5	0.6
F8	10.0	8.0	5.0	0.5
F13	10.0	13.0	5.0	0.6

Characteristics list

Series	Rated voltage (V)	Rated capacitance (μF)	Case size (mm)		Size code	Specifications				Part number
			φD	L		Ripple current ※1 (mA rms)	ESR ※2 (mΩ max.)	tan δ ※3	LC ※4 (μA)	
SEP	2.5	680	8.0	12.0	E12	4520	13	0.15	340	2R5SEP680M
		1500	10.0	13.0	F13	5440	12	0.18	750	2R5SEP1500M
	4	100	6.3	6.0	C6	1810	40	0.12	200	4SEP100M
		150	6.3	6.0		1810	40	0.12	300	4SEP150M
		220	8.0	7.0	E7	2560	35	0.12	440	4SEP220M
		330	8.0	7.0		2560	35	0.12	660	4SEP330M
		470	10.0	8.0	F8	3700	25	0.12	376	4SEP470M
		560	8.0	12.0	E12	4520	13	0.15	448	4SEP560M
		680	10.0	8.0	F8	3700	25	0.12	544	4SEP680M
		1200	10.0	13.0	F13	5440	12	0.18	960	4SEP1200M
	6.3	82	6.3	6.0	C6	1700	45	0.12	258	6SEP82M
		150	8.0	7.0	E7	2560	35	0.12	472	6SEP150M
		330	10.0	8.0	F8	3700	25	0.12	416	6SEP330M
		470	8.0	12.0	E12	4210	15	0.15	592	6SEP470M
		820	10.0	13.0	F13	5440	12	0.15	775	6SEP820M
	10	56	6.3	6.0	C6	1700	45	0.12	280	10SEP56M
		120	8.0	7.0	E7	2560	35	0.12	600	10SEP120M
		270	10.0	8.0	F8	3700	25	0.12	540	10SEP270M
		330	8.0	12.0	E12	3950	17	0.15	660	10SEP330M
		560	10.0	13.0	F13	5230	13	0.15	840	10SEP560M
	16	39	6.3	6.0	C6	1620	50	0.10	312	16SEP39M
		82	8.0	7.0	E7	2120	40	0.12	656	16SEP82M
		150	10.0	8.0	F8	3020	30	0.12	480	16SEP150M
		180	8.0	12.0	E12	3640	20	0.15	576	16SEP180M
		330	10.0	13.0	F13	4720	16	0.15	792	16SEP330M
	20	22	6.3	6.0	C6	1450	60	0.10	220	20SEP22M
		33	8.0	7.0	E7	1890	45	0.12	330	20SEP33M
		47	8.0	7.0		1890	45	0.12	470	20SEP47M
		56	10.0	8.0	F8	2400	40	0.12	224	20SEP56M
		68	10.0	8.0		2400	40	0.12	272	20SEP68M
		100	10.0	8.0		2570	35	0.12	400	20SEP100MX
			8.0	12.0	E12	3320	24	0.15	400	20SEP100M
150		10.0	13.0	F13	4320	20	0.15	600	20SEP150M	

※1: Ripple current (100 kHz/ +105 °C)

※2: ESR (100 kHz to 300 kHz/+20 °C)

※3: tan δ (120 Hz/+20 °C)

※4: After 2 minutes

◆Please refer to each page in this catalog for "Flow conditions" and "Taping specifications".

Frequency correction factor for ripple current

Frequency	120 Hz ≤ f < 1 kHz	1 kHz ≤ f < 10 kHz	10 kHz ≤ f < 100 kHz	100 kHz ≤ f ≤ 500 kHz
Coefficient	0.05	0.3	0.7	1

SP-Cap

Guidelines and Precautions
Mounting specifications
Packing specifications

Selection guide

Surface mount type

POSCAP

Guidelines and Precautions
Mounting specifications
Packing specifications

Selection guide

Surface mount type

Catalog Deletion models

Catalog EOL models

OS-CON

Guidelines and Precautions
Mounting specifications
Packing specifications

Selection guide
Line-up
Series system diagram
Size chart

Products list

SVT
SVPT
SVF
SVPK
SXV
SVPF
SVPA
SVPB
SVPD
SVPS
SVPE
SVQP
SVP
SEK
SEF
SEPG
SXE
SEPF
SEPC
SEQP
SEP

Catalog EOL models

Hybrid

Guidelines and Precautions
Mounting specifications
Packing specifications

Selection guide

Surface mount type

Radial lead type

Catalog EOL models

SP-Cap

Guidelines and Precautions
Mounting specifications
Packing specifications

Selection guide

Surface mount type

Catalog EOL models

POSCAP

Guidelines and Precautions
Mounting specifications
Packing specifications

Selection guide

Surface mount type

Catalog Deletion models

Catalog EOL models

OS-CON

Guidelines and Precautions
Mounting specifications
Packing specifications

Line-up
Series system diagram
Size chart
Selection guide

Products list

- SVT
- SVPT
- SVF
- SVPK
- SXV
- SVPG
- SVPF
- SVPA
- SVPC
- SVPB
- SVPD
- SVPS
- SVPE
- SVQP
- SVP
- SEK
- SEF
- SEPG
- SXE
- SEPF
- SEPC
- SEQP
- SEP

Surface mount type

Radial lead type

Catalog EOL models

Hybrid

Guidelines and Precautions
Mounting specifications
Packing specifications

Selection guide

Surface mount type

Radial lead type

The following table is a list of our parts which have been deleted from our catalogs. If you are using any of the following models, please substitute with the suggested alternative model/series.

Also, we have announced the end of life of aluminum solid capacitors with organic semiconductive electrolyte. We hope alternative parts (Aluminum Solid Capacitors with Organic Semiconductive Electrolyte) will continue to serve your needs.

Thank you very much.

● The list of alternatives for higher voltage

Series	Size code	Models for deletion	Year of deletion	Alternative model
SVP	A5	6SVP15M	2002	10SVP15M
		4SVP22M	2002	6SVP22M
	B6	10SVP22M	2002	16SVP22M
		6SVP33M	2002	10SVP33M
		6SVP56M	2002	10SVP56M
	C6	4SVP100M	2002	6SVP82M
		10SVP82M	2002	4SVP150MX
		6SVP120M	2002	16SVP82M
		6SVP150M	2002	10SVP120M
	E7	4SVP150M	2002	10SVP150MX
		4SVP220M	2002	10SVP150MX
		4SVP470M	2002	6SVP220MX
SVQP	E7	6SVQP150M	2002	10SVQP150M
		4SVQP220M	2007	6SVQP220M
SEPC	C9	2SEPC330MW	2007	2SEPC560MW

● The list of alternatives to 25V products

Series	Size code	Models for deletion	Year of deletion	Alternative model
SVP	C6	25SVP6R8M	2013	SVPD Series SVPF Series
	E7	25SVP10M	2013	
	F8	25SVP22M	2013	
	E12	25SVP33M	2013	
	F12	25SVP56M	2013	
SEP	C6	25SEP6R8M	2013	SEPF Series
	E7	25SEP10M	2013	
	F8	25SEP22M	2013	
	E12	25SEP33M	2013	
	F13	25SEP56M	2013	

● End of life/ Aluminum Solid Capacitors with Organic Semiconductive Electrolyte

Series	Size code	Status
SZP	All size	EOL
SF		
SP		
SC		
SA		
SL		
SH		
S		
SG		
SPA		
SM		
SN		
SV		



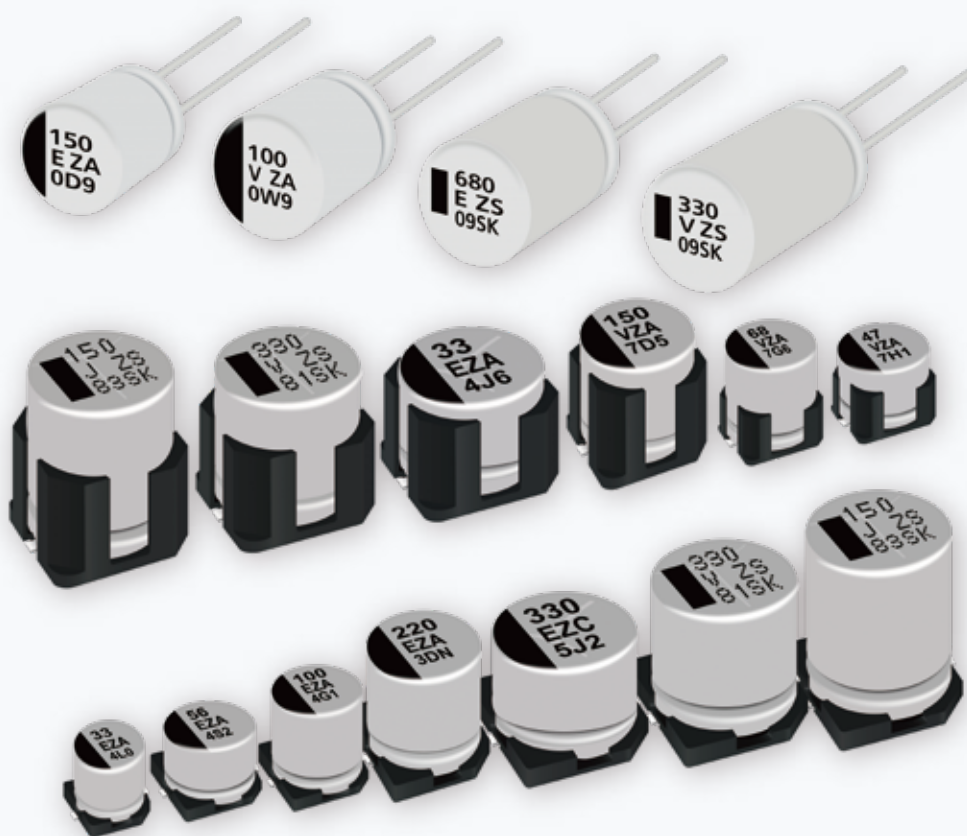

Conductive Polymer Hybrid Aluminum Electrolytic Capacitors

Hybrid

INDEX

Guidelines and Precautions	P123
Mounting specifications / Packing specifications	P127
Selection guide	P130
Products list	P133

SP-Cap

Guidelines and Precaution
Mounting specifications
Packing specifications

Selection guide

Surface mount type

Catalog EOL models

POSCAP

Guidelines and Precautions
Mounting specifications
Packing specifications

Selection guide

Surface mount type

Catalog Deletion models

Catalog EOL models

OS-CON

Guidelines and Precautions
Mounting specifications
Packing specifications

Selection guide

Surface mount type

Radial lead type

Catalog EOL models

Hybrid

Guidelines and Precautions
Mounting specifications
Packing specifications

Selection guide
Line-up
Series system diagram
Products list

Surface mount type
ZA
ZC
ZK
ZKU
ZT
ZS
ZSU
ZU
ZE
ZF

Radial lead type
ZA-A
ZC-A
ZK-A
ZKU-A
ZT-A
ZS-A
ZSU-A
ZE-A
ZF-A

Applications

Main market

Communications infrastructure

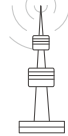

Automotive

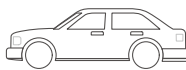

Industrial equipment

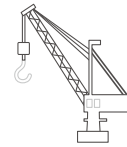

Desktop computer



Audio / Visual

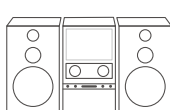

Server



Home appliance

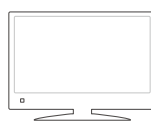

Industrial robot

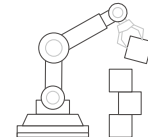

Guidelines and Precautions

SP-Cap

Guidelines and Precautions
Mounting specifications
Packing specifications

Selection guide

Surface mount type

Catalog EOL models

POSCAP

Guidelines and Precautions
Mounting specifications
Packing specifications

Selection guide

Surface mount type

Catalog Deletion models

Catalog EOL models

OS-CON

Guidelines and Precautions
Mounting specifications
Packing specifications

Selection guide

Surface mount type

Catalog EOL models

Hybrid

Guidelines and Precautions

Mounting specifications
Packing specifications

Line-up
Series system diagram

Products list

ZA

ZC

ZK

ZKU

ZT

ZS

ZSU

ZU

ZE

ZF

ZA-A

ZC-A

ZK-A

ZKU-A

ZT-A

ZS-A

ZSU-A

ZE-A

ZF-A



Application Guidelines

1. Circuit design

1-1 Operating temperature and frequency

Electrical characteristics of the capacitor are likely to change due to variation in temperature and/or frequency. Circuit designers should take these changes into consideration.

(1) Effects of operating temperature on electrical parameters

At higher temperatures :Leakage current increases

At lower temperatures :Hybrid type has smaller capacitance and larger $\tan \delta$.

Other aluminum electrolytic capacitors have smaller capacitance, larger $\tan \delta$, and larger impedance as well as equivalent series resistance (ESR).

(2) Effects of frequency on electrical parameters

At higher frequency capacitance and impedance decrease while $\tan \delta$ increases.

At lower frequency, heat generated by ripple current will rise due to an increase in equivalent series resistance (ESR).

1-2 Operating temperature and life expectancy

(1) Expected life is affected by operating temperature. Generally, each 10 °C reduction in temperature will double the expected life. Use capacitors at the lowest possible temperature below the upper category temperature.

(2) If operating temperatures exceed the upper category limit, rapid deterioration of electrical parameter will occur and irreversible damage will result.

Measure not only the ambient temperature but also the surface temperature of the capacitor's case top, which has effects of ripple current and radiated heat from power transistors, IC's, and/or resistors.

Avoid placing components, which could conduct heat to the capacitor from the back side of the circuit board.

(3) The formula for calculating expected life is as follows

$$L_2 = L_1 \times 2^{\frac{T_1 - (T_2 + \Delta T)}{10}} \quad * \text{ where } T_1 \geq T_2$$

L_1 : Guaranteed life (h) at temperature, T_1 °C

L_2 : Expected life (h) at temperature, T_2 °C

T_1 : Upper category temperature (°C) *Hybrid type : + temperature rise due to rated ripple current

T_2 : Actual operating temperature, ambient temperature

ΔT : Temperature rise due to ripple current (°C)

(4) Using the capacitor beyond the rated lifetime will result in short circuit, electrolyte leak, vent open, and large deterioration of characteristics. The lifetime cannot exceed 15 years due to aging of sealing rubber.

(5) If the capacitor is used in a high temperature condition for a long time, micro cracks may appear on the surface of sealing rubber, and/or capacitor case exterior may become brownish in color, but the product reliability will not be influenced.

1-3 Load conditions to avoid

The following load conditions will cause rapid deterioration of capacitor's electrical characteristics.

In addition, instantaneous heating and gas generation within the capacitor may cause an operation of pressure relief vent, and that results in electrolyte leaks, explosion and/or fire ignition.

The leaked electrolyte is combustible and electrically conductive.

(1) Reverse Voltage

DC capacitors have polarity. Therefore, do not apply the reverse voltage. Find the correct polarity before insertion.

(2) Charge / Discharge Applications

General purpose capacitors are not suitable for use in repeating charge/discharge applications. For such applications, consult a sales representative with actual application condition.

Rush current must not exceed 100 A.

(3) ON-OFF circuit

When using capacitors in circuit where ON-OFF switching is repeated more than 10,000 times a day, consult a sales representative with actual application condition for an appropriate choice of capacitors.

(4) Over voltage

Do not apply a voltage exceeding the rated voltage. The rated surge voltage can be applied only for a short time. Make sure that a sum of the DC voltage and the superimposed AC ripple voltage does not exceed the rated voltage.

(5) Ripple Current

Do not apply ripple currents exceeding the rated value. Make sure that rated ripple currents superimposed on low DC bias voltages do not cause reverse voltage conditions. Even if the current is below the rated ripple current, using the capacitor for longer than the rated lifetime will cause ESR increase and internal generation of heat, which may eventually lead to vent open, bulging of case/rubber, electrolyte leak, short circuit, explosion, or ignition in the worst case.

1-4 Connections in parallel

Because the impedance of the capacitor and PCB's wiring are very close, various impedance values may cause unbalanced ripple current loads among parallel capacitors. Combine the same part number and wire them carefully to minimize the potential risk of an excessive ripple current concentrating to one capacitor of the smallest impedance.

The capacitors cannot be used in series.

1-5 Capacitor mounting considerations

(1) For double sided circuit boards, avoid wiring patterns passing between the mounted capacitor and the circuit board. When a radial lead type capacitor is dipped into a solder bath, an excess solder may deposit under the capacitor by capillary action, causing short circuit between anode and cathode terminals. Also, lead holes must be placed with special care for radial lead type capacitors because laminate on capacitor's surface may become damaged during flow process.

(2) The pitch between circuit board holes should match the lead wire pitch of the radial lead type capacitors within the specified tolerances. Unmatched pitch may cause an excessive stress on lead wires during the insertion process and result in short/open circuit, increased leakage current, or electrolyte leak.

- (3) Clearance for case mounted pressure relief ($\geq \phi 10$ mm)
Capacitors with case mounted pressure relief require sufficient clearance to allow for proper pressure relief operation. The minimum clearance are dependent on capacitor diameters as follows.
* $\geq \phi 10$ mm : 2 mm minimum
- (4) Wiring near the pressure relief ($\geq \phi 10$ mm)
Avoid locating high voltage or high current wiring or circuit board paths above the pressure relief. Flammable, high temperature gas that exceeds 100 °C may be released which could dissolve the wire insulation and ignite.
- (5) Circuit board patterns under the capacitor
Avoid circuit board runs under the capacitor, as an electrical short can occur due to an electrolyte leakage.
- (6) Resonant vibration after circuit board's production may make a heavy load on the capacitor and cause rapid change in characteristics and/or capacitor's break.

1-6 Electrical insulation

Electrically isolate the capacitor's case from cathode terminals, as well as circuit patterns.

1-7 Capacitor coating

The laminate coating is intended for marking and identification purposes and is not meant to electrically insulate the capacitor. Its color may become brownish in a high-temperature condition, but the marking appearance and electrical characteristics will not be influenced.

2. Capacitor handling techniques

2-1 Considerations before using

- (1) Capacitors have a finite life. Do not reuse or recycle capacitors from used equipment.
- (2) Transient recovery voltage may be generated in the capacitor due to dielectric absorption.
If required, this voltage can be discharged with a resistor with a value of about 1 kΩ.
- (3) Capacitors stored for a long period of time may exhibit an increase in leakage current.
This can be corrected by gradually applying rated voltage in series with a resistor of approximately 1 kΩ.
- (4) If capacitors are dropped, they can be damaged mechanically or electrically. Avoid using dropped capacitors.
- (5) Dented or crushed capacitors should not be used.
The seal integrity can be damaged and loss of electrolyte/ shortened life can result.

2-2 Capacitor insertion

- (1) Verify the correct capacitance and rated voltage of the capacitor.
- (2) Verify the correct polarity of the capacitor before insertion.
- (3) Verify the correct terminal dimension and land pattern size for surface mount type, or holes' pitch for radial lead type before mount to avoid short circuit, stress on terminals, and/or lack of terminal strength.
- (4) Excessive mounting pressure can cause high leakage current, short circuit, or disconnection.
- (5) When using a mounter for radial lead type, avoid cutter wear and acute angle of lead-bending with respect to circuit board. That may create excessive stress and pull the lead to damage the capacitor.

2-3 Reflow soldering (for surface mount type)

- (1) Surface-mount type capacitor are exclusively for reflow soldering.
When reflow solder is used an ambient heat condition system such as the simultaneous use of infrared and hot-air is recommended.
- (2) Observe proper soldering conditions (temperature, time, etc.). Do not exceed the specified limits.
If the peak temperature is high or if the heating time is long, it may cause deterioration of the electrical characteristics and life characteristics.
Recommended soldering condition is a guideline for ensuring the basic characteristics of the components, but not for the stable soldering conditions. Conditions for proper soldering should be set up according to individual conditions.
*The Temperature on Capacitor top shall be measured by using thermal couple that is fixed firmly by epoxy glue.
- (3) In case of use in 2 times reflow, 2nd reflow must be done when the capacitor's temperature return back to normal level.
- (4) In our recommended reflow condition, the case discoloration and the case swelling might be slightly generated.
But please acknowledge that these two phenomena do not influence the reliability of the product.
- (5) The crack on top marking might be occurred by reflow heat stress.
But please acknowledge that it does not influence the reliability of the product.
- (6) VPS (Vapor Phase Soldering) reflow can cause significant characteristics change and/ or mounting failure due to deformation by acute temperature rise.
VPS is acceptable provided that the process does not exceed recommended reflow profile and temperature rise is less than 3 °C / sec.
Please contact Panasonic for detailed conditions.
- (7) The vibration-proof capacitors of size $\phi 6.3$ has support terminals extending from the bottom side to the lead edge. Then, make sure to find appropriate soldering conditions to form fillet on the support terminals if required for appearance inspection. However, even if sufficient solder fillets are not observed, the reliability of vibration-proof will not be lowered because the support terminals on the bottom side enhance the solder joint to circuit board.

2-4 Flow soldering (for radial type)

- (1) Radial lead type capacitors cannot apply to reflow soldering.
- (2) Do not immerse the capacitor body into the solder bath as excessive internal pressure could result.
- (3) Apply proper soldering conditions (temperature, time, etc.). Do not exceed the specified limits.
- (4) Do not allow other parts or components to touch the capacitor during soldering.
- (5) When mounting the radial type being touched to PCB, be sure to check the appearance of solder under the sealing rubber, which does not have an airflow structure.

SP-Cap

Guidelines and Precaution
Mounting specifications
Packing specifications

Selection guide

Surface mount type

Catalog EOL models

POSCAP

Guidelines and Precautions
Mounting specifications
Packing specifications

Selection guide

Surface mount type

Catalog Deletion models

Catalog EOL models

OS-CON

Guidelines and Precautions
Mounting specifications
Packing specifications

Selection guide

Surface mount type

Radial lead type

Catalog EOL models

Hybrid

Guidelines and Precautions
Mounting specifications
Packing specifications

Selection guide	Line-up
	Series system diagram
Surface mount type	Products list
	ZA
	ZC
	ZK
	ZKU
	ZT
	ZS
	ZSU
	ZU
	ZE
ZF	
Radial lead type	ZA-A
	ZC-A
	ZK-A
	ZKU-A
	ZT-A
	ZS-A
	ZSU-A
ZE-A	
ZF-A	

Guidelines and Precautions

SP-Cap

Guidelines and Precautions
Mounting specifications
Packing specifications

Selection guide

Surface mount type

Catalog EOL models

POSCAP

Guidelines and Precautions
Mounting specifications
Packing specifications

Selection guide

Surface mount type

Catalog Deletion models

Catalog EOL models

OS-CON

Guidelines and Precautions
Mounting specifications
Packing specifications

Selection guide

Surface mount type

Radial lead type

Catalog EOL models

Hybrid

Guidelines and Precautions

Mounting specifications
Packing specifications

Line-up

Series system diagram

Products list

Products list	Selection guide
ZA	
ZC	
ZK	
ZKU	
ZT	Surface mount type
ZS	
ZSU	
ZU	
ZE	
ZF	
ZA-A	Radial lead type
ZC-A	
ZK-A	
ZKU-A	
ZT-A	
ZS-A	
ZSU-A	
ZE-A	
ZF-A	

2-5 Manual soldering

- (1) Apply soldering conditions (temperature and time) based on the specification, or do not exceed temperature of 350 °C for 3 seconds.
- (2) If a soldered capacitor must be removed and reinserted, avoid excessive stress on the capacitor leads.
- (3) Avoid physical contacts between the tip of the soldering iron and capacitors to prevent capacitor failure.
- (4) When bending lead wires of radial type capacitors to match the hole pitch on PCB, avoid applying excessive stress to the capacitor body.

2-6 Capacitor handling after soldering

- (1) Avoid moving the capacitor after soldering to prevent excessive stress on the lead wires where they enter the seal. The capacitor may break from element portion due to a torque at outer rim, causing a large stress to terminals.
- (2) Do not use the capacitor as a handle when moving the circuit board assembly. The total weight of the board would apply to element portion through terminals, and the capacitor may break.
- (3) Avoid striking the capacitor after assembly to prevent failure due to excessive shock. The capacitor may break due to excessive shock or load above specified range.

2-7 Circuit board cleaning

- (1) Circuit boards can be immersed or ultrasonically cleaned using suitable cleaning solvents for up to 5 minutes and up to 60 °C maximum temperatures. The boards should be thoroughly rinsed and dried. The use of ozone depleting cleaning agents is not recommended for the purpose of protecting our environment.
- (2) Avoid using the following solvent groups unless specifically allowed in the specification;
 - (a) Halogenated based solvents : may permeate the seal and cause internal corrosion.
Especially, 1-1-1 trichloroethane must not be used on any aluminum electrolytic capacitors.
 - (b) Alkaline based solvents : may dissolve and react to the aluminum case.
 - (c) Petroleum based solvents : may deteriorate the sealing rubber
 - (d) Xylene : may deteriorate the sealing rubber
 - (e) Acetone : may erase the markings on the capacitor top
- (3) A thorough drying after cleaning is required to remove residual cleaning solvents that may be trapped between the capacitor and the circuit board. Avoid drying temperatures, which exceed the Upper category temperature of the capacitor.
- (4) Monitor the contamination levels of cleaning solvents during use in terms of electrical conductivity, pH, specific gravity, and water content. Inside the capacitor may corrode with high density of chlorine. Control the flux density in the cleaning agent to be less than 2 mass%. the flux density in the cleaning agent to be less than 2 mass%.
- (5) Depending on the cleaning method, the marking on a capacitor may be erased or blurred.
 - ※ Please consult us if you are not certain about acceptable cleaning solvents or cleaning methods.

2-8 Mounting adhesives and coating agents

When using mounting adhesives or coating agents to control humidity, avoid using materials containing halogenated solvents. Also, avoid the use of chloroprene based polymers. Cure or dry out the coating agents thoroughly, and do not leave any solvents. Make sure to dry out cleaning agents completely immediately after washing the circuit board if the capacitors are mounted afterward, so that the solvents are not left under the capacitor body. Leave more than 1/3 of the sealing portion open, and do not cover that portion with any adhesives or coating.

2-9 Potting and molding

Potting and molding processes cannot be recommended. They have potential risks to change the capacitor's performance and reliability due to injection pressure, diffused material into the capacitor, as well as heat accumulation by covered resin. Also, evaporated electrolyte may remain inside the resin, then turn to liquid, and possibly short circuit PCB patterns.

2-10 Fumigation

In exporting electronic appliances with aluminum electrolytic capacitors, in some cases fumigation treatment using such halogen compound as methyl bromide is conducted for wooden boxes. If such boxes are not dried well, the halogen left in the box is dispersed while transported and enters in the capacitors inside. This possibly causes electrical corrosion of the capacitors. Therefore, after performing fumigation and drying make sure that no halogen is left. Don't perform fumigation treatment to the whole electronic appliances packed in a box.

2-11 Flux

If you use a halogen type (Chlorine type, Bromine type, etc.) high-activity flux, please use it after confirmation in advance, as it may have an impact on performance and reliability of this product due to the residue of the flux.

3. Precautions for using capacitors

3-1 Environmental conditions

Capacitors should not be stored or used in the following environments.

- (1) Exposure to temperatures above the upper category or below the lower category temperature of the capacitor.
- (2) Direct contact with water, salt water, or oil.
- (3) High humidity conditions where water could condense on the capacitor.
- (4) Exposure to toxic gases such as hydrogen sulfide, sulfuric acid, nitric acid, chlorine, chlorine compound, bromine, bromine compound or ammonia.
- (5) Exposure to ozone, radiation, or ultraviolet rays.
- (6) Vibration and shock conditions exceeding specified requirements.

Even within the specified requirements, a large vibration acceleration may be applied due to resonance, so be sure to evaluate and confirm with the actual product.

3-2 Electrical precautions

- (1) Avoid touching the terminals of a capacitor as a possible electric shock could result.
The exposed aluminum case is not insulated and could also cause electric shock if touched.
- (2) Avoid short circuiting the capacitor terminals with conductive materials such as acids or alkaline solutions.
- (3) Electrical characteristics may largely change if a silicon material with low molecular-weight siloxane is used near the capacitor.

4. Emergency procedures

- (1) If the pressure relief of the capacitor operates, immediately turn off the equipment and disconnect from the power source. This will minimize an additional damage caused by the vaporizing electrolyte.
- (2) Avoid contact with the escaping electrolyte gas, which can exceed 100 °C temperatures.
If electrolyte or gas enters the eye, immediately flush the eye with large amounts of water.
If electrolyte or gas is ingested by mouth, gargle with water.
If electrolyte contacts the skin, wash with soap and water.

5. Long term storage

- (1) Leakage current of a capacitor tends to increase after a long-term storage due to dielectric dissolution, and very high current may flow at the first voltage load. However, applying voltage will form the dielectric, and the leakage current will decrease. Expiration date is 42 months from the outgoing inspection date.
Storage condition is to keep in room temperature (5 °C to 35 °C) and humidity (45 % to 85 %) with no direct sunshine.
- (2) Environmental Conditions
Do not store under condition outside the area described in the specification, and also under conditions listed below.
 - (a) Exposure to temperatures above the upper category or below the lower category temperature of the capacitor.
 - (b) Direct contact with water, salt water, or oil.
 - (c) High humidity conditions where water could condense on the capacitor.
 - (d) Exposure to toxic gases such as hydrogen sulfide, sulfuric acid, nitric acid, chlorine, chlorine compound, bromine, bromine compound or ammonia.
 - (e) Exposure to ozone, radiation, or ultraviolet rays.
 - (f) Vibration and shock conditions exceeding specified requirements.

6. Capacitor disposal

When disposing capacitors, use one of the following methods.

- (1) Incinerate after crushing the capacitor or puncturing the can wall (to prevent explosion due to internal pressure rise).
- (2) Dispose as solid waste.

NOTE : Local laws may have specific disposal requirements which must be followed.

The precautions in using aluminum electrolytic capacitors follow the "Safety application guide for the use in fixed aluminum electrolytic capacitors for electronic equipment", RCR-2367D issued by JEITA in October 2017. Please refer to the above application guide for details.

■ AEC-Q200 compliant

The products are tested based on all or part of the test conditions and methods defined in AEC-Q200. Please consult with Panasonic for the details of the product specification and specific evaluation test results, etc., and please review and approve Panasonic's product specification before ordering.

Intellectual property right

We, Panasonic Group are providing the product and service that customers can use without anxiety, and are working positively on the protection of our products under intellectual property rights.

Representative patents relating to **Conductive Polymer Hybrid Aluminum Electrolytic Capacitors** are as follows:

US Patent No. 7497879, 7621970, 9208954, 9595396, 9966200, 10262806, 10453618, 10559432, 10679800, 10685788, 10790095
JP Patent No. 5360250
EP Patent No. 1808875, 2698802

SP-Cap

Guidelines and Precautions
Mounting specifications
Packing specifications

Selection guide

Surface mount type

Catalog EOL models

POSCAP

Guidelines and Precautions
Mounting specifications
Packing specifications

Selection guide

Surface mount type

Catalog Deletion models

Catalog EOL models

OS-CON

Guidelines and Precautions
Mounting specifications
Packing specifications

Selection guide

Surface mount type

Radial lead type

Catalog EOL models

Hybrid

Guidelines and Precautions
Mounting specifications
Packing specifications

Selection guide
Line-up
Series system diagram
Products list

Surface mount type	ZA
	ZC
	ZK
	ZKU
	ZT
	ZS
	ZSU
	ZU
	ZE
	ZF
Radial lead type	ZA-A
	ZC-A
	ZK-A
	ZKU-A
	ZT-A
	ZS-A
	ZSU-A
ZE-A	
ZF-A	

Mounting specifications

Recommended reflow soldering (Surface mount type)

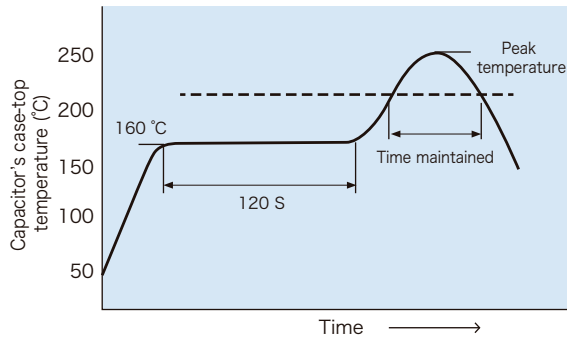

Size code	C, D, D8	F, G, G12, G16	
Peak temperature	260 °C (255 °C)	245 °C	260 °C
Time in peak temperature	≥ 250 °C 5 s (10 s)	≥ 240 °C 10 s	≥ 250 °C 5 s
Time maintained	≥ 230 °C 30 s	≥ 230 °C 30 s	≥ 230 °C 30 s
	≥ 217 °C 40 s	≥ 217 °C 40 s	≥ 217 °C 40 s
	≥ 200 °C 70 s	≥ 200 °C 70 s	≥ 200 °C 70 s
Reflow cycles	2 times	2 times	1 time

※For reflow, use a thermal condition system such as infrared radiation (IR) or hot blast.
※Reflow temperature is measured on capacitor's case top.

Flow soldering condition (Radial lead type)

	Temperature	Time	Flow number
Soldering condition	260°C + 5°C or less	10 sec +1 sec or less	1 time

Dimensions (Vibration-proof products)

The size and shape are different from standard products.

- Size code: D, D8

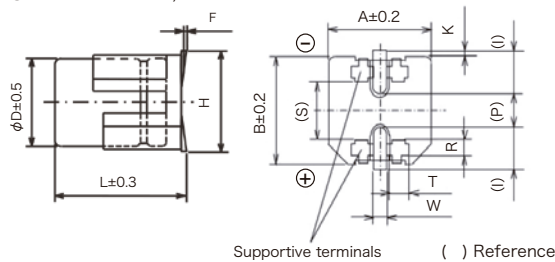

Supportive terminals () Reference

(Unit : mm)

Size code	φ D	L	A, B	H max.	F	I	W	P	K	R	S	T
D	6.3	6.1	6.6	7.8	0 to +0.15	2.4	0.65±0.1	2.2	0.35 ^{+0.15} _{-0.20}	1.1±0.2	3.3	1.05±0.2
D8	6.3	8.0	6.6	7.8	0 to +0.15	2.4	0.65±0.1	2.2	0.35 ^{+0.15} _{-0.20}	1.1±0.2	3.3	1.05±0.2

- Size code: F, G, G12, G16

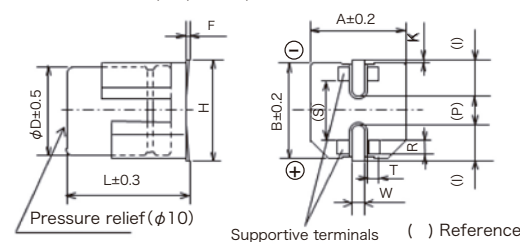

Supportive terminals () Reference

(Unit : mm)

Size code	φ D	L	A, B	H max.	F	I	W	P	K	R	S	T
F	8.0	10.5	8.3	10.0	0 to +0.15	3.4	1.2±0.2	3.1	0.7±0.2	0.7±0.2	5.3	1.3±0.2
G	10.0	10.5	10.3	12.0	0 to +0.15	3.5	1.2±0.2	4.6	0.7±0.2	0.7±0.2	6.9	1.3±0.2
G12	10.0	12.8	10.3	11.0±0.2	0 to +0.15	3.2	1.2±0.2	4.6	---	0.7±0.2	6.9	1.3±0.2
G16	10.0	16.8	10.3	11.0±0.2	0 to +0.15	3.2	1.2±0.2	4.6	---	0.7±0.2	6.9	1.3±0.2

SP-Cap

Guidelines and Precautions
Mounting specifications
Packing specifications

Selection guide

Surface mount type

POSCAP

Guidelines and Precautions
Mounting specifications
Packing specifications

Selection guide

Surface mount type

Catalog Deletion models
Catalog EOL models

OS-CON

Guidelines and Precautions
Mounting specifications
Packing specifications

Selection guide

Surface mount type

Radial lead type

Catalog EOL models

Hybrid

Guidelines and Precautions
Mounting specifications
Packing specifications

Line-up
Series system diagram
Products list

Surface mount type	Radial lead type
ZA	ZA-A
ZC	ZC-A
ZK	ZK-A
ZKU	ZKU-A
ZT	ZT-A
ZS	ZS-A
ZSU	ZSU-A
ZU	ZU-A
ZE	ZE-A
ZF	ZF-A

Land/Pad pattern

The circuit board land/pad pattern size for chip capacitors is specified in the following table. The land pitch influences installation strength.

Standard products

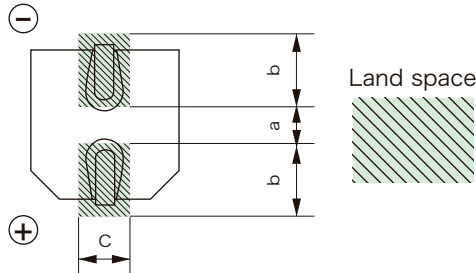

Follow your design rules for mounting conditions, solderability, and fitting strength if some exists in order to determine the land pattern.

(Unit : mm)

Size code	a	b	c
C (ϕ 5xL5.8)	1.5	2.8	1.6
D (ϕ 6.3xL5.8)	1.8	3.2	1.6
D8 (ϕ 6.3xL7.7)	1.8	3.2	1.6
F (ϕ 8xL10.2)	3.1	4.0	2.0
G (ϕ 10xL10.2)	4.6	4.1	2.0
G12 (ϕ 10xL12.5)	4.6	4.1	2.0
G16 (ϕ 10xL16.5)	4.6	4.1	2.0

Larger dimension of "a" may prevent back fillet from being formed adequately to obtain required solder strength.

Vibration-proof products

● Size code: D, D8

● Size code: F, G, G12, G16

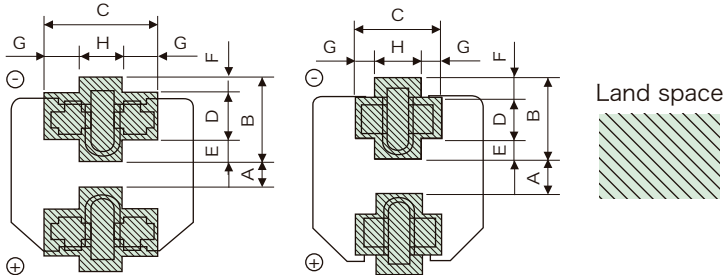

※Take mounting conditions, solderability and fitting strength into consideration when selecting parts for your design.

(Unit : mm)

Size code	A	B	C	D	E	F	G	H
D (ϕ 6.3xL6.1)	1.2	3.6	3.2	2.0	0.95	0.65	1.0	1.2
D8 (ϕ 6.3xL8.0)	1.2	3.6	3.2	2.0	0.95	0.65	1.0	1.2
F (ϕ 8xL10.5)	2.7	4.0	4.7	1.3	1.0	1.7	1.1	2.5
G (ϕ 10xL10.5)	3.9	4.4	4.7	1.3	1.2	1.9	1.1	2.5
G12 (ϕ 10xL12.8)	3.9	4.4	4.7	1.3	1.2	1.9	1.1	2.5
G16 (ϕ 10xL16.8)	3.9	4.4	4.7	1.3	1.2	1.9	1.1	2.5

Larger dimension of "a" may prevent back fillet from being formed adequately to obtain required solder strength.

※The vibration-proof capacitors of size Φ 6.3 has support terminals extending from the bottom side to the lead edge. Then, make sure to find appropriate soldering conditions to form fillet on the support terminals if required for appearance inspection

SP-Cap

Guidelines and Precaution
Mounting specifications
Packing specifications

Selection guide

Surface mount type

Catalog EOL models

POSCAP

Guidelines and Precautions
Mounting specifications
Packing specifications

Selection guide

Surface mount type

Catalog Deletion models

Catalog EOL models

OS-CON

Guidelines and Precautions
Mounting specifications
Packing specifications

Selection guide

Surface mount type

Radial lead type

Catalog EOL models

Hybrid

Guidelines and Precautions
Mounting specifications
Packing specifications

Selection guide
Line-up
Series system diagram
Products list

Surface mount type	ZA
	ZC
	ZK
	ZKU
	ZT
	ZS
	ZSU
Radial lead type	ZU
	ZE
	ZF
	ZA-A
	ZC-A
	ZK-A
	ZKU-A
ZT-A	
ZS-A	
ZSU-A	
ZE-A	
ZF-A	

Packing specifications

SP-Cap

Guidelines and Precautions
Mounting specifications
Packing specifications

Selection guide

Surface mount type

Catalog EOL models

POSCAP

Guidelines and Precautions
Mounting specifications
Packing specifications

Selection guide

Surface mount type

Catalog Deletion models

Catalog EOL models

OS-CON

Guidelines and Precautions
Mounting specifications
Packing specifications

Selection guide

Surface mount type

Radial lead type

Catalog EOL models

Hybrid

Guidelines and Precautions

Mounting specifications

Packing specifications

Line-up

Series system diagram

Products list

ZA

ZC

ZK

ZKU

ZT

ZS

ZSU

ZU

ZE

ZF

ZA-A

ZC-A

ZK-A

ZKU-A

ZT-A

ZS-A

ZSU-A

ZE-A

ZF-A

Surface mount type

Reel dimensions (not to scale)

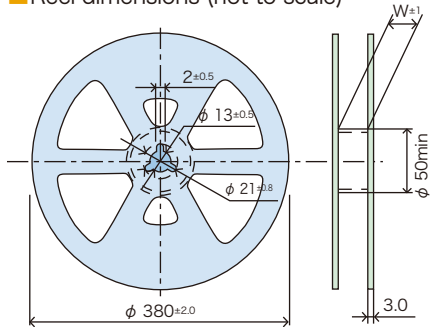

(Unit : mm)

Size code	W
C	14.0
D, D8	18.0
F, G, G12, G16	26.0

Dimensions of outer carton box

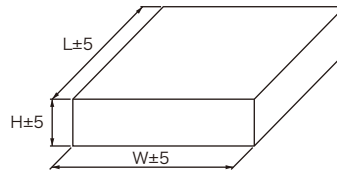

(Unit : mm)

Size code	H	W,L
C	180	395
D, D8	220	395
F, G, G12, G16	180	395

Min.packing quantity

Size code	Min.Packing Q'ty pcs.
C, D	1000
D8	900
F, G	500
G12	400
G16	250

Taping dimensions in mm

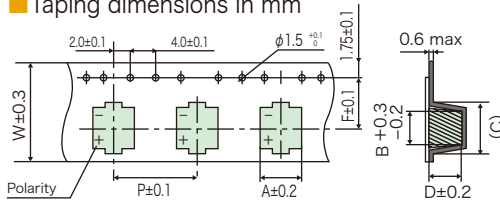

※Ask factory for technical specifications.
() Reference

(Unit : mm)

Size code	A	B	C	D	P	F	W
C	5.7	5.7	8.0	6.4	12.0	5.5	12.0
D	7.0	7.0	9.0	6.4	12.0	7.5	16.0
D8	7.0	7.0	9.0	8.4	12.0	7.5	16.0
F	8.7	8.7	12.5	11.0	16.0	11.5	24.0
G	10.7	10.7	14.5	11.0	16.0	11.5	24.0
G12	10.7	10.7	14.5	13.7	16.0	11.5	24.0
G16	10.7	10.7	14.5	17.5	20.0	11.5	24.0

Radial lead type

Taping dimensions

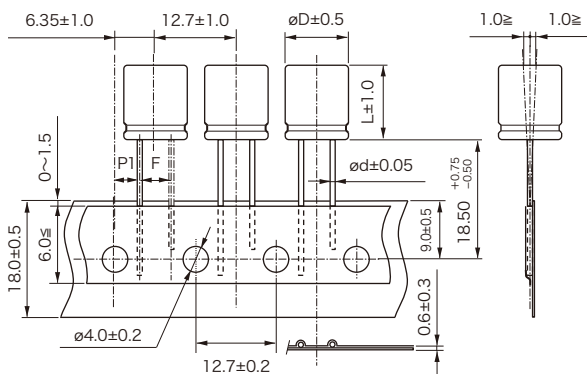

(Unit : mm)

Size code	φD	L	φd	F	P1
C	8.0	9.5	0.6	3.5±0.5	4.60±0.50
G	10.0	9.5	0.6	5.0 ^{+0.8} _{-0.2}	3.85±0.50
G12	10.0	11.7	0.8	5.0 ^{+0.8} _{-0.2}	3.85±0.50
G16	10.0	15.7	0.8	5.0 ^{+0.8} _{-0.2}	3.85±0.50

Dimensions of outer carton box / Packaging method

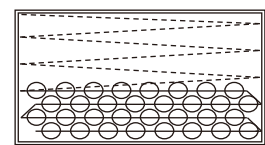
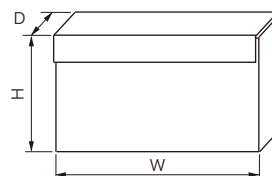

Zigzag folded

(Unit : mm)

Size code	W	H	D
F	340 max.	230 max.	55 max.
G	340 max.	170 max.	55 max.
G12	340 max.	170 max.	55 max.
G16	340 max.	170 max.	55 max.

Min.packing quantity

Size code	Min.packing quantity (pcs.)
F	1000
G	500
G12	500
G16	500

Surface mount type

Series	Page	Part No.	Features	Small size/low profile	Low ESR	For automotive	High voltage	Guaranteed at 125 °C	Category temperature range(°C)	Rated voltage (V)	ESR(mΩ)	Capacitance (μF)	Size code	Size	
														φD	L
ZA	133 to 134	EEHZA--	Low ESR High ripple current Long life 105 °C 10,000 h	●					-55 to 105	25 to 50	80 to 120	10 to 33	C	5.0	5.8
										25 to 63	50 to 120	10 to 56	D	6.3	5.8
											30 to 80	22 to 100	D8	6.3	7.7
										25 to 80	27 to 45	22 to 220	F	8.0	10.2
20 to 36	33 to 330	G	10.0	10.2											
ZC	135 to 136	EEHZC--	Low ESR High ripple current Long life 125 °C 4,000 h	●				-55 to 125	25 to 50	80 to 120	10 to 33	C	5.0	5.8	
									25 to 63	50 to 120	10 to 56	D	6.3	5.8	
										30 to 80	22 to 100	D8	6.3	7.7	
									25 to 80	27 to 45	22 to 220	F	8.0	10.2	
20 to 36	33 to 330	G	10.0	10.2											
ZK	137 to 138	EEHZK--	Large capacitance High ripple current Long life 125 °C 4,000 h	●	●	●		-55 to 125	25 to 35	80 to 100	33 to 47	C	5.0	5.8	
										50 to 60	56 to 82	D	6.3	5.8	
										30 to 35	100 to 150	D8	6.3	7.7	
										27	180 to 270	F	8.0	10.2	
										20	330 to 470	G	10.0	10.2	
ZKU	139 to 140	EEHZK-U-	Large capacitance Long life 125 °C 4,000 h	●	●	●		-55 to 125	25 to 35	80 to 100	39 to 56	C	5.0	5.8	
										50 to 60	68 to 100	D	6.3	5.8	
										30 to 35	120 to 180	D8	6.3	7.7	
										27	220 to 330	F	8.0	10.2	
										20	390 to 560	G	10.0	10.2	
ZT	141 to 142	EEHZT--	125 °C 4,000 h		●	●		-55 to 125	25 to 63	22 to 32	33 to 220	F	8.0	10.2	
										16 to 25	56 to 330	G	10.0	10.2	
ZS	143 to 144	EEHZS--	125 °C 4,000 h 135 °C 4,000 h		●	●		-55 to 135	25 to 63	14 to 19	100 to 470	G12	10.0	12.5	
										11 to 15	150 to 560	G16	10.0	16.5	
ZSU	145 to 146	EEHZS-U-	125 °C 4,000 h		●	●		-55 to 125	25 to 63	14 to 19	120 to 680	G12	10.0	12.5	
										11 to 15	180 to 1000	G16	10.0	16.5	
ZU	147 to 148	EEHZU--	125 °C 4,000 h 135 °C 4,000 h		●	●		-55 to 135	25 to 63	10 to 12	100 to 470	G12	10.0	12.5	
										8 to 10	150 to 560	G16	10.0	16.5	
ZE	149 to 150	EEHZE--	145 °C 2,000 h 135 °C 4,000 h				●	-55 to 145	25 to 63	27 to 40	33 to 220	F	8.0	10.2	
										20 to 30	56 to 330	G	10.0	10.2	
ZF	151 to 152	EEHZF--	150 °C 1,000 h				●	-55 to 150	25 to 63	27 to 40	33 to 150	F	8.0	10.2	
										20 to 30	56 to 270	G	10.0	10.2	

Radial lead type

Series	Page	Part No.	Features	Small size/low profile	Low ESR	For automotive	High voltage	Guaranteed at 125 °C	Category temperature range(°C)	Rated voltage (V)	ESR(mΩ)	Capacitance (μF)	Size code	Size	
														φD	L
ZA-A	153 to 154	EEHAZA--B	105 °C 10,000 h						-55 to 105	25 to 80	27 to 45	22 to 220	F	8.0	9.5
											20 to 36	33 to 330	G	10.0	9.5
ZC-A	155 to 156	EEHAZC--B	125 °C 4,000 h					●	-55 to 125	25 to 80	27 to 45	22 to 220	F	8.0	9.5
											20 to 36	33 to 330	G	10.0	9.5
ZK-A	157 to 158	EEHAZK--B	125 °C 4,000 h		●	●		●	-55 to 125	25 to 35	27	180 to 270	F	8.0	9.5
											20	330 to 470	G	10.0	9.5
ZKU-A	159 to 160	EEHAZK-UB	125 °C 4,000 h		●	●		●	-55 to 125	25 to 35	27	220 to 330	F	8.0	9.5
											20	390 to 560	G	10.0	9.5
ZT-A	161 to 162	EEHAZT--B	125 °C 4,000 h		●	●		●	-55 to 125	25 to 63	22 to 32	33 to 220	F	8.0	9.5
											16 to 25	56 to 330	G	10.0	9.5
ZS-A	163 to 164	EEHAZS--B	125 °C 4,000 h 135 °C 4,000 h		●	●		●	-55 to 135	25 to 63	14 to 19	100 to 470	G12	10.0	11.7
											11 to 15	150 to 560	G16	10.0	15.7
ZSU-A	165 to 166	EEHAZS-UB	125 °C 4,000 h		●	●		●	-55 to 125	25 to 63	14 to 19	120 to 680	G12	10.0	11.7
											11 to 15	180 to 1000	G16	10.0	15.7
ZE-A	167 to 168	EEHAZE--B	145 °C 2,000 h 135 °C 4,000 h				●	●	-55 to 145	25 to 63	27 to 40	33 to 220	F	8.0	9.5
											20 to 30	56 to 330	G	10.0	9.5
ZF-A	169 to 170	EEHAZF--B	150 °C 1,000 h				●	●	-55 to 150	25 to 63	27 to 40	33 to 150	F	8.0	9.5
											20 to 30	56 to 270	G	10.0	9.5

SP-Cap

Guidelines and Precaution
Mounting specifications
Packing specifications

Selection guide

Surface mount type

Catalog EOL models

POSCAP

Guidelines and Precautions
Mounting specifications
Packing specifications

Selection guide

Surface mount type

Catalog Deletion models

Catalog EOL models

OS-CON

Guidelines and Precautions
Mounting specifications
Packing specifications

Selection guide

Surface mount type

Radial lead type

Catalog EOL models

Hybrid

Guidelines and Precautions
Mounting specifications
Packing specifications

Line-up

Series system diagram

Products list

- ZA
- ZC
- ZK
- ZKU
- ZT
- ZS
- ZSU
- ZU
- ZE
- ZF
- ZA-A
- ZC-A
- ZK-A
- ZKU-A
- ZT-A
- ZS-A
- ZSU-A
- ZE-A
- ZF-A

Surface mount type

Radial lead type

Series system diagram

SP-Cap

Guidelines and Precautions
Mounting specifications
Packing specifications

Selection guide

Surface mount type

POSCAP

Guidelines and Precautions
Mounting specifications
Packing specifications

Selection guide

Surface mount type

Catalog Deletion models

Catalog EOL models

OS-CON

Guidelines and Precautions
Mounting specifications
Packing specifications

Selection guide

Surface mount type

Radial lead type

Hybrid

Guidelines and Precautions
Mounting specifications
Packing specifications

Line-up

Series system diagram

Products list

ZA	Surface mount type
ZC	Surface mount type
ZK	Surface mount type
ZKU	Surface mount type
ZT	Surface mount type
ZS	Surface mount type
ZSU	Surface mount type
ZU	Surface mount type
ZE	Surface mount type
ZF	Surface mount type
ZA-A	Radial lead type
ZC-A	Radial lead type
ZK-A	Radial lead type
ZKU-A	Radial lead type
ZT-A	Radial lead type
ZS-A	Radial lead type
ZSU-A	Radial lead type
ZE-A	Radial lead type
ZF-A	Radial lead type

Surface mount type

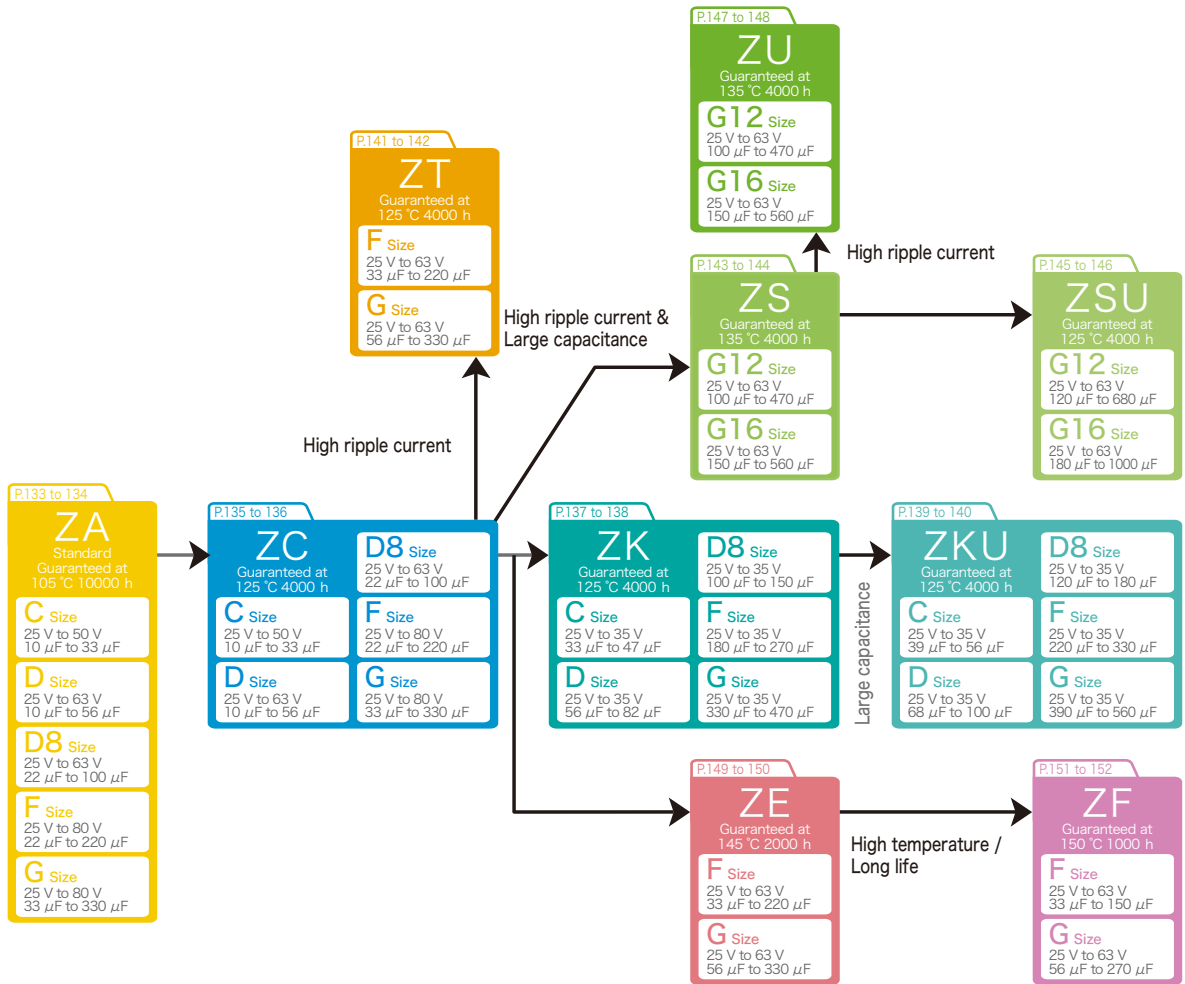

Radial lead type

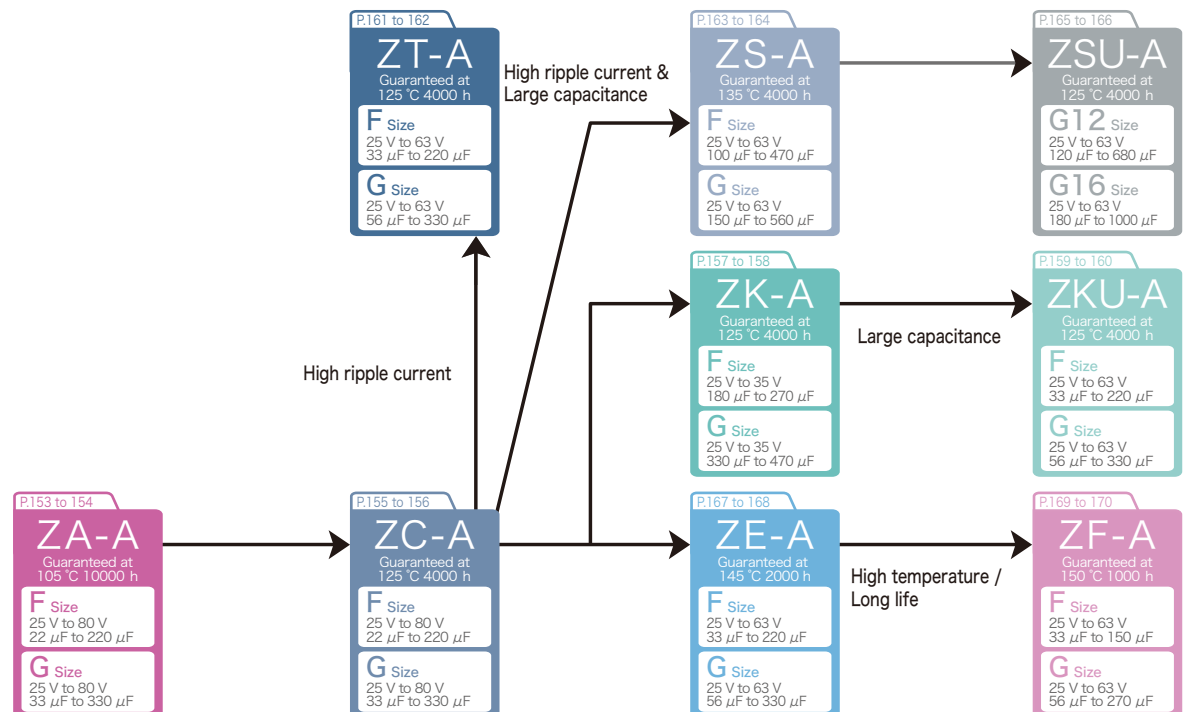

Products list

Size·ESR Matrix list / Surface mount type

Size code (ESR mΩ)

V	Series	μF																						
		10	22	27	33	39	47	56	68	82	100	120	150	180	220	270	330	390	470	560	680	1000		
25	ZA		C (80)		C (80)		D (50)	D (50)	D8 (30)		D8 (30)		F (27)		F (27)		G (20)							
	ZC		C (80)		C (80)		D (50)	D (50)	D8 (30)		D8 (30)		F (27)		F (27)		G (20)							
	ZK						C (80)		D (50)	D (50)			D8 (30)			F (27)			G (20)					
	ZKU							C (80)			D (50)			D8 (30)			F (27)			G (20)				
	ZT															F (22)		G (16)						
	ZS																			G12 (14)	G16 (11)			
	ZSU																			G12 (10)	G16 (8)		G12 (14)	G16 (11)
	ZU																							
	ZE															F (27)		G (20)						
	ZF													F (27)			G (20)							
35	ZA	C (100)	C (100)	D (60)	D (60)		D (60)			D8 (35)		F (27)		F (27)		G (20)	G (20)							
	ZC	C (100)	C (100)		D (60)		D (60)			D8 (35)		F (27)		F (27)		G (20)	G (20)							
	ZK				C (100)			D (60)			D8 (35)			F (27)			G (20)							
	ZKU					C (100)			D (60)			D8 (35)			F (27)			G (20)						
	ZT												D8 (35)		F (22)		G (16)							
	ZS																	G12 (14)			G16 (11)			
	ZSU																			G12 (14)			G16 (11)	
	ZU																			G12 (11)			G16 (9)	
	ZE													F (27)			G (20)							
	ZF												F (30)		G (23)									
50	ZA	C (120)	D (80)		D8 (40)		F (30)			F (30)		G (28)												
	ZC	C (120)	D (80)		D8 (40)		F (30)			F (30)		G (28)	G (28)											
	ZT									F (25)		G (23)	G (23)											
	ZS													G12 (17)		G16 (13)								
	ZSU														G12 (17)		G16 (13)							
	ZU													G12 (12)		G16 (10)								
	ZE										F (30)		G (28)											
	ZF										F (35)		G (28)											
	63	ZA	D (120)	D8 (80)		F (40)		F (40)	G (30)	G (30)	G (30)													
		ZC	D (120)	D8 (80)		F (40)		F (40)	G (30)	G (30)	G (30)													
ZT					F (32)		F (32)	G (25)	G (25)	G (25)														
ZS											G12 (19)		G16 (15)											
ZSU												G12 (19)		G16 (15)										
ZU											G12 (12)		G16 (10)											
ZE																								
ZF								F (40)			G (30)		G (30)											
80		ZA		F (45)		G (36)		G (36)																
		ZC		F (45)		G (36)		G (36)																

Size code (unit : mm)
 C ϕ 5.0xL5.8 CB ϕ 6.3xL7.7 G ϕ 10.0xL10.2 G16 ϕ 10.0xL16.5
 D ϕ 6.3xL5.8 F ϕ 8.0xL10.2 G12 ϕ 10.0xL12.5

SP-Cap

Guidelines and Precautions
 Mounting specifications
 Packing specifications

Selection guide

Surface mount type

Catalog EOL models

POSCAP

Guidelines and Precautions
 Mounting specifications
 Packing specifications

Selection guide

Surface mount type

Catalog Deletion models

Catalog EOL models

OS-CON

Guidelines and Precautions
 Mounting specifications
 Packing specifications

Selection guide

Size·ESR Matrix list / Radial lead type

Size code (ESR mΩ)

V	Series	μF																						
		10	22	27	33	39	47	56	68	82	100	120	150	180	220	270	330	390	470	560	680	1000		
25	ZA												F (27)		F (27)		G (20)							
	ZC												F (27)		F (27)		G (20)							
	ZK															F (27)			G (20)					
	ZKU																F (27)			G (20)				
	ZT															F (22)		G (16)						
	ZS																			G12 (14)	G16 (11)			
	ZSU																						G12 (14)	G16 (11)
	ZE															F (27)		G (20)						
	ZF																	G (20)						
	35	ZA									F (27)		F (27)			G (20)	G (20)							
ZC										F (27)		F (27)			G (20)	G (20)								
ZK													F (27)				G (20)							
ZKU														F (27)				G (20)						
ZT													F (22)			G (16)								
ZS																	G12 (14)			G16 (11)				
ZSU																				G12 (14)			G16 (11)	
ZU																								
ZE														F (27)			G (20)							
ZF															G (23)									
50	ZA						F (30)			F (30)		G (28)												
	ZC						F (30)			F (30)		G (28)	G (28)											
	ZT									F (25)		G (23)	G (23)											
	ZS													G12 (17)		G16 (13)								
	ZSU														G12 (17)		G16 (13)							
	ZU														G12 (12)		G16 (10)							
	ZE										F (30)		G (28)											
	ZF												G (28)											
	63	ZA				F (40)		F (40)	G (30)	G (30)	G (30)													
		ZC				F (40)		F (40)	G (30)	G (30)	G (30)													
ZT					F (32)		F (32)	G (25)	G (25)	G (25)														
ZS											G12 (19)		G16 (15)											
ZSU												G12 (19)		G16 (15)										
ZU																								
ZE								F (40)			G (30)		G (30)											
ZF											G (30)													
80		ZA		F (45)		G (36)		G (36)																
		ZC		F (45)		G (36)		G (36)																

Size code (unit : mm)
 F ϕ 8.0xL9.5 G ϕ 10.0xL9.5 G12 ϕ 10.0xL11.7 G16 ϕ 10.0xL15.7

Surface mount type

Radial lead type

Catalog EOL models

Hybrid

Guidelines and Precautions
 Mounting specifications
 Packing specifications

Selection guide

Series system diagram

Products list

- ZA
- ZC
- ZK
- ZKU
- ZT
- ZS
- ZSU
- ZU
- ZE
- ZF
- ZA-A
- ZC-A
- ZK-A
- ZKU-A
- ZT-A
- ZS-A
- ZSU-A
- ZE-A
- ZF-A



- Endurance: 10000 h at 105 °C
- High voltage (80 V max.)
- Vibration-proof products are available upon request. (φ6.3 mm and larger)
- Characteristics dependencies in low temperature and frequency are as small as polymer type.
- Low ESR and high ripple current (over 70% lower ESR and 100% higher ripple current than V-FP)
- AEC-Q200 compliant
- RoHS compliant

SP-Cap

Specifications

Items	Specifications				
Size code	C	D	D8	F	G
Category temperature range	-55 °C to +105 °C				
Rated voltage range	25 V to 50 V	25 V to 63 V		25 V to 80 V	
Nominal capacitance range	10 μF to 33 μF	10 μF to 56 μF	22 μF to 100 μF	22 μF to 220 μF	33 μF to 330 μF
Capacitance tolerance	±20 % (120 Hz/+20 °C)				
Leakage current	$I \leq 0.01 CV (\mu A)$, 2 minutes after reaching rated voltage, 20 °C *CV = (Capacitance in μF) x (Rated voltage in V)				
Dissipation factor(tanδ)	Please see the attached characteristics list				
Surge voltage(V)	Rated voltage × 1.25 (15 °C to 35 °C)				
Endurance	+105 °C, 10000 h, apply the rated ripple current without exceeding the rated voltage				
	Capacitance change	Within ±30 % of the initial value			
	tan δ	≤ 200 % of the initial limit			
	E.S.R.	≤ 200 % of the initial limit			
	Leakage current	Within the initial limit			
ESR after endurance (Ω/100 kHz) (-40 °C)	Size code				
	C	D	D8	F	G
	2.0	1.4	0.8	0.4	0.3
Shelf life	After storage for 1000 hours at +105 °C±2 °C with no voltage applied and then being stabilized at +20 °C, capacitors shall meet the limits specified in endurance. (With voltage treatment)				
Damp heat (Load)	+85 °C, 85 % to 90 % RH, 2000 h, rated voltage applied				
	Capacitance change	Within ±30 % of the initial value			
	tan δ	≤ 200 % of the initial limit			
	E.S.R.	≤ 200 % of the initial limit			
Resistance to soldering heat	After reflow soldering and then being stabilized at +20 °C, capacitors shall meet the following limits.				
	Capacitance change	Within ±10 % of the initial value			
	tanδ	Within the initial limit			
	Leakage current	Within the initial limit			

Marking and Dimensions

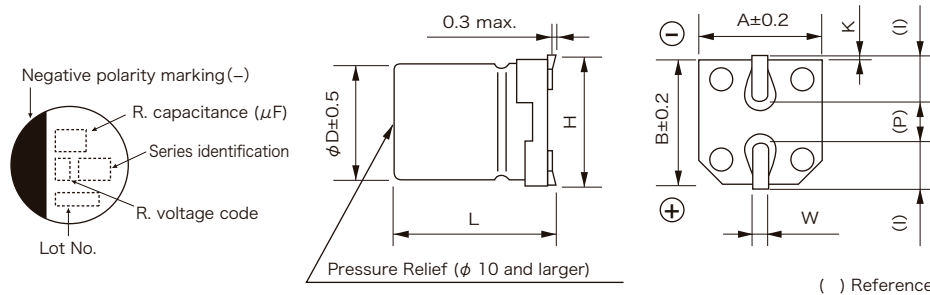

(Unit : mm)

R. voltage (V)	25	35	50	63	80
Code	E	V	H	J	K

Size code	φD	L	A,B	H	I	W	P	K
C	5.0	5.8±0.3	5.3	6.5 max.	2.2	0.65±0.1	1.5	0.35 ^{+0.15} _{-0.20}
D	6.3	5.8±0.3	6.6	7.8 max.	2.6	0.65±0.1	1.8	0.35 ^{+0.15} _{-0.20}
D8	6.3	7.7±0.3	6.6	7.8 max.	2.6	0.65±0.1	1.8	0.35 ^{+0.15} _{-0.20}
F	8.0	10.2±0.3	8.3	10.0 max.	3.4	0.90±0.2	3.1	0.70±0.2
G	10.0	10.2±0.3	10.3	12.0 max.	3.5	0.90±0.2	4.6	0.70±0.2

※The dimensions of the vibration-proof products, please refer to the page of the mounting specification

Hybrid

Guidelines and Precautions
Mounting specifications
Packing specifications

Line-up
Series system diagram

- Products list
- ZA
 - ZC
 - ZK
 - ZKU
 - ZT
 - ZS
 - ZSU
 - ZU
 - ZE
 - ZF
 - ZA-A
 - ZC-A
 - ZK-A
 - ZKU-A
 - ZT-A
 - ZS-A
 - ZSU-A
 - ZE-A
 - ZF-A

Surface mount type
Radial lead type

Characteristics list

Endurance : 105 °C 10000 h

Series	Rated voltage (V)	Capacitance (±20 %) (μF)	Case size (mm)			Size code	Specifications			Part number		Min. Packaging Qty (pcs)	
			φD	L			Ripple Current ※1 (mA rms)	ESR ※2 (mΩ)	tan δ ※3	Standard product	Vibration-proof product		Taping
				Standard product	Vibration-proof product								
ZA	25	22	5.0	5.8	-	C	900	80	0.14	EEHZA1E220R	-	1000	
		33	5.0	5.8	-		900	80	0.14	EEHZA1E330R	-	1000	
		47	6.3	5.8	6.1		D	1300	50	0.14	EEHZA1E470P	EEHZA1E470V	1000
		56	6.3	5.8	6.1	1300		50	0.14	EEHZA1E560P	EEHZA1E560V	1000	
		68	6.3	7.7	8.0	D8	2000	30	0.14	EEHZA1E680XP	EEHZA1E680XV	900	
		100	6.3	7.7	8.0		2000	30	0.14	EEHZA1E101XP	EEHZA1E101XV	900	
		150	8.0	10.2	10.5	F	2300	27	0.14	EEHZA1E151P	EEHZA1E151V	500	
		220	8.0	10.2	10.5		2300	27	0.14	EEHZA1E221P	EEHZA1E221V	500	
		330	10.0	10.2	10.5	G	2500	20	0.14	EEHZA1E331P	EEHZA1E331V	500	
	35	10	5.0	5.8	-	C	900	100	0.12	EEHZA1V100R	-	1000	
		22	5.0	5.8	-		900	100	0.12	EEHZA1V220R	-	1000	
		27	6.3	5.8	6.1	D	1300	60	0.12	EEHZA1V270P	EEHZA1V270V	1000	
		33	6.3	5.8	6.1		1300	60	0.12	EEHZA1V330P	EEHZA1V330V	1000	
		47	6.3	5.8	6.1	D8	1300	60	0.12	EEHZA1V470P	EEHZA1V470V	1000	
		68	6.3	7.7	8.0		2000	35	0.12	EEHZA1V680XP	EEHZA1V680XV	900	
		100	8.0	10.2	10.5	F	2300	27	0.12	EEHZA1V101P	EEHZA1V101V	500	
		150	8.0	10.2	10.5		2300	27	0.12	EEHZA1V151P	EEHZA1V151V	500	
		220	10.0	10.2	10.5	G	2500	20	0.12	EEHZA1V221P	EEHZA1V221V	500	
	270	10.0	10.2	10.5	2500		20	0.12	EEHZA1V271P	EEHZA1V271V	500		
	50	10	5.0	5.8	-	C	750	120	0.10	EEHZA1H100R	-	1000	
		22	6.3	5.8	6.1	D	1100	80	0.10	EEHZA1H220P	EEHZA1H220V	1000	
		33	6.3	7.7	8.0	D8	1600	40	0.10	EEHZA1H330XP	EEHZA1H330XV	900	
		47	8.0	10.2	10.5		1800	30	0.10	EEHZA1H470P	EEHZA1H470V	500	
		68	8.0	10.2	10.5	F	1800	30	0.10	EEHZA1H680P	EEHZA1H680V	500	
		100	10.0	10.2	10.5		G	2000	28	0.10	EEHZA1H101P	EEHZA1H101V	500
	63	10	6.3	5.8	6.1	D	1000	120	0.08	EEHZA1J100P	EEHZA1J100V	1000	
		22	6.3	7.7	8.0	D8	1500	80	0.08	EEHZA1J220XP	EEHZA1J220XV	900	
		33	8.0	10.2	10.5		1700	40	0.08	EEHZA1J330P	EEHZA1J330V	500	
		47	8.0	10.2	10.5	F	1700	40	0.08	EEHZA1J470P	EEHZA1J470V	500	
		56	10.0	10.2	10.5		1800	30	0.08	EEHZA1J560P	EEHZA1J560V	500	
		68	10.0	10.2	10.5	G	1800	30	0.08	EEHZA1J680P	EEHZA1J680V	500	
		82	10.0	10.2	10.5		1800	30	0.08	EEHZA1J820P	EEHZA1J820V	500	
	80	22	8.0	10.2	10.5	F	1550	45	0.08	EEHZA1K220P	EEHZA1K220V	500	
		33	10.0	10.2	10.5	G	1700	36	0.08	EEHZA1K330P	EEHZA1K330V	500	
		47	10.0	10.2	10.5		1700	36	0.08	EEHZA1K470P	EEHZA1K470V	500	

※1: Ripple current (100 kHz/ +105 °C) ※2: ESR (100 kHz/+20 °C) ※3: tan δ (120 Hz/ +20 °C)
 ◆Please refer to the P127 to 129 in this catalog for "Reflow conditions" and "Taping specifications".

Frequency correction factor for ripple current

Rated capacitance(μF)	Frequency	100 Hz ≤ f < 200 Hz	200 Hz ≤ f < 300 Hz	300 Hz ≤ f < 500 Hz	500 Hz ≤ f < 1 kHz
C < 47 μF	Correction factor	0.10	0.10	0.15	0.20
47 μF ≤ C < 150 μF		0.15	0.20	0.25	0.30
150 μF ≤ C		0.15	0.25	0.25	0.30
Rated capacitance(μF)	Frequency	1 kHz ≤ f < 2 kHz	2 kHz ≤ f < 3 kHz	3 kHz ≤ f < 5 kHz	5 kHz ≤ f < 10 kHz
C < 47 μF	Correction factor	0.30	0.40	0.45	0.50
47 μF ≤ C < 150 μF		0.40	0.45	0.55	0.60
150 μF ≤ C		0.45	0.50	0.60	0.65
Rated capacitance(μF)	Frequency	10 kHz ≤ f < 15 kHz	15 kHz ≤ f < 20 kHz	20 kHz ≤ f < 30 kHz	30 kHz ≤ f < 40 kHz
C < 47 μF	Correction factor	0.60	0.65	0.70	0.75
47 μF ≤ C < 150 μF		0.70	0.75	0.80	0.80
150 μF ≤ C		0.75	0.80	0.85	0.85
Rated capacitance(μF)	Frequency	40 kHz ≤ f < 50 kHz	50 kHz ≤ f < 100 kHz	100 kHz ≤ f < 500 kHz	500 kHz ≤ f
C < 47 μF	Correction factor	0.80	0.85	1.00	1.05
47 μF ≤ C < 150 μF		0.85	0.90	1.00	1.00
150 μF ≤ C		0.85	0.90	1.00	1.00

Design and specifications are each subject to change without notice. Ask factory for the current technical specifications before purchase and/or use.
 Should a safety concern arise regarding this product, please be sure to contact us immediately.

SP-Cap

Guidelines and Precautions
 Mounting specifications
 Packing specifications

Selection guide

Surface mount type

Catalog EOL models

POSCAP

Guidelines and Precautions
 Mounting specifications
 Packing specifications

Selection guide

Surface mount type

Catalog Deletion models

Catalog EOL models

OS-CON

Guidelines and Precautions
 Mounting specifications
 Packing specifications

Selection guide

Surface mount type

Radial lead type

Catalog EOL models

Hybrid

Guidelines and Precautions
 Mounting specifications
 Packing specifications

Selection guide

Series system diagram

Products list

Surface mount type	ZA
	ZC
	ZK
	ZKU
	ZT
	ZS
	ZSU
ZU	
ZE	
ZF	
Radial lead type	ZA-A
	ZC-A
	ZK-A
	ZKU-A
	ZT-A
	ZS-A
	ZSU-A
ZE-A	
ZF-A	



- Endurance: 4000 h at 125 °C
- High-withstand voltage (80 V max.)
- Low ESR and high ripple current (over 85% lower ESR than V-TP)
- Vibration-proof products are available upon request. (φ6.3 mm and larger)
- Characteristics dependencies in low temperature and frequency are as small as polymer type.
- AEC-Q200 compliant
- RoHS compliant

SP-Cap

Guidelines and Precautions
Mounting specifications
Packing specifications

Selection guide

Surface mount type

Catalog EOL models

POSCAP

Guidelines and Precautions
Mounting specifications
Packing specifications

Selection guide

Surface mount type

Catalog Deletion models

Catalog EOL models

OS-CON

Guidelines and Precautions
Mounting specifications
Packing specifications

Selection guide

Surface mount type

Radial lead type

Catalog EOL models

Hybrid

Guidelines and Precautions
Mounting specifications
Packing specifications

Line-up

Series system diagram

Products list

- ZA
- ZC
- ZK
- ZKU
- ZT
- ZS
- ZSU
- ZU
- ZE
- ZF
- ZA-A
- ZC-A
- ZK-A
- ZKU-A
- ZT-A
- ZS-A
- ZSU-A
- ZE-A
- ZF-A

Specifications

Items	Specifications				
	C	D	D8	F	G
Size code	C	D	D8	F	G
Category temperature range	-55 °C to +125 °C				
Rated voltage range	25 V to 50 V	25 V to 63 V		25 V to 80 V	
Nominal capacitance range	10 μF to 33 μF	10 μF to 56 μF	22 μF to 100 μF	22 μF to 220 μF	33 μF to 330 μF
Capacitance tolerance	±20 % (120 Hz/+20 °C)				
Leakage current	I ≤ 0.01 CV (μA), 2 minutes after reaching rated voltage, 20 °C *CV = (Capacitance in μF) x (Rated voltage in V)				
Dissipation factor(tanδ)	Please see the attached characteristics list				
Surge voltage(V)	Rated voltage × 1.25 (15 °C to 35 °C)				
Endurance 1	+125 °C, 4000 h, apply the rated ripple current without exceeding the rated voltage				
	Capacitance change	Within ±30 % of the initial value			
	tan δ	≤ 200 % of the initial limit			
	E.S.R.	≤ 200 % of the initial limit			
Endurance 2	+125 °C, 3000 h, apply the rated ripple current without exceeding the rated voltage				
	Capacitance change	Within ±30 % of the initial value			
	tan δ	≤ 200 % of the initial limit			
	E.S.R.	≤ 300 % of the initial limit			
Shelf life	After storage for 1000 hours at +125 °C±2 °C with no voltage applied and then being stabilized at +20 °C, capacitors shall meet the limits specified in endurance. (With voltage treatment)				
	+85 °C, 85 % to 90 % RH, 2000 h, rated voltage applied				
Damp heat (Load)	Capacitance change	Within ±30 % of the initial value			
	tan δ	≤ 200 % of the initial limit			
	E.S.R.	≤ 200 % of the initial limit			
	Leakage current	Within the initial limit			
Resistance to soldering heat	After reflow soldering and then being stabilized at +20 °C, capacitors shall meet the following limits.				
	Capacitance change	Within ±10 % of the initial value			
	tan δ	Within the initial limit			
	Leakage current	Within the initial limit			

Marking and Dimensions

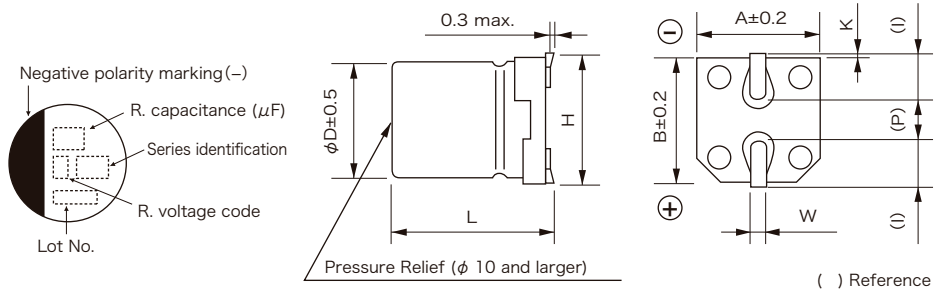

(Unit : mm)

R. voltage (V)	25	35	50	63	80
Code	E	V	H	J	K

Size code	φD	L	A,B	H	I	W	P	K
C	5.0	5.8±0.3	5.3	6.5 max.	2.2	0.65±0.1	1.5	0.35 ^{+0.15} _{-0.20}
D	6.3	5.8±0.3	6.6	7.8 max.	2.6	0.65±0.1	1.8	0.35 ^{+0.15} _{-0.20}
D8	6.3	7.7±0.3	6.6	7.8 max.	2.6	0.65±0.1	1.8	0.35 ^{+0.15} _{-0.20}
F	8.0	10.2±0.3	8.3	10.0 max.	3.4	0.90±0.2	3.1	0.70±0.2
G	10.0	10.2±0.3	10.3	12.0 max.	3.5	0.90±0.2	4.6	0.70±0.2

※The dimensions of the vibration-proof products, please refer to the page of the mounting specification

Characteristics list

Endurance 1: 125 °C 4000 hours
Endurance 2: 125 °C 3000 hours

Series	Rated voltage (V)	Capacitance (+20%) (μF)	Case size (mm)			Size code	Specifications				Part number		Min. Packaging Qty (pcs)	
			φD	L			Ripple Current ※1 (mA rms)		ESR ※2 (mΩ)	tan δ ※3	Standard product	Vibration-proof product		Taping
				Standard product	Vibration-proof product		Endurance 1	Endurance 2						
ZC	25	22	5.0	5.8	—	C	550	—	80	0.14	EEHZC1E220R	—	1000	
		33	5.0	5.8	—		D	550	—	80	0.14	EEHZC1E330R	—	1000
		47	6.3	5.8	6.1			900	—	50	0.14	EEHZC1E470P	EEHZC1E470V	1000
		56	6.3	5.8	6.1	D8	900	—	50	0.14	EEHZC1E560P	EEHZC1E560V	1000	
		68	6.3	7.7	8.0		1400	—	30	0.14	EEHZC1E680XP	EEHZC1E680XV	900	
		100	6.3	7.7	8.0		1400	—	30	0.14	EEHZC1E101XP	EEHZC1E101XV	900	
		150	8.0	10.2	10.5	F	1600	1900	27	0.14	EEHZC1E151P	EEHZC1E151V	500	
		220	8.0	10.2	10.5		1600	1900	27	0.14	EEHZC1E221P	EEHZC1E221V	500	
		330	10.0	10.2	10.5		2000	2900	20	0.14	EEHZC1E331P	EEHZC1E331V	500	
	35	10	5.0	5.8	—	C	550	—	100	0.12	EEHZC1V100R	—	1000	
		22	5.0	5.8	—		550	—	100	0.12	EEHZC1V220R	—	1000	
		33	6.3	5.8	6.1	D	900	—	60	0.12	EEHZC1V330P	EEHZC1V330V	1000	
		47	6.3	5.8	6.1		900	—	60	0.12	EEHZC1V470P	EEHZC1V470V	1000	
		68	6.3	7.7	8.0	D8	1400	—	35	0.12	EEHZC1V680XP	EEHZC1V680XV	900	
		100	8.0	10.2	10.5		F	1600	1900	27	0.12	EEHZC1V101P	EEHZC1V101V	500
		150	8.0	10.2	10.5			1600	1900	27	0.12	EEHZC1V151P	EEHZC1V151V	500
		220	10.0	10.2	10.5	G	2000	2800	20	0.12	EEHZC1V221P	EEHZC1V221V	500	
		270	10.0	10.2	10.5		2000	2800	20	0.12	EEHZC1V271P	EEHZC1V271V	500	
	50	10	5.0	5.8	—	C	500	—	120	0.10	EEHZC1H100R	—	1000	
		22	6.3	5.8	6.1	D	750	—	80	0.10	EEHZC1H220P	EEHZC1H220V	1000	
		33	6.3	7.7	8.0	D8	1100	—	40	0.10	EEHZC1H330XP	EEHZC1H330XV	900	
		47	8.0	10.2	10.5		1250	—	30	0.10	EEHZC1H470P	EEHZC1H470V	500	
		68	8.0	10.2	10.5	F	1250	—	30	0.10	EEHZC1H680P	EEHZC1H680V	500	
		100	10.0	10.2	10.5		1600	—	28	0.10	EEHZC1H101P	EEHZC1H101V	500	
		120	10.0	10.2	10.5	G	1600	—	28	0.10	EEHZC1H121P	EEHZC1H121V	500	
	63	10	6.3	5.8	6.1	D	700	—	120	0.08	EEHZC1J100P	EEHZC1J100V	1000	
		22	6.3	7.7	8.0	D8	900	—	80	0.08	EEHZC1J220XP	EEHZC1J220XV	900	
		33	8.0	10.2	10.5		F	1100	—	40	0.08	EEHZC1J330P	EEHZC1J330V	500
		47	8.0	10.2	10.5	1100		—	40	0.08	EEHZC1J470P	EEHZC1J470V	500	
		56	10.0	10.2	10.5	1400		—	30	0.08	EEHZC1J560P	EEHZC1J560V	500	
		68	10.0	10.2	10.5	G	1400	—	30	0.08	EEHZC1J680P	EEHZC1J680V	500	
		82	10.0	10.2	10.5		1400	—	30	0.08	EEHZC1J820P	EEHZC1J820V	500	
	80	22	8.0	10.2	10.5	F	1050	—	45	0.08	EEHZC1K220P	EEHZC1K220V	500	
		33	10.0	10.2	10.5	G	1360	—	36	0.08	EEHZC1K330P	EEHZC1K330V	500	
		47	10.0	10.2	10.5		1360	—	36	0.08	EEHZC1K470P	EEHZC1K470V	500	

※1: Ripple current (100 kHz/ +125 °C) ※2: ESR (100 kHz/+20 °C) ※3: tan δ (120 Hz/ +20 °C)
◆Please refer to the P127 to 129 in this catalog for "Reflow conditions" and "Taping specifications".

Frequency correction factor for ripple current

Rated capacitance(μF)	Frequency	100 Hz ≤ f < 200 Hz	200 Hz ≤ f < 300 Hz	300 Hz ≤ f < 500 Hz	500 Hz ≤ f < 1 kHz
C < 47 μF	Correction factor	0.10	0.10	0.15	0.20
47 μF ≤ C < 150 μF		0.15	0.20	0.25	0.30
150 μF ≤ C		0.15	0.25	0.25	0.30

Rated capacitance(μF)	Frequency	1 kHz ≤ f < 2 kHz	2 kHz ≤ f < 3 kHz	3 kHz ≤ f < 5 kHz	5 kHz ≤ f < 10 kHz
C < 47 μF	Correction factor	0.30	0.40	0.45	0.50
47 μF ≤ C < 150 μF		0.40	0.45	0.55	0.60
150 μF ≤ C		0.45	0.50	0.60	0.65

Rated capacitance(μF)	Frequency	10 kHz ≤ f < 15 kHz	15 kHz ≤ f < 20 kHz	20 kHz ≤ f < 30 kHz	30 kHz ≤ f < 40 kHz
C < 47 μF	Correction factor	0.60	0.65	0.70	0.75
47 μF ≤ C < 150 μF		0.70	0.75	0.80	0.80
150 μF ≤ C		0.75	0.80	0.85	0.85

Rated capacitance(μF)	Frequency	40 kHz ≤ f < 50 kHz	50 kHz ≤ f < 100 kHz	100 kHz ≤ f < 500 kHz	500 kHz ≤ f
C < 47 μF	Correction factor	0.80	0.85	1.00	1.05
47 μF ≤ C < 150 μF		0.85	0.90	1.00	1.00
150 μF ≤ C		0.85	0.90	1.00	1.00

After endurance ESR(100 kHz, -40 °C)

Size code	C	D	D8	F	G
ESR(Ω)	2.0	1.4	0.8	0.4	0.3

Design and specifications are each subject to change without notice. Ask factory for the current technical specifications before purchase and/or use.
Should a safety concern arise regarding this product, please be sure to contact us immediately.

SP-Cap

Guidelines and Precautions
Mounting specifications
Packaging specifications

Selection guide

Surface mount type

Catalog EOL models

POSCAP

Guidelines and Precautions
Mounting specifications
Packaging specifications

Selection guide

Surface mount type

Catalog Deletion models

Catalog EOL models

OS-CON

Guidelines and Precautions
Mounting specifications
Packaging specifications

Selection guide

Surface mount type

Radial lead type

Catalog EOL models

Hybrid

Guidelines and Precautions
Mounting specifications
Packaging specifications

Line-up
Series system diagram
Products list

Surface mount type	ZC
	ZA
	ZK
	ZKU
	ZT
	ZS
	ZSU
	ZU
	ZE
	ZF
	ZA-A
	ZC-A
	ZK-A
	ZKU-A
ZT-A	
ZS-A	
ZSU-A	
ZE-A	
ZF-A	

Radial lead type



- High capacitance and High ripple current compared with ZC series
- Characteristics dependencies in low temperature and frequency are as small as polymer type.
- Endurance : 4000 h at 125 °C (High temperature / Long life)
- Vibration-proof products are available upon request. (φ6.3 mm and larger)
- Low ESR (over 85% lower ESR than V-TP)
- AEC-Q200 compliant
- RoHS compliant

SP-Cap

Specifications

Items	Specifications				
	C	D	D8	F	G
Size code	C	D	D8	F	G
Category temperature range	-55 °C to +125 °C				
Rated voltage range	25 V to 35 V				
Nominal capacitance range	33 μF to 47 μF	56 μF to 82 μF	100 μF to 150 μF	180 μF to 270 μF	330 μF to 470 μF
Capacitance tolerance	±20 % (120 Hz/+20 °C)				
Leakage current	$I \leq 0.01 CV (\mu A)$, 2 minutes after reaching rated voltage, 20 °C *CV = (Capacitance in μF) x (Rated voltage in V)				
Dissipation factor (tan δ)	Please see the attached characteristics list				
Surge voltage (V)	Rated voltage × 1.25 (15 °C to 35 °C)				
Endurance	+125 °C, 4000 h, apply the rated ripple current without exceeding the rated voltage				
	Capacitance change	Within ±30 % of the initial value			
	tan δ	≤ 200 % of the initial limit			
	E.S.R.	≤ 200 % of the initial limit			
	Leakage current	Within the initial limit			
	ESR after endurance (Ω/100 kHz) (-40 °C)	Size code			
Shelf life	After storage for 1000 hours at +125 °C±2 °C with no voltage applied and then being stabilized at +20 °C, capacitors shall meet the limits specified in endurance. (With voltage treatment)				
	85 °C, 85 % to 90 % RH, 2000 h, rated voltage applied				
Damp heat (Load)	Capacitance change	Within ±30 % of the initial value			
	tan δ	≤ 200 % of the initial limit			
	E.S.R.	≤ 200 % of the initial limit			
	Leakage current	Within the initial limit			
Resistance to soldering heat	After reflow soldering and then being stabilized at +20 °C, capacitors shall meet the following limits.				
	Capacitance change	Within ±10 % of the initial value			
	tan δ	Within the initial limit			
	Leakage current	Within the initial limit			

Marking and Dimensions

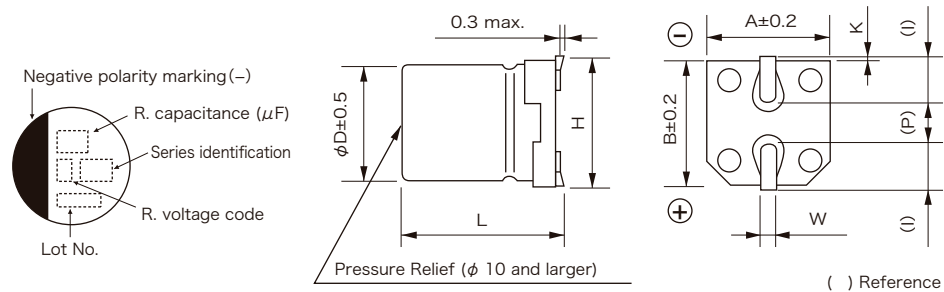

R. voltage (V)	25	35
Code	E	V

(Unit : mm)

Size code	φD	L	A,B	H	I	W	P	K
C	5.0	5.8±0.3	5.3	6.5 max.	2.2	0.65±0.1	1.5	0.35 ^{+0.15} _{-0.20}
D	6.3	5.8±0.3	6.6	7.8 max.	2.6	0.65±0.1	1.8	0.35 ^{+0.15} _{-0.20}
D8	6.3	7.7±0.3	6.6	7.8 max.	2.6	0.65±0.1	1.8	0.35 ^{+0.15} _{-0.20}
F	8.0	10.2±0.3	8.3	10.0 max.	3.4	0.90±0.2	3.1	0.70±0.2
G	10.0	10.2±0.3	10.3	12.0 max.	3.5	0.90±0.2	4.6	0.70±0.2

※The dimensions of the vibration-proof products, please refer to the page of the mounting specification

Guidelines and Precautions
Mounting specifications
Packing specifications

Selection guide

Surface mount type

Catalog EOL models

Guidelines and Precautions
Mounting specifications
Packing specifications

Selection guide

Surface mount type

Catalog Deletion models
Catalog EOL models

Guidelines and Precautions
Mounting specifications
Packing specifications

Selection guide

Radial lead type

Catalog EOL models

Hybrid

- Guidelines and Precautions
Mounting specifications
Packing specifications
- Line-up
Series system diagram
Products list
- ZA
 - ZC
 - ZK**
 - ZKU
 - ZT
 - ZS
 - ZSU
 - ZU
 - ZE
 - ZF
 - ZA-A
 - ZC-A
 - ZK-A
 - ZKU-A
 - ZT-A
 - ZS-A
 - ZSU-A
 - ZE-A
 - ZF-A
- Surface mount type
- Radial lead type

Characteristics list

Endurance : 125 °C 4000 h

Series	Rated voltage (V)	Capacitance (±20 %) (μF)	Case size (mm)			Size code	Specifications			Part number		Min. Packaging Qty (pcs)
			φD	L			Ripple Current ※1 (mA rms)	ESR ※2 (mΩ)	tan δ ※3	Standard product	Vibration-proof product	
				Standard product	Vibration-proof product							
ZK	25	47	5.0	5.8	-	C	850	80	0.14	EEHZK1E470R	-	1000
		68	6.3	5.8	6.1	D	1300	50	0.14	EEHZK1E680P	EEHZK1E680V	1000
		82	6.3	5.8	6.1	D	1300	50	0.14	EEHZK1E820P	EEHZK1E820V	1000
		150	6.3	7.7	8.0	D8	1800	30	0.14	EEHZK1E151XP	EEHZK1E151XV	900
		270	8.0	10.2	10.5	F	2000	27	0.14	EEHZK1E271P	EEHZK1E271V	500
		470	10.0	10.2	10.5	G	2800	20	0.14	EEHZK1E471P	EEHZK1E471V	500
	35	33	5.0	5.8	-	C	750	100	0.12	EEHZK1V330R	-	1000
		56	6.3	5.8	6.1	D	1200	60	0.12	EEHZK1V560P	EEHZK1V560V	1000
		100	6.3	7.7	8.0	D8	1700	35	0.12	EEHZK1V101XP	EEHZK1V101XV	900
		180	8.0	10.2	10.5	F	2000	27	0.12	EEHZK1V181P	EEHZK1V181V	500
330		10.0	10.2	10.5	G	2800	20	0.12	EEHZK1V331P	EEHZK1V331V	500	

※1: Ripple current (100 kHz/ +125 °C)

※2: ESR (100 kHz/+20 °C)

※3: tan δ (120 Hz/ +20 °C)

◆Please refer to the P127 to 129 in this catalog for "Reflow conditions" and "Taping specifications".

Frequency correction factor for ripple current

Rated capacitance(μF)	Frequency	100 Hz ≤ f < 200 Hz	200 Hz ≤ f < 300 Hz	300 Hz ≤ f < 500 Hz	500 Hz ≤ f < 1 kHz
C < 47 μF	Correction factor	0.15	0.20	0.25	0.35
47 μF ≤ C < 100 μF		0.15	0.25	0.30	0.40
100 μF ≤ C		0.15	0.25	0.30	0.40

Rated capacitance(μF)	Frequency	1 kHz ≤ f < 2 kHz	2 kHz ≤ f < 3 kHz	3 kHz ≤ f < 5 kHz	5 kHz ≤ f < 10 kHz
C < 47 μF	Correction factor	0.45	0.55	0.60	0.65
47 μF ≤ C < 100 μF		0.50	0.60	0.65	0.70
100 μF ≤ C		0.50	0.60	0.65	0.70

Rated capacitance(μF)	Frequency	10 kHz ≤ f < 15 kHz	15 kHz ≤ f < 20 kHz	20 kHz ≤ f < 30 kHz	30 kHz ≤ f < 40 kHz
C < 47 μF	Correction factor	0.70	0.75	0.75	0.75
47 μF ≤ C < 100 μF		0.75	0.75	0.80	0.80
100 μF ≤ C		0.75	0.80	0.85	0.85

Rated capacitance(μF)	Frequency	40 kHz ≤ f < 50 kHz	50 kHz ≤ f < 100 kHz	100 kHz ≤ f < 500 kHz	500 kHz ≤ f
C < 47 μF	Correction factor	0.80	0.85	1.00	1.05
47 μF ≤ C < 100 μF		0.85	0.90	1.00	1.00
100 μF ≤ C		0.85	0.90	1.00	1.00

Design and Specifications are each subject to change without notice. Ask factory for the current technical Specifications before purchase and/or use.

Should a safety concern arise regarding this product, please be sure to contact us immediately.

SP-Cap

Guidelines and Precautions
Mounting specifications
Packaging specifications

Selection guide

Surface mount type

Catalog EOL models

POSCAP

Guidelines and Precautions
Mounting specifications
Packaging specifications

Selection guide

Surface mount type

Catalog Deletion models

Catalog EOL models

OS-CON

Guidelines and Precautions
Mounting specifications
Packaging specifications

Selection guide

Surface mount type

Radial lead type

Catalog EOL models

Hybrid

Guidelines and Precautions
Mounting specifications
Packaging specifications

Line-up

Series system diagram

Products list

ZA

ZC

ZK

ZKU

ZT

ZS

ZSU

ZU

ZE

ZF

ZA-A

ZC-A

ZK-A

ZKU-A

ZT-A

ZS-A

ZSU-A

ZE-A

ZF-A

Design and specifications are each subject to change without notice. Ask factory for the current technical specifications before purchase and/or use.

Should a safety concern arise regarding this product, please be sure to contact us immediately.



- Endurance : 4000 h at 125 °C (High temperature / Long life)
- Large capacitance compared with ZK series
- Low ESR (over 85% lower ESR than V-TP)
- Vibration-proof products are available upon request. (φ6.3 mm and larger)
- Characteristics dependencies in low temperature and frequency are as small as polymer type.
- AEC-Q200 compliant
- RoHS compliant

SP-Cap

Guidelines and Precautions
Mounting specifications
Packing specifications

Selection guide

Surface mount type

Catalog EOL models

POSCAP

Guidelines and Precautions
Mounting specifications
Packing specifications

Selection guide

Surface mount type

Catalog Deletion models

Catalog EOL models

OS-CON

Guidelines and Precautions
Mounting specifications
Packing specifications

Selection guide

Surface mount type

Radial lead type

Catalog EOL models

Hybrid

Guidelines and Precautions

Mounting specifications

Packing specifications

Line-up

Series system diagram

Products list

Selection guide

ZKU

ZT

ZS

ZSU

ZU

ZE

ZF

ZA-A

ZC-A

ZK-A

ZKU-A

ZT-A

ZS-A

ZSU-A

ZE-A

ZF-A

Specifications

Items	Specifications				
	C	D	D8	F	G
Size code	C	D	D8	F	G
Category temperature range	-55 °C to +125 °C				
Rated voltage range	25 V to 35 V				
Nominal capacitance range	39 μF to 56 μF	68 μF to 100 μF	120 μF to 180 μF	220 μF to 330 μF	390 μF to 560 μF
Capacitance tolerance	±20 % (120 Hz/+20 °C)				
Leakage current	I ≤ 0.01 CV (μA), 2 minutes after reaching rated voltage, 20 °C *CV = (Capacitance in μF) x (Rated voltage in V)				
Dissipation factor (tan δ)	Please see the attached characteristics list				
Surge voltage (V)	Rated voltage x 1.25 (15 °C to 35 °C)				
Endurance	+125 °C±2 °C, 4000 h, apply the rated ripple current without exceeding the rated voltage.				
	Capacitance change	Within ±30 % of the initial value			
	tan δ	≤ 200 % of the initial limit			
	E.S.R.	≤ 200 % of the initial limit			
	Leakage current	Within the initial limit			
	ESR after endurance (Ω/100 kHz) (-40 °C)	Size code			
Shelf life	After storage for 1000 hours at +125 °C±2 °C with no voltage applied and then being stabilized at +20 °C, capacitors shall meet the limits specified in endurance. (With voltage treatment)				
	85 °C, 85 % to 90 % RH, 2000 h, rated voltage applied				
Damp heat (Load)	Capacitance change	Within ±30 % of the initial value			
	tan δ	≤ 200 % of the initial limit			
	E.S.R.	≤ 200 % of the initial limit			
	Leakage current	Within the initial limit			
Resistance to soldering heat	After reflow soldering and then being stabilized at +20 °C, capacitors shall meet the following limits.				
	Capacitance change	Within ±10 % of the initial value			
	tan δ	Within the initial limit			
	Leakage current	Within the initial limit			

Marking and Dimensions

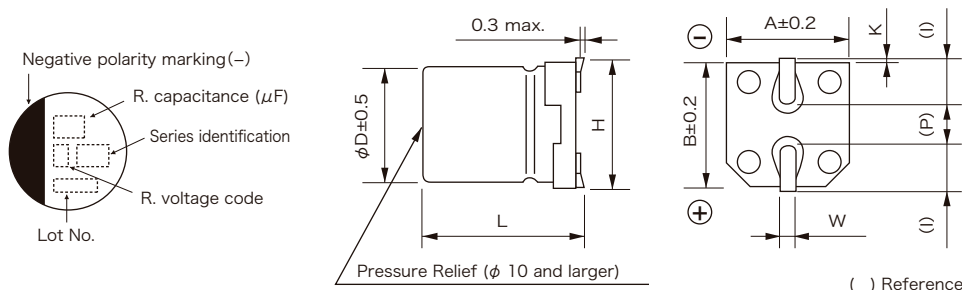

(Unit : mm)

R. voltage (V)	25	35
Code	E	V

Size code	φD	L	A,B	H	I	W	P	K
C	5.0	5.8±0.3	5.3	6.5 max.	2.2	0.65±0.1	1.5	0.35 ^{+0.15} _{-0.20}
D	6.3	5.8±0.3	6.6	7.8 max.	2.6	0.65±0.1	1.8	0.35 ^{+0.15} _{-0.20}
D8	6.3	7.7±0.3	6.6	7.8 max.	2.6	0.65±0.1	1.8	0.35 ^{+0.15} _{-0.20}
F	8.0	10.2±0.3	8.3	10.0 max.	3.4	0.90±0.2	3.1	0.70±0.2
G	10.0	10.2±0.3	10.3	12.0 max.	3.5	0.90±0.2	4.6	0.70±0.2

*The dimensions of the vibration-proof products, please refer to the page of the mounting specification

Characteristics list

Endurance : 125 °C 4000 h

Series	Rated voltage (V)	Capacitance (±20 %) (μF)	Case size (mm)			Size code	Specifications			Part number		Min. Packaging Qty (pcs)
			φD	L			Ripple Current ※1 (mA rms)	ESR ※2 (mΩ)	tan δ ※3	Standard product	Vibration-proof product	
				Standard product	Vibration-proof product							Standard product
ZKU	25	56	5.0	5.8	–	C	850	80	0.14	EEHZK1E560UR	–	1000
		100	6.3	5.8	6.1	D	1300	50	0.14	EEHZK1E101UP	EEHZK1E101UV	1000
		180	6.3	7.7	8.0	D8	1800	30	0.14	EEHZKE181XUP	EEHZKE181XUV	900
		330	8.0	10.2	10.5	F	2000	27	0.14	EEHZK1E331UP	EEHZK1E331UV	500
		560	10.0	10.2	10.5	G	2800	20	0.14	EEHZK1E561UP	EEHZK1E561UV	500
	35	39	5.0	5.8	–	C	750	100	0.12	EEHZK1V390UR	–	1000
		68	6.3	5.8	6.1	D	1200	60	0.12	EEHZK1V680UP	EEHZK1V680UV	1000
		120	6.3	7.7	8.0	D8	1700	35	0.12	EEHZK1V121XUP	EEHZK1V121XUV	900
		220	8.0	10.2	10.5	F	2000	27	0.12	EEHZK1V221UP	EEHZK1V221UV	500
		390	10.0	10.2	10.2	G	2800	20	0.12	EEHZK1V391UP	EEHZK1V391UV	500

※1: Ripple current (100 kHz/ +125 °C)

※2: ESR (100 kHz/+20 °C)

※3: tan δ (120 Hz/ +20 °C)

◆Please refer to the P127 to 129 in this catalog for "Reflow conditions" and "Taping specifications".

Frequency correction factor for ripple current

Rated capacitance(μF)	Frequency	100 Hz ≤ f < 200 Hz	200 Hz ≤ f < 300 Hz	300 Hz ≤ f < 500 Hz	500 Hz ≤ f < 1 kHz
C < 47 μF	Correction factor	0.15	0.20	0.25	0.35
47 μF ≤ C < 100 μF		0.15	0.25	0.30	0.40
100 μF ≤ C		0.15	0.25	0.30	0.40

Rated capacitance(μF)	Frequency	1 kHz ≤ f < 2 kHz	2 kHz ≤ f < 3 kHz	3 kHz ≤ f < 5 kHz	5 kHz ≤ f < 10 kHz
C < 47 μF	Correction factor	0.45	0.55	0.60	0.65
47 μF ≤ C < 100 μF		0.50	0.60	0.65	0.70
100 μF ≤ C		0.50	0.60	0.65	0.70

Rated capacitance(μF)	Frequency	10 kHz ≤ f < 15 kHz	15 kHz ≤ f < 20 kHz	20 kHz ≤ f < 30 kHz	30 kHz ≤ f < 40 kHz
C < 47 μF	Correction factor	0.70	0.75	0.75	0.75
47 μF ≤ C < 100 μF		0.75	0.75	0.80	0.80
100 μF ≤ C		0.75	0.80	0.85	0.85

Rated capacitance(μF)	Frequency	40 kHz ≤ f < 50 kHz	50 kHz ≤ f < 100 kHz	100 kHz ≤ f < 500 kHz	500 kHz ≤ f
C < 47 μF	Correction factor	0.80	0.85	1.00	1.05
47 μF ≤ C < 100 μF		0.85	0.90	1.00	1.00
100 μF ≤ C		0.85	0.90	1.00	1.00

Design and Specifications are each subject to change without notice. Ask factory for the current technical Specifications before purchase and/or use. Should a safety concern arise regarding this product, please be sure to contact us immediately.

SP-Cap

Guidelines and Precaution
Mounting specifications
Packing specifications

Selection guide

Surface mount type

Catalog EOL models

POSCAP

Guidelines and Precautions
Mounting specifications
Packing specifications

Selection guide

Surface mount type

Catalog Deletion models

Catalog EOL models

OS-CON

Guidelines and Precautions
Mounting specifications
Packing specifications

Selection guide

Surface mount type

Radial lead type

Catalog EOL models

Hybrid

Guidelines and Precautions
Mounting specifications
Packing specifications

Line-up

Series system diagram

Products list

ZA
ZC
ZK
ZKU
ZT
ZS
ZSU
ZU
ZE
ZF
ZA-A
ZC-A
ZK-A
ZKU-A
ZT-A
ZS-A
ZSU-A
ZE-A
ZF-A

Design and specifications are each subject to change without notice. Ask factory for the current technical specifications before purchase and/or use. Should a safety concern arise regarding this product, please be sure to contact us immediately.



Endurance: 4000 h at 125 °C

Higher ripple current (75 % to 118 % higher than ZC series)

Vibration-proof product is available upon request.

AEC-Q200 compliant

RoHS compliant

SP-Cap

Guidelines and Precautions
Mounting specifications
Packing specifications

Selection guide

Surface mount type

Catalog EOL models

POSCAP

Guidelines and Precautions
Mounting specifications
Packing specifications

Selection guide

Surface mount type

Catalog Deletion models

Catalog EOL models

OS-CON

Guidelines and Precautions
Mounting specifications
Packing specifications

Selection guide

Surface mount type

Hybrid

Guidelines and Precautions
Mounting specifications
Packing specifications

Line-up

Series system diagram
Products list

Selection guide

- ZA
- ZC
- ZK
- ZKU
- ZT**
- ZS
- ZSU
- ZU
- ZE
- ZF
- ZA-A
- ZC-A
- ZK-A
- ZKU-A
- ZT-A
- ZS-A
- ZSU-A
- ZE-A
- ZF-A

Radial lead type

Specifications

Items	Specifications							
Size code	F	G						
Category temperature range	-55 °C to +125 °C							
Rated voltage range	25 V to 63 V							
Nominal capacitance range	33 μF to 220 μF	56 μF to 330 μF						
Capacitance tolerance	±20 % (120 Hz/+20 °C)							
DC leakage current	I ≤ 0.01 CV (μA), 2 minutes after reaching rated voltage, 20 °C *CV = (Capacitance in μF) x (Rated voltage in V)							
Dissipation factor (tan δ)	Please see the attached characteristics list							
Surge voltage(V)	Rated voltage × 1.25 (15 °C to 35 °C)							
Endurance	+125 °C±2 °C, 4000 h, apply the rated ripple current without exceeding the rated voltage.							
	Capacitance change	Within ±30 % of the initial value						
	Dissipation factor (tan δ)	≤ 200 % of the initial limit						
	E.S.R.	≤ 200 % of the initial limit						
	Leakage current	Within the initial limit						
	ESR after endurance (Ω / 100 kHz) (-40 °C)	<table border="1"> <thead> <tr> <th colspan="2">Size code</th> </tr> <tr> <th>F</th> <th>G</th> </tr> </thead> <tbody> <tr> <td>0.4</td> <td>0.3</td> </tr> </tbody> </table>		Size code		F	G	0.4
Size code								
F	G							
0.4	0.3							
Shelf life	After storage for 1000 hours at +125 °C±2 °C with no voltage applied and then being stabilized at +20 °C, capacitors shall meet the limits specified in endurance. (With voltage treatment)							
Damp heat (Load)	85 °C, 85 % to 90 % RH, 2000 h, rated voltage applied							
	Capacitance change	Within ±30% of the initial value						
	tan δ	≤ 200 % of the initial limit						
	E.S.R.	≤ 200 % of the initial limit						
	Leakage current	Within the initial limit						
Resistance to soldering heat	After reflow soldering and then being stabilized at +20 °C, capacitors shall meet the following limits.							
	Capacitance change	Within ±10% of the initial value						
	tan δ	Within the initial limit						
	Leakage current	Within the initial limit						

Marking and Dimensions

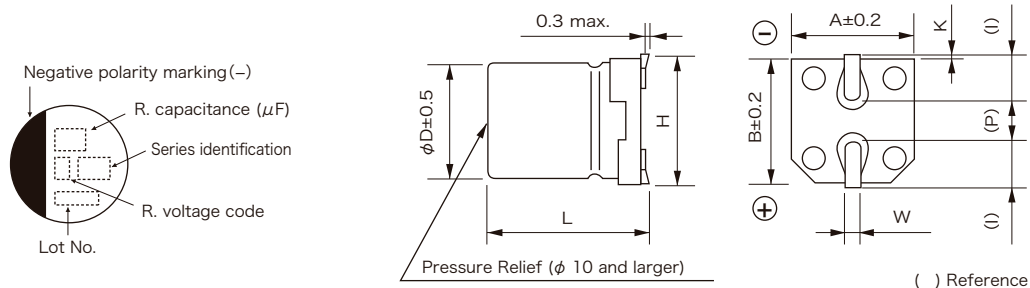

R. voltage (V)	25	35	50	63
Code	E	V	H	J

Size code	φD	L	A,B	H	I	W	P	K
F	8.0	10.2±0.3	8.3	10.0max.	3.4	0.90±0.2	3.1	0.70±0.2
G	10.0	10.2±0.3	10.3	12.0max.	3.5	0.90±0.2	4.6	0.70±0.2

※The dimensions of the vibration-proof products, please refer to the page of the mounting specification

Characteristics list

Endurance : 125 °C 4000 h

Series	Rated voltage (V)	Capacitance (±20 %) (μF)	Case size (mm)			Size code	Specifications			Part number		Min. Packaging Qty (pcs)
			φD	L			Ripple Current ※1 (mA rms)	ESR ※2 (mΩ)	tan δ ※3	Standard product	Vibration-proof product	
				Standard product	Vibration-proof product							Taping
ZT	25	220	8.0	10.2	10.5	F	2900	22	0.14	EEHZT1E221P	EEHZT1E221V	500
		330	10.0	10.2	10.5	G	3500	16	0.14	EEHZT1E331P	EEHZT1E331V	500
	35	150	8.0	10.2	10.5	F	2900	22	0.12	EEHZT1V151P	EEHZT1V151V	500
		270	10.0	10.2	10.5	G	3500	16	0.12	EEHZT1V271P	EEHZT1V271V	500
	50	68	8.0	10.2	10.5	F	2700	25	0.10	EEHZT1H680P	EEHZT1H680V	500
		100	10.0	10.2	10.5	G	2900	23	0.10	EEHZT1H101P	EEHZT1H101V	500
		120	10.0	10.2	10.5		2900	23	0.10	EEHZT1H121P	EEHZT1H121V	500
	63	33	8.0	10.2	10.5	F	2400	32	0.08	EEHZT1J330P	EEHZT1J330V	500
		47	8.0	10.2	10.5		2400	32	0.08	EEHZT1J470P	EEHZT1J470V	500
		56	10.0	10.2	10.5	G	2800	25	0.08	EEHZT1J560P	EEHZT1J560V	500
		68	10.0	10.2	10.5		2800	25	0.08	EEHZT1J680P	EEHZT1J680V	500
		82	10.0	10.2	10.5		2800	25	0.08	EEHZT1J820P	EEHZT1J820V	500

※1: Ripple current (100 kHz/ +125 °C)

※2: ESR (100 kHz/+20 °C)

※3: tan δ (120 Hz/ +20 °C)

◆Please refer to the P127 to 129 in this catalog for "Reflow conditions" and "Taping specifications".

Frequency correction factor for ripple current

Rated capacitance (C)	Frequency	100 Hz ≤ f < 200 Hz	200 Hz ≤ f < 300 Hz	300 Hz ≤ f < 500 Hz	500 Hz ≤ f < 1 kHz
C < 47 μF	Correction factor	0.10	0.10	0.15	0.20
47 μF ≤ C < 150 μF		0.15	0.20	0.25	0.30
150 μF ≤ C		0.15	0.25	0.25	0.30

Rated capacitance (C)	Frequency	1 kHz ≤ f < 2 kHz	2 kHz ≤ f < 3 kHz	3 kHz ≤ f < 5 kHz	5 kHz ≤ f < 10 kHz
C < 47 μF	Correction factor	0.30	0.40	0.45	0.50
47 μF ≤ C < 150 μF		0.40	0.45	0.55	0.60
150 μF ≤ C		0.45	0.50	0.60	0.65

Rated capacitance (C)	Frequency	10 kHz ≤ f < 15 kHz	15 kHz ≤ f < 20 kHz	20 kHz ≤ f < 30 kHz	30 kHz ≤ f < 40 kHz
C < 47 μF	Correction factor	0.60	0.65	0.70	0.75
47 μF ≤ C < 150 μF		0.70	0.75	0.80	0.80
150 μF ≤ C		0.75	0.80	0.85	0.85

Rated capacitance (C)	Frequency	40 kHz ≤ f < 50 kHz	50 kHz ≤ f < 100 kHz	100 kHz ≤ f < 500 kHz	500 kHz ≤ f
C < 47 μF	Correction factor	0.80	0.85	1.00	1.05
47 μF ≤ C < 150 μF		0.85	0.90	1.00	1.00
150 μF ≤ C		0.85	0.90	1.00	1.00

SP-Cap

Guidelines and Precautions
Mounting specifications
Packing specifications

Selection guide

Surface mount type

Catalog EOL models

POSCAP

Guidelines and Precautions
Mounting specifications
Packing specifications

Selection guide

Surface mount type

Catalog Deletion models

Catalog EOL models

OS-CON

Guidelines and Precautions
Mounting specifications
Packing specifications

Selection guide

Surface mount type

Radial lead type

Catalog EOL models

Hybrid

Guidelines and Precautions
Mounting specifications
Packing specifications

Line-up
Series system diagram

Selection guide	Products list
Surface mount type	ZA
	ZC
	ZK
	ZKU
	ZT
	ZS
	ZSU
	ZU
	ZE
	ZF
Radial lead type	ZA-A
	ZC-A
	ZK-A
	ZKU-A
	ZT-A
	ZS-A
	ZSU-A
ZE-A	
ZF-A	



- High ripple current and Large capacitance compared with ZC series
- Vibration-proof products are available upon request.
- Characteristics dependencies in low temperature and frequency are as small as polymer type.
- Endurance: 4000 h at 135 °C
- AEC-Q200 compliant
- RoHS compliant

SP-Cap

Guidelines and Precautions
Mounting specifications
Packing specifications

Selection guide

Surface mount type

POSCAP

Guidelines and Precautions
Mounting specifications
Packing specifications

Selection guide

Surface mount type

Catalog Deletion models

Catalog EOL models

OS-CON

Guidelines and Precautions
Mounting specifications
Packing specifications

Selection guide

Surface mount type

Radial lead type

Catalog EOL models

Hybrid

Guidelines and Precautions
Mounting specifications
Packing specifications

Line-up

Series system diagram

Products list

ZA

ZC

ZK

ZKU

ZT

ZS

ZSU

ZU

ZE

ZF

ZA-A

ZC-A

ZK-A

ZKU-A

ZT-A

ZS-A

ZSU-A

ZE-A

ZF-A

Specifications

Items	Specifications	
Size code	G12	G16
Category temperature range	-55 °C to +135 °C	
Rated voltage range	25 V to 63 V	
Nominal capacitance range	100 μF to 470 μF	150 μF to 560 μF
Capacitance tolerance	±20 % (120 Hz / +20 °C)	
DC leakage current	I ≤ 0.01 CV (μA), 2 minutes after reaching rated voltage, 20 °C *CV = (Capacitance in μF) x (Rated voltage in V)	
Dissipation factor (tan δ)	Please see the attached characteristics list	
Surge voltage(V)	Rated voltage x 1.25 (15 °C to 35 °C)	
Endurance 1	+125 °C±2 °C, 4000 h, apply the rated ripple current without exceeding the rated voltage.	
	Capacitance change	Within ±30% of the initial value
	Dissipation factor (tan δ)	≤ 200 % of the initial limit
	E.S.R.	≤ 200 % of the initial limit
Endurance 2	+135 °C ± 2 °C, 4000 h, apply the rated ripple current without exceeding the rated voltage.	
	Capacitance change	Within ±30% of the initial value
	Dissipation factor (tan δ)	≤ 200 % of the initial limit
	E.S.R.	≤ 200 % of the initial limit
Shelf life	After storage for 1000 hours at +135 °C±2 °C with no voltage applied and then being stabilized at +20°C, capacitors shall meet the limits specified in endurance. (With voltage treatment)	
Damp heat (Load)	+85 °C±2 °C, 85 % to 90 % RH, 2000 h, rated voltage applied.	
	Capacitance change	Within ±30% of the initial value
	Dissipation factor (tan δ)	≤ 200 % of the initial limit
	E.S.R.	≤ 200 % of the initial limit
Resistance to soldering heat	After reflow soldering and then being stabilized at +20°C, capacitors shall meet the following limits.	
	Capacitance change	Within ±10% of the initial value
	Dissipation factor (tan δ)	Within the initial limit
	Leakage current	Within the initial limit

Marking and Dimensions

() Reference

(Unit : mm)

R. voltage (V)	25	35	50	63
Code	E	V	H	J

Size code	φD	L	A,B	H	I	W	P
G12	10.0	12.5	10.3	11.0±0.2	3.2	1.2±0.2	4.6
G16	10.0	16.5	10.3	11.0±0.2	3.2	1.2±0.2	4.6

※The dimensions of the vibration-proof products, please refer to the page of the mounting specification

Characteristics list

Endurance : 125 °C 4000 h
Endurance : 135 °C 4000 h

Series	Rated voltage (V)	Capacitance (±20 %) (μF)	Case size (mm)			Size code	Specifications				Part number		Min. Packaging Qty (pcs)
			φD	L			Ripple Current ※1 (mA rms)		ESR ※2 (mΩ)	tan δ ※3	Standard product	Vibration-proof product	
				Standard product	Vibration-proof product		Endurance 1 (+125 °C)	Endurance 2 (+135 °C)					Taping
ZS	25	470	10.0	12.5	12.8	G12	3500	2500	14	0.14	EEHVS1E471P	EEHVS1E471V	400
		560	10.0	16.5	16.8	G16	4000	2900	11	0.14	EEHVS1E561P	EEHVS1E561V	250
	35	330	10.0	12.5	12.8	G12	3500	2500	14	0.12	EEHVS1V331P	EEHVS1V331V	400
		470	10.0	16.5	16.8	G16	4000	2900	11	0.12	EEHVS1V471P	EEHVS1V471V	250
	50	150	10.0	12.5	12.8	G12	3200	2250	17	0.10	EEHVS1H151P	EEHVS1H151V	400
		220	10.0	16.5	16.8	G16	3700	2600	13	0.10	EEHVS1H221P	EEHVS1H221V	250
63	100	10.0	12.5	12.8	G12	3000	2100	19	0.08	EEHVS1J101P	EEHVS1J101V	400	
	150	10.0	16.5	16.8	G16	3500	2400	15	0.08	EEHVS1J151P	EEHVS1J151V	250	

※1: Ripple current (100 kHz / +125 °C)

※2: ESR (100 kHz / +20 °C)

※3: tan δ (120 Hz / +20 °C)

◆Please refer to the P127 to 129 in this catalog for "Reflow conditions" and "Taping specifications"

◆The dimensions of the vibration-proof products, please refer to the page of the mounting specification.

Frequency correction factor for ripple current

Rated capacitance (C)	Frequency (f)	100 Hz ≤ f < 200 Hz	200 Hz ≤ f < 300 Hz	300 Hz ≤ f < 500 Hz	500 Hz ≤ f < 1 kHz
100 μF ≤ C < 150 μF	Correction factor	0.15	0.20	0.25	0.30
150 μF ≤ C		0.15	0.25	0.25	0.30

Rated capacitance (C)	Frequency (f)	1 kHz ≤ f < 2 kHz	2 kHz ≤ f < 3 kHz	3 kHz ≤ f < 5 kHz	5 kHz ≤ f < 10 kHz
100 μF ≤ C < 150 μF	Correction factor	0.40	0.45	0.55	0.60
150 μF ≤ C		0.45	0.50	0.60	0.65

Rated capacitance (C)	Frequency (f)	10 kHz ≤ f < 15 kHz	15 kHz ≤ f < 20 kHz	20 kHz ≤ f < 30 kHz	30 kHz ≤ f < 40 kHz
100 μF ≤ C < 150 μF	Correction factor	0.70	0.75	0.80	0.80
150 μF ≤ C		0.75	0.80	0.85	0.85

Rated capacitance (C)	Frequency (f)	40 kHz ≤ f < 50 kHz	50 kHz ≤ f < 100 kHz	100 kHz ≤ f < 500 kHz	500 kHz ≤ f
100 μF ≤ C < 150 μF	Correction factor	0.85	0.90	1.00	1.00
150 μF ≤ C		0.85	0.90	1.00	1.00

SP-Cap

Guidelines and Precautions
Mounting specifications
Packing specifications

Selection guide

Surface mount type

Catalog EOL models

POSCAP

Guidelines and Precautions
Mounting specifications
Packing specifications

Selection guide

Surface mount type

Catalog Deletion models

Catalog EOL models

OS-CON

Guidelines and Precautions
Mounting specifications
Packing specifications

Selection guide

Surface mount type

Radial lead type

Catalog EOL models

Hybrid

Guidelines and Precautions
Mounting specifications
Packing specifications

Line-up

Series system diagram

Products list

ZA
ZC
ZK
ZKU
ZT
ZS
ZSU
ZU
ZE
ZF
ZA-A
ZC-A
ZK-A
ZKU-A
ZT-A
ZS-A
ZSU-A
ZE-A
ZF-A



Endurance: 4000 h at 125 °C (High temperature / Long life)

Large capacitance compared with ZS series

Vibration-proof product is available upon request.

AEC-Q200 compliant

RoHS compliant

SP-Cap

Guidelines and Precautions
Mounting specifications
Packing specifications

Selection guide

Surface mount type

Catalog EOL models

POSCAP

Guidelines and Precautions
Mounting specifications
Packing specifications

Selection guide

Surface mount type

Catalog Deletion models

Catalog EOL models

OS-CON

Guidelines and Precautions
Mounting specifications
Packing specifications

Selection guide

Surface mount type

Hybrid

Guidelines and Precautions
Mounting specifications
Packing specifications

Line-up

Series system diagram

Products list

- ZA
- ZC
- ZK
- ZKU
- ZT
- ZS
- ZSU**
- ZU
- ZE
- ZF
- ZA-A
- ZC-A
- ZK-A
- ZKU-A
- ZT-A
- ZS-A
- ZSU-A
- ZE-A
- ZF-A

Surface mount type

Radial lead type

Specifications

Items	Specifications	
Size code	G12	G16
Category temperature range	-55 °C to +125 °C	
Rated voltage range	25 V to 63 V	
Nominal capacitance range	120 μF to 680 μF	180 μF to 1000 μF
Capacitance tolerance	±20 % (120 Hz / +20 °C)	
DC leakage current	I ≤ 0.01 CV (μA), 2 minutes after reaching rated voltage, 20 °C *CV = (Capacitance in μF) x (Rated voltage in V)	
Dissipation factor (tan δ)	Please see the attached characteristics list	
Surge voltage(V)	Rated voltage x 1.25 (15 °C to 35 °C)	
Endurance	+125 °C±2 °C, 4000 h, apply the rated ripple current without exceeding the rated voltage.	
	Capacitance change	Within ±30% of the initial value
	Dissipation factor (tan δ)	≤ 200 % of the initial limit
	E.S.R.	≤ 200 % of the initial limit
	Leakage current	Within the initial limit
	ESR after endurance (Ω / 100 kHz) (-40 °C)	Size code
	G12	G16
	0.3	0.3
Shelf life	After storage for 1000 hours at +125 °C±2 °C with no voltage applied and then being stabilized at +20°C, capacitors shall meet the limits specified in endurance. (With voltage treatment)	
Damp heat (Load)	+85 °C±2 °C, 85 % to 90 % RH, 2000 h, rated voltage applied.	
	Capacitance change	Within ±30% of the initial value
	Dissipation factor (tan δ)	≤ 200 % of the initial limit
	E.S.R.	≤ 200 % of the initial limit
	Leakage current	Within the initial limit
Resistance to soldering heat	After reflow soldering and then being stabilized at +20°C, capacitors shall meet the following limits.	
	Capacitance change	Within ±10% of the initial value
	Dissipation factor (tan δ)	Within the initial limit
	Leakage current	Within the initial limit

Marking and Dimensions

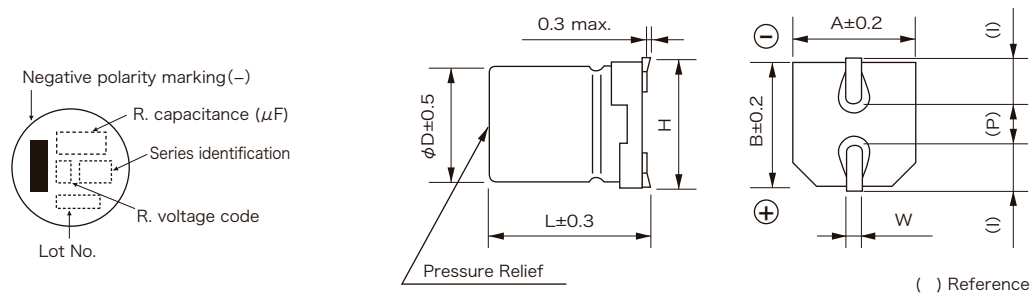

(Unit : mm)

R. voltage (V)	25	35	50	63
Code	E	V	H	J

Size code	φD	L	A,B	H	I	W	P
G12	10.0	12.5	10.3	11.0±0.2	3.2	1.2±0.2	4.6
G16	10.0	16.5	10.3	11.0±0.2	3.2	1.2±0.2	4.6

※The dimensions of the vibration-proof products, please refer to the page of the mounting specification

Characteristics list

Endurance : 125 °C 4000 h

Series	Rated voltage (V)	Capacitance (+20 %) (μF)	Case size (mm)			Size code	Specifications			Part number		Min. Packaging Qty (pcs)
			φD	L			Ripple Current ※1 (mA rms)	ESR ※2 (mΩ)	tan δ ※3	Standard product	Vibration-proof product	
				Standard product	Vibration-proof product							Taping
ZSU	25	680	10.0	12.5	12.8	G12	3500	14	0.14	EEHVS1E681UP	EEHVS1E681UV	400
		1000	10.0	16.5	16.8	G16	4000	11	0.14	EEHVS1E102UP	EEHVS1E102UV	250
	35	470	10.0	12.5	12.8	G12	3500	14	0.12	EEHVS1V471UP	EEHVS1V471UV	400
		680	10.0	16.5	16.8	G16	4000	11	0.12	EEHVS1V681UP	EEHVS1V681UV	250
	50	180	10.0	12.5	12.8	G12	3200	17	0.10	EEHVS1H181UP	EEHVS1H181UV	400
		270	10.0	16.5	16.8	G16	3700	13	0.10	EEHVS1H271UP	EEHVS1H271UV	250
	63	120	10.0	12.5	12.8	G12	3000	19	0.08	EEHVS1J121UP	EEHVS1J121UV	400
		180	10.0	16.5	16.8	G16	3500	15	0.08	EEHVS1J181UP	EEHVS1J181UV	250

※1: Ripple current (100 kHz / +125 °C)

※2: ESR (100 kHz / +20 °C)

※3: tan δ (120 Hz / +20 °C)

◆Please refer to the P127 to 129 in this catalog for "Reflow conditions" and "Taping specifications"

Frequency correction factor for ripple current

Rated capacitance (C)	Frequency (f)	100 Hz ≤ f < 120 Hz	120 Hz ≤ f < 200 Hz	200 Hz ≤ f < 300 Hz	300 Hz ≤ f < 500 Hz
120 μF ≤ C	Correction factor	0.15	0.20	0.25	0.30

Rated capacitance (C)	Frequency (f)	500 Hz ≤ f < 1 kHz	1 kHz ≤ f < 2 kHz	2 kHz ≤ f < 3 kHz	3 kHz ≤ f < 5 kHz
120 μF ≤ C	Correction factor	0.40	0.50	0.60	0.65

Rated capacitance (C)	Frequency (f)	5 kHz ≤ f < 10 kHz	10 kHz ≤ f < 15 kHz	15 kHz ≤ f < 20 kHz	20 kHz ≤ f < 30 kHz
120 μF ≤ C	Correction factor	0.70	0.75	0.80	0.85

Rated capacitance (C)	Frequency (f)	30 kHz ≤ f < 50 kHz	50 kHz ≤ f < 100 kHz	100 kHz ≤ f < 500 kHz	500 kHz ≤ f < 1000 kHz
120 μF ≤ C	Correction factor	0.85	0.90	1.00	1.00

SP-Cap

Guidelines and Precaution
Mounting specifications
Packing specifications

Selection guide

Surface mount type

Catalog EOL models

POSCAP

Guidelines and Precautions
Mounting specifications
Packing specifications

Selection guide

Surface mount type

Catalog Deletion models

Catalog EOL models

OS-CON

Guidelines and Precautions
Mounting specifications
Packing specifications

Selection guide

Surface mount type

Radial lead type

Catalog EOL models

Hybrid

Guidelines and Precautions
Mounting specifications
Packing specifications

Selection guide

Series system diagram

Products list

ZA
ZC
ZK
ZKU
ZT
ZS
ZSU
ZU
ZE
ZF
ZA-A
ZC-A
ZK-A
ZKU-A
ZT-A
ZS-A
ZSU-A
ZE-A
ZF-A



Endurance: 4000 h at 135 °C

High ripple current compared with ZS series

Vibration-proof product is available upon request.

AEC-Q200 compliant

RoHS compliant

SP-Cap

Guidelines and Precautions
Mounting specifications
Packing specifications

Selection guide

Surface mount type

Catalog EOL models

POSCAP

Guidelines and Precautions
Mounting specifications
Packing specifications

Selection guide

Surface mount type

Catalog Deletion models

Catalog EOL models

OS-CON

Guidelines and Precautions
Mounting specifications
Packing specifications

Selection guide

Surface mount type

Radial lead type

Catalog EOL models

Hybrid

Guidelines and Precautions

Mounting specifications

Packing specifications

Line-up

Series system diagram

Products list

ZA

ZC

ZK

ZKU

ZT

ZS

ZSU

ZU

ZE

ZF

ZA-A

ZC-A

ZK-A

ZKU-A

ZT-A

ZS-A

ZSU-A

ZE-A

ZF-A

Surface mount type

Radial lead type

Specifications

Items	Specifications	
Size code	G12	G16
Category temperature range	-55 °C to +135 °C	
Rated voltage range	25 V to 63 V	
Nominal capacitance range	100 μF to 470 μF	150 μF to 560 μF
Capacitance tolerance	±20 % (120 Hz/+20 °C)	
DC leakage current	I ≤ 0.01 CV (μA), 2 minutes after reaching rated voltage, 20 °C *CV = (Capacitance in μF) x (Rated voltage in V)	
Dissipation factor (tan δ)	Please see the attached characteristics list	
Surge voltage(V)	Rated voltage × 1.25 (15 °C to 35 °C)	
Endurance 1	+125 °C±2 °C, 4000 h, apply the rated ripple current without exceeding the rated voltage.	
	Capacitance change	Within ±30% of the initial value
	Dissipation factor (tan δ)	≤ 200 % of the initial limit
	E.S.R.	≤ 200 % of the initial limit
Endurance 2	+135 °C±2 °C, 4000 h, apply the rated ripple current without exceeding the rated voltage.	
	Capacitance change	Within ±30% of the initial value
	Dissipation factor (tan δ)	≤ 200 % of the initial limit
	E.S.R.	≤ 200 % of the initial limit
Shelf life	After storage for 1000 hours at +135 °C±2 °C with no voltage applied and then being stabilized at +20 °C, capacitors shall meet the limits specified in endurance. (With voltage treatment)	
	Capacitance change	Within ±30% of the initial value
	Dissipation factor (tan δ)	≤ 200 % of the initial limit
	E.S.R.	≤ 200 % of the initial limit
Damp heat (Load)	85 °C ± 2 °C, 85 % to 90 % RH, 2000 h, rated voltage applied	
	Capacitance change	Within ±30% of the initial value
	Dissipation factor (tan δ)	≤ 200 % of the initial limit
	E.S.R.	≤ 200 % of the initial limit
Resistance to soldering heat	After reflow soldering and then being stabilized at +20 °C, capacitors shall meet the following limits.	
	Capacitance change	Within ±10% of the initial value
	Dissipation factor (tan δ)	Within the initial limit
	Leakage current	Within the initial limit

Marking and Dimensions (not to scale)

() Reference

(Unit : mm)

Size code	φD	L	A,B	H	I	W	P
G12	10.0	12.5	10.3	11.0±0.2	3.2	1.2±0.2	4.6
G16	10.0	16.5	10.3	11.0±0.2	3.2	1.2±0.2	4.6

※The dimensions of the vibration-proof products, please refer to the page of the mounting specification

Characteristics list

Endurance 1 : 125 °C 4000 h
Endurance 2 : 135 °C 4000 h

Series	Rated voltage (V)	Capacitance (+20%) (μF)	Case size (mm)			Size code	Specifications				Part number		Min. Packaging Qty (pcs)
			φD	L			Ripple Current ※1 (mA rms)		ESR ※2 (mΩ)	tan δ ※3	Standard product	Vibration-proof product	
				Standard product	Vibration-proof product		Endurance 1	Endurance 2					Taping
ZU	25	470	10.0	12.5	12.8	G12	5000	3500	10	0.14	EEHZU1E471P	EEHZU1E471V	400
		560	10.0	16.5	16.8	G16	5800	4000	8	0.14	EEHZU1E561P	EEHZU1E561V	250
	35	330	10.0	12.5	12.8	G12	4800	3300	11	0.12	EEHZU1V331P	EEHZU1V331V	400
		470	10.0	16.5	16.8	G16	5500	3800	9	0.12	EEHZU1V471P	EEHZU1V471V	250
	50	150	10.0	12.5	12.8	G12	4600	3200	12	0.10	EEHZU1H151P	EEHZU1H151V	400
		220	10.0	16.5	16.8	G16	5200	3600	10	0.10	EEHZU1H221P	EEHZU1H221V	250
	63	100	10.0	12.5	12.8	G12	4600	3200	12	0.08	EEHZU1J101P	EEHZU1J101V	400
		150	10.0	16.5	16.8	G16	5200	3600	10	0.08	EEHZU1J151P	EEHZU1J151V	250

※1: Ripple current (100 kHz / +125 °C or +135 °C)

※2: ESR (100 kHz / +20 °C)

※3: tan δ (120 Hz / +20 °C)

◆Please refer to the P127 to 129 in this catalog for "Reflow conditions" and "Taping specifications".

Frequency correction factor for ripple current

Rated capacitance (C)	Frequency (f)	100 Hz ≤ f < 200 Hz	200 Hz ≤ f < 300 Hz	300 Hz ≤ f < 500 Hz	500 Hz ≤ f < 1 kHz
100 μF ≤ C < 150 μF	Correction factor	0.15	0.20	0.25	0.30
150 μF ≤ C		0.15	0.25	0.25	0.30

Rated capacitance (C)	Frequency (f)	1 kHz ≤ f < 2 kHz	2 kHz ≤ f < 3 kHz	3 kHz ≤ f < 5 kHz	5 kHz ≤ f < 10 kHz
100 μF ≤ C < 150 μF	Correction factor	0.40	0.45	0.55	0.60
150 μF ≤ C		0.45	0.50	0.60	0.65

Rated capacitance (C)	Frequency (f)	10 kHz ≤ f < 15 kHz	15 kHz ≤ f < 20 kHz	20 kHz ≤ f < 30 kHz	30 kHz ≤ f < 40 kHz
100 μF ≤ C < 150 μF	Correction factor	0.70	0.75	0.80	0.80
150 μF ≤ C		0.75	0.80	0.85	0.85

Rated capacitance (C)	Frequency (f)	40 kHz ≤ f < 50 kHz	50 kHz ≤ f < 100 kHz	100 kHz ≤ f < 500 kHz	500 kHz ≤ f
100 μF ≤ C < 150 μF	Correction factor	0.85	0.90	1.00	1.00
150 μF ≤ C		0.85	0.90	1.00	1.00

After endurance ESR(100 kHz, -40 °C)

Size	G12	G16
ESR (Ω)	0.3	0.3

SP-Cap

Guidelines and Precautions
Mounting specifications
Packing specifications

Selection guide

Surface mount type

Catalog EOL models

POSCAP

Guidelines and Precautions
Mounting specifications
Packing specifications

Selection guide

Surface mount type

Catalog Deletion models

Catalog EOL models

OS-CON

Guidelines and Precautions
Mounting specifications
Packing specifications

Selection guide

Surface mount type

Radial lead type

Catalog EOL models

Hybrid

Guidelines and Precautions
Mounting specifications
Packing specifications

Line-up

Series system diagram

Products list

ZA
ZC
ZK
ZKU
ZT
ZS
ZSU
ZU
ZE
ZF
ZA-A
ZC-A
ZK-A
ZKU-A
ZT-A
ZS-A
ZSU-A
ZE-A
ZF-A



- Endurance: 2000 h at 145 °C (High temperature / Long life)
- Characteristics dependencies in low temperature and frequency are as small as polymer type.
- Low ESR and high ripple current (over 85% lower ESR than V-TP)
- Vibration-proof products are available upon request.
- High-withstand voltage (63V)
- AEC-Q200 compliant
- RoHS compliant

SP-Cap

Guidelines and Precautions
Mounting specifications
Packing specifications

Selection guide

Surface mount type

Catalog EOL models

POSCAP

Guidelines and Precautions
Mounting specifications
Packing specifications

Selection guide

Surface mount type

Catalog Deletion models

Catalog EOL models

OS-CON

Guidelines and Precautions
Mounting specifications
Packing specifications

Selection guide

Surface mount type

Radial lead type

Catalog EOL models

Hybrid

Guidelines and Precautions
Mounting specifications
Packing specifications

Line-up

Series system diagram

Products list

ZA

ZC

ZK

ZKU

ZT

ZS

ZSU

ZU

ZE

ZF

ZA-A

ZC-A

ZK-A

ZKU-A

ZT-A

ZS-A

ZSU-A

ZE-A

ZF-A

Specifications

Items	Specifications	
Size code	F	G
Category temperature range	-55 °C to +145 °C	
Rated voltage range	25 V to 63 V	
Nominal capacitance range	33 μF to 220 μF	56 μF to 330 μF
Capacitance tolerance	±20 % (120 Hz/+20 °C)	
Leakage current	I ≤ 0.01 CV (μA), 2 minutes after reaching rated voltage, 20 °C *CV = (Capacitance in μF) x (Rated voltage in V)	
Dissipation factor(tanδ)	Please see the attached characteristics list	
Surge voltage(V)	Rated voltage × 1.25 (15 °C to 35 °C)	
Endurance 1	+145 °C±2 °C, 2000 h, apply the rated ripple current without exceeding the rated voltage.	
	Capacitance change	Within ±30% of the initial value
	tan δ	≤ 200 % of the initial limit
	E.S.R.	≤ 200 % of the initial limit
Endurance 2	+135 °C±2 °C, 4000 h, apply the rated ripple current without exceeding the rated voltage.	
	Capacitance change	Within ±30% of the initial value
	tan δ	≤ 200 % of the initial limit
	E.S.R.	≤ 200 % of the initial limit
Shelf life	After storage for 1000 hours at +145 °C±2 °C with no voltage applied and then being stabilized at +20 °C, capacitors shall meet the limits specified in endurance. (With voltage treatment)	
Damp heat (Load)	+85 °C±2 °C, 85 % to 90 % RH, 2000 h, rated voltage applied.	
	Capacitance change	Within ±30% of the initial value
	tan δ	≤ 200 % of the initial limit
	E.S.R.	≤ 200 % of the initial limit
Resistance to soldering heat	After reflow soldering and then being stabilized at +20 °C, capacitors shall meet the following limits.	
	Capacitance change	Within ±10% of the initial value
	tan δ	Within the initial limit
	Leakage current	Within the initial limit

Marking and Dimensions

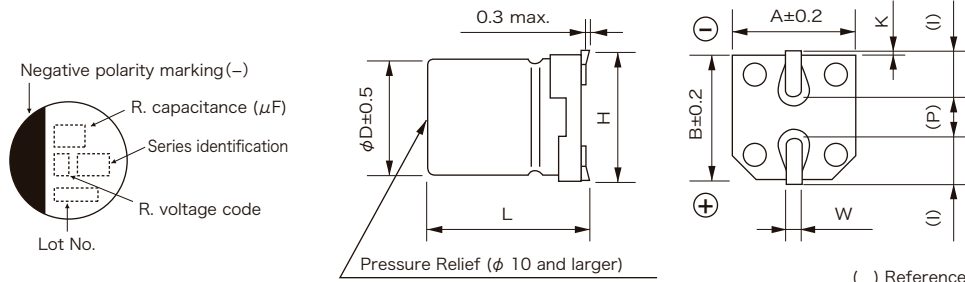

(Unit : mm)

R. voltage (V)	25	35	50	63
Code	E	V	H	J

Size code	φD	L	A,B	H	I	W	P	K
F	8.0	10.2±0.3	8.3	10.0 max.	3.4	0.90±0.2	3.1	0.70±0.2
G	10.0	10.2±0.3	10.3	12.0 max.	3.5	0.90±0.2	4.6	0.70±0.2

※The dimensions of the vibration-proof products, please refer to the page of the mounting specification

Characteristics list

Endurance 1: 145 °C 2000 h
Endurance 2: 135 °C 4000 h

Series	Rated voltage (V)	Capacitance (±20%) (μF)	Case size (mm)			Size code	Specifications				Part number		Min. Packaging Qty (pcs)
			φD	L			Ripple Current ※1 (mA rms)		ESR ※2 (mΩ)	tan δ ※3	Standard product	Vibration-proof product	
				Standard product	Vibration-proof product		Endurance 1	Endurance 2					Taping
ZE	25	220	8.0	10.2	10.5	F	700	1600	27	0.14	EEHZE1E221P	EEHZE1E221V	500
		330	10.0	10.2	10.5	G	900	2000	20	0.14	EEHZE1E331P	EEHZE1E331V	500
	35	150	8.0	10.2	10.5	F	700	1600	27	0.12	EEHZE1V151P	EEHZE1V151V	500
		270	10.0	10.2	10.5	G	900	2000	20	0.12	EEHZE1V271P	EEHZE1V271V	500
	50	68	8.0	10.2	10.5	F	600	1250	30	0.10	EEHZE1H680P	EEHZE1H680V	500
		100	10.0	10.2	10.5	G	800	1600	28	0.10	EEHZE1H101P	EEHZE1H101V	500
	63	33	8.0	10.2	10.5	F	600	1100	40	0.08	EEHZE1J330P	EEHZE1J330V	500
			56	10.0	10.2	10.5	G	800	1400	30	0.08	EEHZE1J560P	EEHZE1J560V
		82	10.0	10.2	10.5	800		1400	30	0.08	EEHZE1J820P	EEHZE1J820V	500

※1: Ripple current (100 kHz/ +145 °C (Endurance 1) or +135 °C (Endurance 2))

※2: ESR (100 kHz/+20 °C)

※3: tan δ (120 Hz/ +20 °C)

◆Please refer to the P127 to 129 in this catalog for "Reflow conditions" and "Taping specifications"

Frequency correction factor for ripple current

Rated capacitance(μF)	Frequency	100 Hz ≤ f < 200 Hz	200 Hz ≤ f < 300 Hz	300 Hz ≤ f < 500 Hz	500 Hz ≤ f < 1 kHz
C < 47 μF	Correction factor	0.10	0.10	0.15	0.20
47 μF ≤ C < 150 μF		0.15	0.20	0.25	0.30
150 μF ≤ C		0.15	0.25	0.25	0.30

Rated capacitance(μF)	Frequency	1 kHz ≤ f < 2 kHz	2 kHz ≤ f < 3 kHz	3 kHz ≤ f < 5 kHz	5 kHz ≤ f < 10 kHz
C < 47 μF	Correction factor	0.30	0.40	0.45	0.50
47 μF ≤ C < 150 μF		0.40	0.45	0.55	0.60
150 μF ≤ C		0.45	0.50	0.60	0.65

Rated capacitance(μF)	Frequency	10 kHz ≤ f < 15 kHz	15 kHz ≤ f < 20 kHz	20 kHz ≤ f < 30 kHz	30 kHz ≤ f < 40 kHz
C < 47 μF	Correction factor	0.60	0.65	0.70	0.75
47 μF ≤ C < 150 μF		0.70	0.75	0.80	0.80
150 μF ≤ C		0.75	0.80	0.85	0.85

Rated capacitance(μF)	Frequency	40 kHz ≤ f < 50 kHz	50 kHz ≤ f < 100 kHz	100 kHz ≤ f < 500 kHz	500 kHz ≤ f
C < 47 μF	Correction factor	0.80	0.85	1.00	1.05
47 μF ≤ C < 150 μF		0.85	0.90	1.00	1.00
150 μF ≤ C		0.85	0.90	1.00	1.00

After endurance ESR(100 kHz, -40 °C)

Size code	F	G
ESR(Ω)	0.4	0.3

SP-Cap

Guidelines and Precaution
Mounting specifications
Packaging specifications

Selection guide

Surface mount type

Catalog EOL models

POSCAP

Guidelines and Precautions
Mounting specifications
Packaging specifications

Selection guide

Surface mount type

Catalog Deletion models

Catalog EOL models

OS-CON

Guidelines and Precautions
Mounting specifications
Packaging specifications

Selection guide

Surface mount type

Radial lead type

Catalog EOL models

Hybrid

Guidelines and Precautions
Mounting specifications
Packaging specifications

Line-up
Series system diagram

Selection guide	Products list
Surface mount type	ZA
	ZC
	ZK
	ZKU
	ZT
	ZS
	ZSU
	ZU
	ZE
	ZF
Radial lead type	ZA-A
	ZC-A
	ZK-A
	ZKU-A
	ZT-A
	ZS-A
	ZSU-A
ZE-A	
ZF-A	



- Endurance : 1000 h at 150 °C
- Low ESR and high ripple current
- High-withstand voltage (to 63 V)
- Vibration-proof product is available upon request
- AEC-Q200 compliant
- RoHS compliant

SP-Cap

Guidelines and Precautions
Mounting specifications
Packing specifications

Selection guide

Surface mount type

Catalog EOL models

POSCAP

Guidelines and Precautions
Mounting specifications
Packing specifications

Selection guide

Surface mount type

Catalog Deletion models

Catalog EOL models

OS-CON

Guidelines and Precautions
Mounting specifications
Packing specifications

Selection guide

Surface mount type

Radial lead type

Catalog EOL models

Hybrid

Guidelines and Precautions
Mounting specifications
Packing specifications

Line-up

Series system diagram

Products list

Selection guide

Surface mount type

ZA-A

ZC-A

ZK-A

ZKU-A

ZT-A

ZS-A

ZSU-A

ZU

ZE

ZF

ZA-A

ZC-A

ZK-A

ZKU-A

ZT-A

ZS-A

ZSU-A

ZE-A

ZF-A

Specifications

Items	Specifications	
Size code	F	G
Category temperature range	-55 °C to +150 °C	
Rated voltage range	25 V to 63 V	
Nominal capacitance range	33 μF to 150 μF	56 μF to 270 μF
Capacitance tolerance	±20 % (120 Hz/+20 °C)	
DC leakage current	I ≤ 0.01 CV (μA), 2 minutes after reaching rated voltage, 20 °C *CV = (Capacitance in μF) x (Rated voltage in V)	
Dissipation factor (tan δ)	Please see the attached characteristics list	
Surge voltage (V)	Rated voltage x 1.25 (15 °C to 35 °C)	
Endurance	+150 °C±2 °C, 1000 h, apply the rated ripple current without exceeding the rated voltage.	
	Capacitance change	Within ±30% of the initial value
	Dissipation factor (tan δ)	≤ 200 % of the initial limit
	E.S.R.	≤ 200 % of the initial limit
	Leakage current	Within the initial limit
ESR after endurance (Ω / 100 kHz) (-40 °C)	Size code	
	F	G
	0.4	0.3
Shelf life	After storage for 1000 hours at +150 °C±2 °C with no voltage applied and then being stabilized at +20°C, capacitors shall meet the limits specified in endurance. (With voltage treatment)	
Damp heat (Load)	+85 °C±2 °C, 85 % to 90 % RH, 2000 h, rated voltage applied.	
	Capacitance change	Within ±30% of the initial value
	Dissipation factor (tan δ)	≤ 200 % of the initial limit
	E.S.R.	≤ 200 % of the initial limit
Resistance to soldering heat	After reflow soldering and then being stabilized at +20°C, capacitors shall meet the following limits.	
	Capacitance change	Within ±10% of the initial value
	Dissipation factor (tan δ)	Within the initial limit
Leakage current	Within the initial limit	

Marking and Dimensions

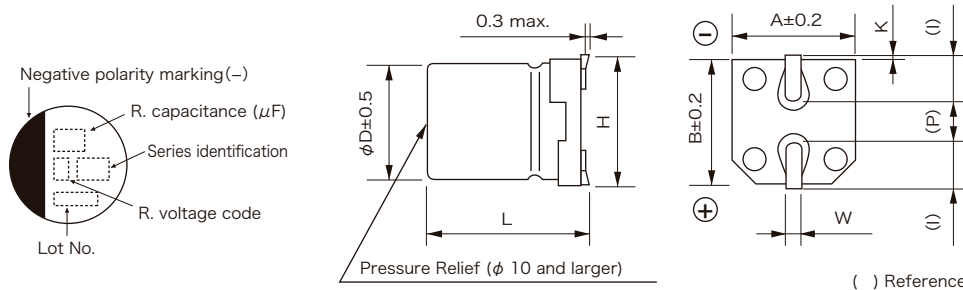

(Unit : mm)

R. voltage (V)	25	35	50	63
Code	E	V	H	J

Size code	φD	L	A,B	H	I	W	P	K
F	8.0	10.2±0.3	8.3	10.0 max.	3.4	0.90±0.2	3.1	0.70±0.2
G	10.0	10.2±0.3	10.3	12.0 max.	3.5	0.90±0.2	4.6	0.70±0.2

※The dimensions of the vibration-proof products, please refer to the page of the mounting specification

Characteristics list

Endurance : 150 °C 1000 h

Series	Rated voltage (V)	Capacitance (±20%) (μF)	Case size (mm)			Size code	Specifications			Part number		Min. Packaging Qty (pcs)
			φD	L			Ripple Current ※1 (mA rms)	ESR ※2 (mΩ)	tan δ ※3	Standard product	Vibration-proof product	
				Standard product	Vibration-proof product							Taping
ZF	25	150	8.0	10.2	10.5	F	800	27	0.14	EEHZF1E151P	EEHZF1E151V	500
		270	10.0	10.2	10.5	G	1000	20	0.14	EEHZF1E271P	EEHZF1E271V	500
	35	100	8.0	10.2	10.5	F	770	30	0.12	EEHZF1V101P	EEHZF1V101V	500
		150	10.0	10.2	10.5	G	950	23	0.12	EEHZF1V151P	EEHZF1V151V	500
	50	56	8.0	10.2	10.5	F	700	35	0.10	EEHZF1H560P	EEHZF1H560V	500
		100	10.0	10.2	10.5	G	900	28	0.10	EEHZF1H101P	EEHZF1H101V	500
	63	33	8.0	10.2	10.5	F	650	40	0.08	EEHZF1J330P	EEHZF1J330V	500
		56	10.0	10.2	10.5	G	840	30	0.08	EEHZF1J560P	EEHZF1J560V	500

※1: Ripple current (100 kHz/ +150 °C)

※2: ESR (100 kHz/+20 °C)

※3: tan δ (120 Hz/ +20 °C)

◆Please refer to the P127 to 129 in this catalog for "Reflow conditions" and "Taping specifications".

Frequency correction factor for ripple current

Rated capacitance (C)	Frequency	100 Hz ≤ f < 200 Hz	200 Hz ≤ f < 300 Hz	300 Hz ≤ f < 500 Hz	500 Hz ≤ f < 1 kHz
C < 47 μF	Correction factor	0.10	0.10	0.15	0.20
47 μF ≤ C < 150 μF		0.15	0.20	0.25	0.30
150 μF ≤ C		0.15	0.25	0.25	0.30

Rated capacitance (C)	Frequency	1 kHz ≤ f < 2 kHz	2 kHz ≤ f < 3 kHz	3 kHz ≤ f < 5 kHz	5 kHz ≤ f < 10 kHz
C < 47 μF	Correction factor	0.30	0.40	0.45	0.50
47 μF ≤ C < 150 μF		0.40	0.45	0.55	0.60
150 μF ≤ C		0.45	0.50	0.60	0.65

Rated capacitance (C)	Frequency	10 kHz ≤ f < 15 kHz	15 kHz ≤ f < 20 kHz	20 kHz ≤ f < 30 kHz	30 kHz ≤ f < 40 kHz
C < 47 μF	Correction factor	0.60	0.65	0.70	0.75
47 μF ≤ C < 150 μF		0.70	0.75	0.80	0.80
150 μF ≤ C		0.75	0.80	0.85	0.85

Rated capacitance (C)	Frequency	40 kHz ≤ f < 50 kHz	50 kHz ≤ f < 100 kHz	100 kHz ≤ f < 500 kHz	500 kHz ≤ f
C < 47 μF	Correction factor	0.80	0.85	1.00	1.05
47 μF ≤ C < 150 μF		0.85	0.90	1.00	1.00
150 μF ≤ C		0.85	0.90	1.00	1.00

Design and Specifications are each subject to change without notice. Ask factory for the current technical Specifications before purchase and/or use. Should a safety concern arise regarding this product, please be sure to contact us immediately.

SP-Cap

Guidelines and Precautions
Mounting specifications
Packing specifications

Selection guide

Surface mount type

Catalog EOL models

POSCAP

Guidelines and Precautions
Mounting specifications
Packing specifications

Selection guide

Surface mount type

Catalog Deletion models

Catalog EOL models

OS-CON

Guidelines and Precautions
Mounting specifications
Packing specifications

Selection guide

Surface mount type

Radial lead type

Catalog EOL models

Hybrid

Guidelines and Precautions
Mounting specifications
Packing specifications

Line-up

Series system diagram

Products list

ZA
ZC
ZK
ZKU
ZT
ZS
ZSU
ZU
ZE
ZF
ZA-A
ZC-A
ZK-A
ZKU-A
ZT-A
ZS-A
ZSU-A
ZE-A
ZF-A

Design and specifications are each subject to change without notice. Ask factory for the current technical specifications before purchase and/or use. Should a safety concern arise regarding this product, please be sure to contact us immediately.



Endurance : 10000 h at 105 °C (105 °C standard product)

Taping products for automatic insertion

AEC-Q200 compliant

RoHS compliant

SP-Cap

Guidelines and Precautions
Mounting specifications
Packing specifications

Selection guide

Surface mount type

Catalog EOL models

POSCAP

Guidelines and Precautions
Mounting specifications
Packing specifications

Selection guide

Surface mount type

Catalog Deletion models

Catalog EOL models

OS-CON

Guidelines and Precautions
Mounting specifications
Packing specifications

Selection guide

Surface mount type

Radial lead type

Catalog EOL models

Hybrid

Guidelines and Precautions
Mounting specifications
Packing specifications

Line-up

Series system diagram

Products list

- ZA
- ZC
- ZK
- ZKU
- ZT
- ZS
- ZSU
- ZU
- ZE
- ZF

Surface mount type

ZA-A

- ZC-A
- ZK-A
- ZKU-A
- ZT-A
- ZS-A
- ZSU-A
- ZE-A
- ZF-A

Radial lead type

Specifications

Items	Specifications	
Size code	F	G
Category temperature range	-55 °C to +105 °C	
Rated voltage range	25 V to 80 V	
Nominal capacitance range	22 μF to 220 μF	33 μF to 330 μF
Capacitance tolerance	±20 % (120 Hz/+20 °C)	
DC leakage current	I ≤ 0.01 CV (μA), 2 minutes after reaching rated voltage, 20 °C *CV = (Capacitance in μF) x (Rated voltage in V)	
Dissipation factor (tan δ)	Please see the attached characteristics list	
Surge voltage (V)	Rated voltage x 1.25 (15 °C to 35 °C)	
Endurance	+105 °C±2 °C, 10000 h, apply the rated ripple current without exceeding the rated voltage.	
	Capacitance change	Within ±30% of the initial value
	Dissipation factor (tan δ)	≤ 200 % of the initial limit
	E.S.R.	≤ 200 % of the initial limit
	Leakage current	Within the initial limit
ESR after endurance (Ω / 100 kHz) (-40 °C)	Size code	
	F	G
	0.4	0.3
Shelf life	After storage for 1000 hours at +105 °C±2 °C with no voltage applied and then being stabilized at +20°C, capacitors shall meet the limits specified in endurance. (With voltage treatment)	
Damp heat (Load)	+85 °C±2 °C, 85 % to 90 % RH, 2000 h, rated voltage applied.	
	Capacitance change	Within ±30% of the initial value
	Dissipation factor (tan δ)	≤ 200 % of the initial limit
	E.S.R.	≤ 200 % of the initial limit
Leakage current	Within the initial limit	
Resistance to soldering heat	After flow soldering and then being stabilized at +20°C, capacitors shall meet the following limits.	
	Capacitance change	Within ±10% of the initial value
	Dissipation factor (tan δ)	Within the initial limit
Leakage current	Within the initial limit	

Marking and Dimensions

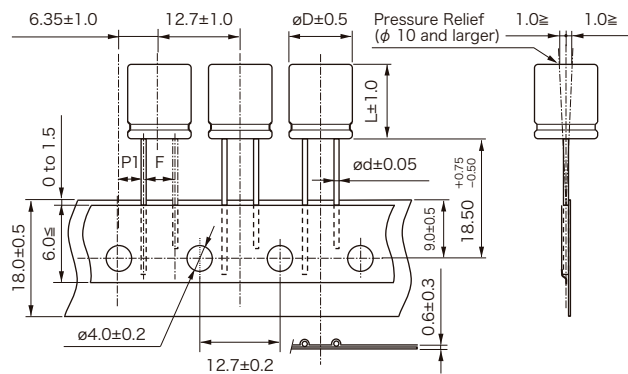
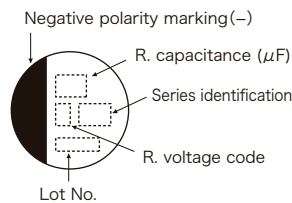

(Unit : mm)

R. voltage (V)	25	35	50	63	80
Code	E	V	H	J	K

Size code	φD	L	φd	F	P1
F	8.0	9.5	0.6	3.5±0.5	4.60±0.50
G	10.0	9.5	0.6	5.0 ^{+0.8} _{-0.2}	3.85±0.50

Characteristics list

Endurance : 105 °C 10000 h

Series	Rated voltage (V)	Capacitance (+20 %) (μF)	Case size (mm)			Size code	Specifications			Part number	Min. Packaging Qty (pcs)	
			φD	L	φd		Ripple Current ※1 (mA rms)	ESR ※2 (mΩ)	tan δ ※3		Taping	
ZA-A	25	150	8.0	9.5	0.6	F	2300	27	0.14	EEHAZA1E151B	1000	
		220	8.0	9.5	0.6		2300	27	0.14	EEHAZA1E221B	1000	
		330	10.0	9.5	0.6	G	2500	20	0.14	EEHAZA1E331B	500	
	35	100	8.0	9.5	0.6	F	2300	27	0.12	EEHAZA1V101B	1000	
		150	8.0	9.5	0.6		2300	27	0.12	EEHAZA1V151B	1000	
		220	10.0	9.5	0.6	G	2500	20	0.12	EEHAZA1V221B	500	
	270	10.0	9.5	0.6	2500		20	0.12	EEHAZA1V271B	500		
	50	47	8.0	9.5	0.6	F	1800	30	0.10	EEHAZA1H470B	1000	
		68	8.0	9.5	0.6		1800	30	0.10	EEHAZA1H680B	1000	
		100	10.0	9.5	0.6	G	2000	28	0.10	EEHAZA1H101B	500	
	63	33	8.0	9.5	0.6	F	1700	40	0.08	EEHAZA1J330B	1000	
		47	8.0	9.5	0.6		1700	40	0.08	EEHAZA1J470B	1000	
		56	10.0	9.5	0.6	G	1800	30	0.08	EEHAZA1J560B	500	
		68	10.0	9.5	0.6		1800	30	0.08	EEHAZA1J680B	500	
		82	10.0	9.5	0.6		1800	30	0.08	EEHAZA1J820B	500	
	80	22	8.0	9.5	0.6	F	1550	45	0.08	EEHAZA1K220B	1000	
		33	10.0	9.5	0.6	G	1700	36	0.08	EEHAZA1K330B	500	
		47	10.0	9.5	0.6		1700	36	0.08	EEHAZA1K470B	500	

※1: Ripple current (100 kHz/ +105 °C)

※2: ESR (100 kHz/+20 °C)

※3: tan δ (120 Hz/ +20 °C)

◆Please refer to the P127 to 129 in this catalog for "Reflow conditions" and "Taping specifications".

Frequency correction factor for ripple current

Rated capacitance(C)	Frequency	100 Hz ≤ f < 200 Hz	200 Hz ≤ f < 300 Hz	300 Hz ≤ f < 500 Hz	500 Hz ≤ f < 1 kHz
C < 47 μF	Correction factor	0.10	0.10	0.15	0.20
47 μF ≤ C < 150 μF		0.15	0.20	0.25	0.30
150 μF ≤ C		0.15	0.25	0.25	0.30

Rated capacitance(C)	Frequency	1 kHz ≤ f < 2 kHz	2 kHz ≤ f < 3 kHz	3 kHz ≤ f < 5 kHz	5 kHz ≤ f < 10 kHz
C < 47 μF	Correction factor	0.30	0.40	0.45	0.50
47 μF ≤ C < 150 μF		0.40	0.45	0.55	0.60
150 μF ≤ C		0.45	0.50	0.60	0.65

Rated capacitance(C)	Frequency	10 kHz ≤ f < 15 kHz	15 kHz ≤ f < 20 kHz	20 kHz ≤ f < 30 kHz	30 kHz ≤ f < 40 kHz
C < 47 μF	Correction factor	0.60	0.65	0.70	0.75
47 μF ≤ C < 150 μF		0.70	0.75	0.80	0.80
150 μF ≤ C		0.75	0.80	0.85	0.85

Rated capacitance(C)	Frequency	40 kHz ≤ f < 50 kHz	50 kHz ≤ f < 100 kHz	100 kHz ≤ f < 500 kHz	500 kHz ≤ f
C < 47 μF	Correction factor	0.80	0.85	1.00	1.05
47 μF ≤ C < 150 μF		0.85	0.90	1.00	1.00
150 μF ≤ C		0.85	0.90	1.00	1.00

SP-Cap

Guidelines and Precautions
Mounting specifications
Packaging specifications

Selection guide

Surface mount type

Catalog EOL models

POSCAP

Guidelines and Precautions
Mounting specifications
Packaging specifications

Selection guide

Surface mount type

Catalog Deletion models

Catalog EOL models

OS-CON

Guidelines and Precautions
Mounting specifications
Packaging specifications

Selection guide

Surface mount type

Radial lead type

Catalog EOL models

Hybrid

Guidelines and Precautions
Mounting specifications
Packaging specifications

Line-up
Series system diagram
Products list

ZA
ZC
ZK
ZKU
ZT
ZS
ZSU
ZU
ZE
ZF

ZA-A
ZC-A
ZK-A
ZKU-A
ZT-A
ZS-A
ZSU-A
ZE-A
ZF-A



Endurance : 4000 h at 125 °C (125 °C standard product)

Taping products for automatic insertion

AEC-Q200 compliant

RoHS compliant

SP-Cap

Guidelines and Precautions
Mounting specifications
Packing specifications

Selection guide

Surface mount type

Catalog EOL models

POSCAP

Guidelines and Precautions
Mounting specifications
Packing specifications

Selection guide

Surface mount type

Catalog Deletion models

Catalog EOL models

OS-CON

Guidelines and Precautions
Mounting specifications
Packing specifications

Selection guide

Surface mount type

Radial lead type

Catalog EOL models

Hybrid

Guidelines and Precautions
Mounting specifications
Packing specifications

Line-up
Series system diagram
Products list

- ZA
- ZC
- ZK
- ZKU
- ZT
- ZS
- ZSU
- ZU
- ZE
- ZF
- ZA-A
- ZC-A**
- ZK-A
- ZKU-A
- ZT-A
- ZS-A
- ZSU-A
- ZE-A
- ZF-A

Surface mount type

Radial lead type

Specifications

Items	Specifications	
Size code	F	G
Category temperature range	-55 °C to +125 °C	
Rated voltage range	25 V to 80 V	
Nominal capacitance range	22 μF to 220 μF	33 μF to 330 μF
Capacitance tolerance	±20 % (120 Hz/+20 °C)	
Leakage current	I ≤ 0.01 CV (μA), 2 minutes after reaching rated voltage, 20 °C *CV = (Capacitance in μF) x (Rated voltage in V)	
Dissipation factor(tanδ)	Please see the attached characteristics list	
Surge voltage(V)	Rated voltage × 1.25 (15 °C to 35 °C)	
Endurance 1	+125 °C±2 °C, 4000 h, apply the rated ripple current without exceeding the rated voltage.	
	Capacitance change	Within ±30% of the initial value
	tan δ	≤ 200 % of the initial limit
	E.S.R.	≤ 200 % of the initial limit
Endurance 2	+125 °C±2 °C, 3000 h, apply the rated ripple current without exceeding the rated voltage.	
	Capacitance change	Within ±30% of the initial value
	tan δ	≤ 200 % of the initial limit
	E.S.R.	≤ 300 % of the initial limit
Shelf life	After storage for 1000 hours at +125 °C±2 °C with no voltage applied and then being stabilized at +20 °C, capacitors shall meet the limits specified in endurance. (With voltage treatment)	
	+85 °C±2 °C, 85 % to 90 % RH, 2000 h, rated voltage applied.	
	Capacitance change	Within ±30% of the initial value
	tan δ	≤ 200 % of the initial limit
Damp heat (Load)	After storage for 1000 hours at +125 °C±2 °C with no voltage applied and then being stabilized at +20 °C, capacitors shall meet the limits specified in endurance. (With voltage treatment)	
	+85 °C±2 °C, 85 % to 90 % RH, 2000 h, rated voltage applied.	
	Capacitance change	Within ±30% of the initial value
	tan δ	≤ 200 % of the initial limit
Resistance to soldering heat	After flow soldering and then being stabilized at +20 °C, capacitors shall meet the following limits.	
	Capacitance change	Within ±10% of the initial value
	tanδ	Within the initial limit
	Leakage current	Within the initial limit

Marking and Dimensions

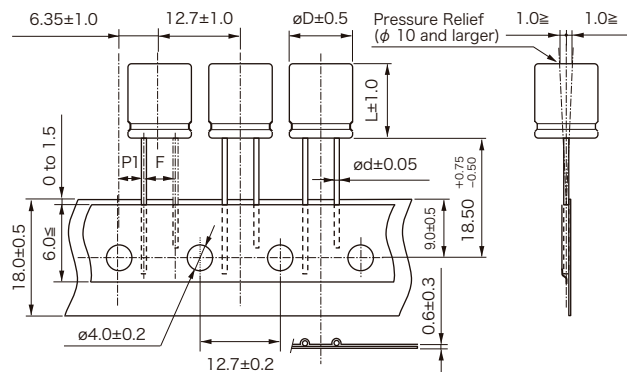
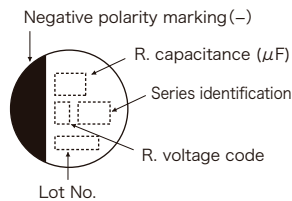

(Unit : mm)

R. voltage (V)	25	35	50	63	80
Code	E	V	H	J	K

Size code	φD	L	φd	F	P1
F	8.0	9.5	0.6	3.5±0.5	4.60±0.50
G	10.0	9.5	0.6	5.0 ^{+0.8} _{-0.2}	3.85±0.50

Characteristics list

Endurance 1: 125 °C 4000 h
Endurance 2: 125 °C 3000 h

Series	Rated voltage (V)	Capacitance (±20%) (μF)	Case size (mm)			Size code	Specifications				Part number	Min. Packaging Qty (pcs)
			φD	L	φd		Ripple Current ※1 (mA rms)		ESR ※2 (mΩ)	tan δ ※3		Taping
							Endurance 1	Endurance 2				
ZC-A	25	150	8.0	9.5	0.6	F	1600	1900	27	0.14	EEHAZC1E151B	1000
		220	8.0	9.5	0.6		1600	1900	27	0.14	EEHAZC1E221B	1000
		330	10.0	9.5	0.6	G	2000	2900	20	0.14	EEHAZC1E331B	500
	35	100	8.0	9.5	0.6	F	1600	1900	27	0.12	EEHAZC1V101B	1000
		150	8.0	9.5	0.6		1600	1900	27	0.12	EEHAZC1V151B	1000
		220	10.0	9.5	0.6	G	2000	2800	20	0.12	EEHAZC1V221B	500
	270	10.0	9.5	0.6	2000		2800	20	0.12	EEHAZC1V271B	500	
	50	47	8.0	9.5	0.6	F	1250	-	30	0.10	EEHAZC1H470B	1000
		68	8.0	9.5	0.6		1250	-	30	0.10	EEHAZC1H680B	1000
		100	10.0	9.5	0.6	G	1600	-	28	0.10	EEHAZC1H101B	500
		120	10.0	9.5	0.6		1600	-	28	0.10	EEHAZC1H121B	500
	63	33	8.0	9.5	0.6	F	1100	-	40	0.08	EEHAZC1J330B	1000
		47	8.0	9.5	0.6		1100	-	40	0.08	EEHAZC1J470B	1000
		56	10.0	9.5	0.6	G	1400	-	30	0.08	EEHAZC1J560B	500
		68	10.0	9.5	0.6		1400	-	30	0.08	EEHAZC1J680B	500
		82	10.0	9.5	0.6		1400	-	30	0.08	EEHAZC1J820B	500
	80	22	8.0	9.5	0.6	F	1050	-	45	0.08	EEHAZC1K220B	1000
		33	10.0	9.5	0.6	G	1360	-	36	0.08	EEHAZC1K330B	500
		47	10.0	9.5	0.6		1360	-	36	0.08	EEHAZC1K470B	500

※1: Ripple current (100 kHz/ +125 °C)

※2: ESR (100 kHz/+20 °C)

※3: tan δ (120 Hz/ +20 °C)

◆Please refer to the P127 to 129 in this catalog for "Reflow conditions" and "Taping specifications".

Frequency correction factor for ripple current

Rated capacitance (C)	Frequency	100 Hz ≤ f < 200 Hz	200 Hz ≤ f < 300 Hz	300 Hz ≤ f < 500 Hz	500 Hz ≤ f < 1 kHz
C < 47 μF	Correction factor	0.10	0.10	0.15	0.20
47 μF ≤ C < 150 μF		0.15	0.20	0.25	0.30
150 μF ≤ C		0.15	0.25	0.25	0.30

Rated capacitance (C)	Frequency	1 kHz ≤ f < 2 kHz	2 kHz ≤ f < 3 kHz	3 kHz ≤ f < 5 kHz	5 kHz ≤ f < 10 kHz
C < 47 μF	Correction factor	0.30	0.40	0.45	0.50
47 μF ≤ C < 150 μF		0.40	0.45	0.55	0.60
150 μF ≤ C		0.45	0.50	0.60	0.65

Rated capacitance (C)	Frequency	10 kHz ≤ f < 15 kHz	15 kHz ≤ f < 20 kHz	20 kHz ≤ f < 30 kHz	30 kHz ≤ f < 40 kHz
C < 47 μF	Correction factor	0.60	0.65	0.70	0.75
47 μF ≤ C < 150 μF		0.70	0.75	0.80	0.80
150 μF ≤ C		0.75	0.80	0.85	0.85

Rated capacitance (C)	Frequency	40 kHz ≤ f < 50 kHz	50 kHz ≤ f < 100 kHz	100 kHz ≤ f < 500 kHz	500 kHz ≤ f < 1000 kHz
C < 47 μF	Correction factor	0.80	0.85	1.00	1.05
47 μF ≤ C < 150 μF		0.85	0.90	1.00	1.00
150 μF ≤ C		0.85	0.90	1.00	1.00

After endurance ESR (100 kHz, -40 °C)

Size code	F	G
ESR (Ω)	0.4	0.3

SP-Cap

Guidelines and Precaution
Mounting specifications
Packing specifications

Selection guide

Surface mount type

Catalog EOL models

POSCAP

Guidelines and Precautions
Mounting specifications
Packing specifications

Selection guide

Surface mount type

Catalog Deletion models

Catalog EOL models

OS-CON

Guidelines and Precautions
Mounting specifications
Packing specifications

Selection guide

Surface mount type

Radial lead type

Catalog EOL models

Hybrid

Guidelines and Precautions
Mounting specifications
Packing specifications

Selection guide | Series system diagram
Products list

ZA
ZC
ZK
ZKU
ZT
ZS
ZSU
ZU
ZE
ZF
ZC-A
ZK-A
ZKU-A
ZT-A
ZS-A
ZSU-A
ZE-A
ZF-A



Endurance : 4000 h at 125 °C (Large capacitance / High ripple current)

Taping products for automatic insertion

AEC-Q200 compliant

RoHS compliant

SP-Cap

Guidelines and Precautions
Mounting specifications
Packing specifications

Selection guide

Surface mount type

Catalog EOL models

POSCAP

Guidelines and Precautions
Mounting specifications
Packing specifications

Selection guide

Surface mount type

Catalog Deletion models

Catalog EOL models

OS-CON

Guidelines and Precautions
Mounting specifications
Packing specifications

Selection guide

Surface mount type

Radial lead type

Catalog EOL models

Hybrid

Guidelines and Precautions
Mounting specifications
Packing specifications

Line-up

Series system diagram

Products list

- ZA
- ZC
- ZK
- ZKU
- ZT
- ZS
- ZSU
- ZU
- ZE
- ZF
- ZA-A
- ZC-A
- ZK-A**
- ZKU-A
- ZT-A
- ZS-A
- ZSU-A
- ZE-A
- ZF-A

Surface mount type
Radial lead type

Specifications

Items	Specifications	
Size code	F	G
Category temperature range	-55 °C to +125 °C	
Rated voltage range	25 V to 35 V	
Nominal capacitance range	180 μF to 270 μF	330 μF to 470 μF
Capacitance tolerance	±20 % (120 Hz/+20 °C)	
DC leakage current	I ≤ 0.01 CV (μA), 2 minutes after reaching rated voltage, 20 °C *CV = (Capacitance in μF) x (Rated voltage in V)	
Dissipation factor (tan δ)	Please see the attached characteristics list	
Surge voltage (V)	Rated voltage x 1.25 (15 °C to 35 °C)	
Endurance	+125 °C±2 °C, 4000 h, apply the rated ripple current without exceeding the rated voltage.	
	Capacitance change	Within ±30% of the initial value
	Dissipation factor (tan δ)	≤ 200 % of the initial limit
	E.S.R.	≤ 200 % of the initial limit
	Leakage current	Within the initial limit
ESR after endurance (Ω / 100 kHz) (-40 °C)	Size code	
	F	G
	0.4	0.3
Shelf life	After storage for 1000 hours at +125 °C±2 °C with no voltage applied and then being stabilized at +20°C, capacitors shall meet the limits specified in endurance. (With voltage treatment)	
Damp heat (Load)	+85 °C ± 2 °C, 85 % to 90 % RH, 2000 h, rated voltage applied	
	Capacitance change	Within ±30% of the initial value
	Dissipation factor (tan δ)	≤ 200 % of the initial limit
	E.S.R.	≤ 200 % of the initial limit
Leakage current	Within the initial limit	
Resistance to soldering heat	After flow soldering and then being stabilized at +20°C, capacitors shall meet the following limits.	
	Capacitance change	Within ±10% of the initial value
	Dissipation factor (tan δ)	Within the initial limit
Leakage current	Within the initial limit	

Marking and Dimensions

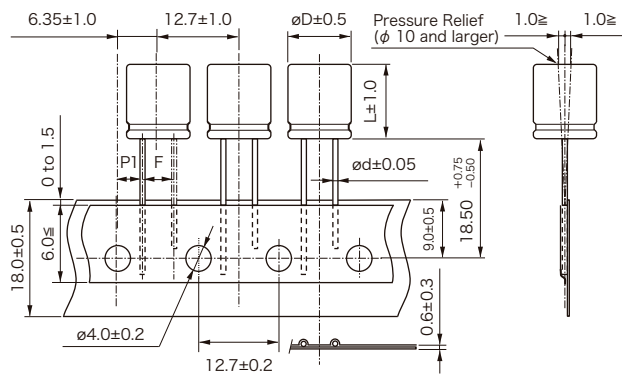
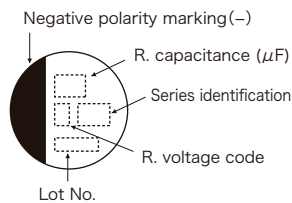

(Unit : mm)

R. voltage (V)	25	35
Code	E	V

Size code	φD	L	φd	F	P1
F	8.0	9.5	0.6	3.5±0.5	4.60±0.50
G	10.0	9.5	0.6	5.0 ^{+0.8} _{-0.2}	3.85±0.50

Characteristics list

Endurance : 125 °C 4000 h

Series	Rated voltage (V)	Capacitance (+20 %) (μF)	Case size (mm)			Size code	Specifications			Part number	Min. Packaging Qty (pcs)
			φD	L	φd		Ripple Current ※1 (mA rms)	ESR ※2 (mΩ)	tan δ ※3		Taping
ZK-A	25	270	8.0	9.5	0.6	F	2000	27	0.14	EEHAZK1E271B	1000
		470	10.0	9.5	0.6	G	2800	20	0.14	EEHAZK1E471B	500
	35	180	8.0	9.5	0.6	F	2000	27	0.12	EEHAZK1V181B	1000
		330	10.0	9.5	0.6	G	2800	20	0.12	EEHAZK1V331B	500

※1: Ripple current (100 kHz/ +125 °C)

※2: ESR (100 kHz/+20 °C)

※3: tan δ (120 Hz/ +20 °C)

◆Please refer to the P127 to 129 in this catalog for "Reflow conditions" and "Taping specifications".

Frequency correction factor for ripple current

Frequency (f)	100 Hz ≤ f < 120 Hz	120 Hz ≤ f < 200 Hz	200 Hz ≤ f < 300 Hz	300 Hz ≤ f < 500 Hz
Correction factor	0.15	0.20	0.25	0.30

Frequency (f)	500 Hz ≤ f < 1 kHz	1 kHz ≤ f < 2 kHz	2 kHz ≤ f < 3 kHz	3 kHz ≤ f < 5 kHz
Correction factor	0.40	0.50	0.60	0.65

Frequency (f)	5 kHz ≤ f < 10 kHz	10 kHz ≤ f < 15 kHz	15 kHz ≤ f < 20 kHz	20 kHz ≤ f < 30 kHz
Correction factor	0.70	0.75	0.80	0.85

Frequency (f)	30 kHz ≤ f < 40 kHz	40 kHz ≤ f < 50 kHz	50 kHz ≤ f < 100 kHz	100 kHz ≤ f < 1000 kHz
Correction factor	0.85	0.85	0.90	1.00

SP-Cap

Guidelines and Precautions
Mounting specifications
Packing specifications

Selection guide

Surface mount type

Catalog EOL models

POSCAP

Guidelines and Precautions
Mounting specifications
Packing specifications

Selection guide

Surface mount type

Catalog Deletion models

Catalog EOL models

OS-CON

Guidelines and Precautions
Mounting specifications
Packing specifications

Selection guide

Surface mount type

Radial lead type

Catalog EOL models

Hybrid

Guidelines and Precautions
Mounting specifications
Packing specifications

Selection guide	Line-up
	Series system diagram
Surface mount type	Products list
	ZA
	ZC
	ZK
	ZKU
	ZT
	ZS
	ZSU
	ZU
	ZE
	ZF
	ZA-A
	ZC-A
ZK-A	
ZKU-A	
ZT-A	
ZS-A	
ZSU-A	
ZE-A	
ZF-A	



Endurance : 4000 h at 125 °C (Large capacitance / High ripple current)

Taping products for automatic insertion

AEC-Q200 compliant

RoHS compliant

SP-Cap

Guidelines and Precautions
Mounting specifications
Packing specifications

Selection guide

Surface mount type

POSCAP

Guidelines and Precautions
Mounting specifications
Packing specifications

Selection guide

Surface mount type

Catalog Deletion models
Catalog EOL models

OS-CON

Guidelines and Precautions
Mounting specifications
Packing specifications

Selection guide

Surface mount type

Radial lead type

Catalog EOL models

Hybrid

Guidelines and Precautions
Mounting specifications
Packing specifications

Line-up
Series system diagram
Products list

Selection guide

Surface mount type

Radial lead type

Specifications

Items	Specifications	
Size code	F	G
Category temperature range	-55 °C to +125 °C	
Rated voltage range	25 V to 35 V	
Nominal capacitance range	220 μ F to 330 μ F	390 μ F to 560 μ F
Capacitance tolerance	$\pm 20\%$ (120 Hz/+20 °C)	
DC leakage current	$I \leq 0.01 CV$ (μ A), 2 minutes after reaching rated voltage, 20 °C *CV = (Capacitance in μ F) x (Rated voltage in V)	
Dissipation factor (tan δ)	Please see the attached characteristics list	
Surge voltage (V)	Rated voltage x 1.25 (15 °C to 35 °C)	
Endurance	+125 °C \pm 2 °C, 4000 h, apply the rated ripple current without exceeding the rated voltage.	
	Capacitance change	Within $\pm 30\%$ of the initial value
	Dissipation factor (tan δ)	$\leq 200\%$ of the initial limit
	E.S.R.	$\leq 200\%$ of the initial limit
	Leakage current	Within the initial limit
ESR after endurance (Ω / 100 kHz) (-40 °C)	Size code	
	F	G
	0.4	0.3
Shelf life	After storage for 1000 hours at +125 °C \pm 2 °C with no voltage applied and then being stabilized at +20°C, capacitors shall meet the limits specified in endurance. (With voltage treatment)	
Damp heat (Load)	+85 °C \pm 2 °C, 85 % to 90 % RH, 2000 h, rated voltage applied	
	Capacitance change	Within $\pm 30\%$ of the initial value
	Dissipation factor (tan δ)	$\leq 200\%$ of the initial limit
	E.S.R.	$\leq 200\%$ of the initial limit
Leakage current	Within the initial limit	
Resistance to soldering heat	After flow soldering and then being stabilized at +20°C, capacitors shall meet the following limits.	
	Capacitance change	Within $\pm 10\%$ of the initial value
	Dissipation factor (tan δ)	Within the initial limit
Leakage current	Within the initial limit	

Marking and Dimensions

(Unit : mm)

R. voltage (V)	25	35
Code	E	V

Size code	ϕ D	L	ϕ d	F	P1
F	8.0	9.5	0.6	3.5 \pm 0.5	4.60 \pm 0.50
G	10.0	9.5	0.6	5.0 ^{+0.8} _{-0.2}	3.85 \pm 0.50

Characteristics list

Endurance : 125 °C 4000 h

Series	Rated voltage (V)	Capacitance (+20 %) (μF)	Case size (mm)			Size code	Specifications			Part number	Min. Packaging Qty (pcs)
			φD	L	φd		Ripple Current ※1 (mA rms)	ESR ※2 (mΩ)	tan δ ※3		Taping
ZKU-A	25	330	8.0	9.5	0.6	F	2000	27	0.14	EEHAZKE331UB	1000
		560	10.0	9.5	0.6	G	2800	20	0.14	EEHAZKE561UB	500
	35	220	8.0	9.5	0.6	F	2000	27	0.12	EEHAZKV221UB	1000
		390	10.0	9.5	0.6	G	2800	20	0.12	EEHAZKV391UB	500

※1: Ripple current (100 kHz/ +125 °C)

※2: ESR (100 kHz/+20 °C)

※3: tan δ (120 Hz/ +20 °C)

◆Please refer to the P127 to 129 in this catalog for "Reflow conditions" and "Taping specifications".

Frequency correction factor for ripple current

Frequency (f)	100 Hz ≤ f < 120 Hz	120 Hz ≤ f < 200 Hz	200 Hz ≤ f < 300 Hz	300 Hz ≤ f < 500 Hz
Correction factor	0.15	0.20	0.25	0.30

Frequency (f)	500 Hz ≤ f < 1 kHz	1 kHz ≤ f < 2 kHz	2 kHz ≤ f < 3 kHz	3 kHz ≤ f < 5 kHz
Correction factor	0.40	0.50	0.60	0.65

Frequency (f)	5 kHz ≤ f < 10 kHz	10 kHz ≤ f < 15 kHz	15 kHz ≤ f < 20 kHz	20 kHz ≤ f < 30 kHz
Correction factor	0.70	0.75	0.80	0.85

Frequency (f)	30 kHz ≤ f < 40 kHz	40 kHz ≤ f < 50 kHz	50 kHz ≤ f < 100 kHz	100 kHz ≤ f < 1000 kHz
Correction factor	0.85	0.85	0.90	1.00

SP-Cap

Guidelines and Precautions
Mounting specifications
Packing specifications

Selection guide

Surface mount type

Catalog EOL models

POSCAP

Guidelines and Precautions
Mounting specifications
Packing specifications

Selection guide

Surface mount type

Catalog Deletion models

Catalog EOL models

OS-CON

Guidelines and Precautions
Mounting specifications
Packing specifications

Selection guide

Surface mount type

Radial lead type

Catalog EOL models

Hybrid

Guidelines and Precautions
Mounting specifications
Packing specifications

Selection guide

Series system diagram	Line-up
	Products list
Surface mount type	ZA
	ZC
	ZK
	ZKU
	ZT
	ZS
	ZSU
	ZU
	ZE
	ZF
	ZA-A
	ZC-A
	ZK-A
Radial lead type	ZKU-A
	ZT-A
	ZS-A
	ZSU-A
	ZF-A



Endurance : 4000 h at 125 °C (High ripple current)

Taping products for automatic insertion

AEC-Q200 compliant

RoHS compliant

SP-Cap

Guidelines and Precautions
Mounting specifications
Packing specifications

Selection guide

Surface mount type

POSCAP

Guidelines and Precautions
Mounting specifications
Packing specifications

Selection guide

Surface mount type

Catalog Deletion models
Catalog EOL models

OS-CON

Guidelines and Precautions
Mounting specifications
Packing specifications

Selection guide

Surface mount type

Radial lead type

Hybrid

Guidelines and Precautions
Mounting specifications
Packing specifications

Line-up

Series system diagram

Products list

- ZA
- ZC
- ZK
- ZKU
- ZT**
- ZS
- ZSU
- ZU
- ZE
- ZF
- ZA-A
- ZC-A
- ZK-A
- ZKU-A
- ZT-A**
- ZS-A
- ZSU-A
- ZE-A
- ZF-A

Surface mount type
Radial lead type

Specifications

Items	Specifications	
Size code	F	G
Category temperature range	-55 °C to +125 °C	
Rated voltage range	25 V to 63 V	
Nominal capacitance range	33 μF to 220 μF	56 μF to 330 μF
Capacitance tolerance	±20 % (120 Hz/+20 °C)	
DC leakage current	I ≤ 0.01 CV (μA), 2 minutes after reaching rated voltage, 20 °C *CV = (Capacitance in μF) x (Rated voltage in V)	
Dissipation factor (tan δ)	Please see the attached characteristics list	
Surge voltage (V)	Rated voltage x 1.25 (15 °C to 35 °C)	
Endurance	+125 °C±2 °C, 4000 h, apply the rated ripple current without exceeding the rated voltage.	
	Capacitance change	Within ±30% of the initial value
	Dissipation factor (tan δ)	≤ 200 % of the initial limit
	E.S.R.	≤ 200 % of the initial limit
	Leakage current	Within the initial limit
ESR after endurance (Ω / 100 kHz) (-40 °C)	Size code	
	F	G
	0.4	0.3
Shelf life	After storage for 1000 hours at +125 °C±2 °C with no voltage applied and then being stabilized at +20°C, capacitors shall meet the limits specified in endurance. (With voltage treatment)	
Damp heat (Load)	+85 °C ± 2 °C, 85 % to 90 % RH, 2000 h, rated voltage applied	
	Capacitance change	Within ±30% of the initial value
	Dissipation factor (tan δ)	≤ 200 % of the initial limit
	E.S.R.	≤ 200 % of the initial limit
Leakage current	Within the initial limit	
Resistance to soldering heat	After flow soldering and then being stabilized at +20°C, capacitors shall meet the following limits.	
	Capacitance change	Within ±10% of the initial value
	Dissipation factor (tan δ)	Within the initial limit
Leakage current	Within the initial limit	

Marking and Dimensions

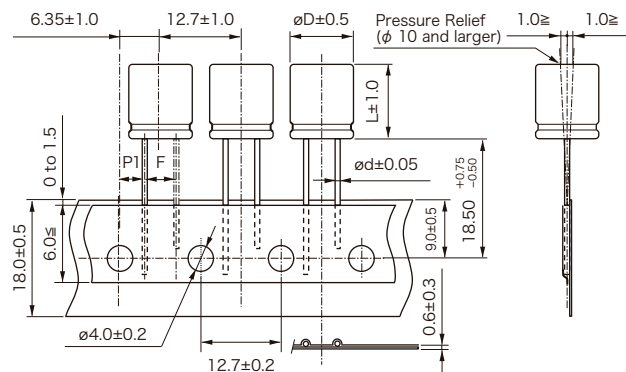
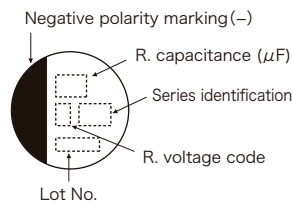

(Unit : mm)

R. voltage (V)	25	35	50	63
Code	E	V	H	J

Size code	φD	L	φd	F	P1
F	8.0	9.5	0.6	3.5±0.5	4.60±0.50
G	10.0	9.5	0.6	5.0 ^{+0.8} / _{-0.2}	3.85±0.50

Characteristics list

Endurance : 125 °C 4000 h

Series	Rated voltage (V)	Capacitance (±20%) (μF)	Case size (mm)			Size code	Specifications			Part number	Min. Packaging Qty (pcs)	
			φD	L	φd		Ripple Current ※1 (mA rms)	ESR ※2 (mΩ)	tan δ ※3		Taping	
ZT-A	25	220	8.0	9.5	0.6	F	2900	22	0.14	EEHAZT1E221B	1000	
		330	10.0	9.5	0.6	G	3500	16	0.14	EEHAZT1E331B	500	
	35	150	8.0	9.5	0.6	F	2900	22	0.12	EEHAZT1V151B	1000	
		270	10.0	9.5	0.6	G	3500	16	0.12	EEHAZT1V271B	500	
	50	68	8.0	9.5	0.6	F	2700	25	0.10	EEHAZT1H680B	1000	
		100	10.0	9.5	0.6	G	2900	23	0.10	EEHAZT1H101B	500	
		120	10.0	9.5	0.6		2900	23	0.10	EEHAZT1H121B	500	
	63	33	8.0	9.5	0.6	F	2400	32	0.08	EEHAZT1J330B	1000	
		47	8.0	9.5	0.6		2400	32	0.08	EEHAZT1J470B	1000	
		56	10.0	9.5	0.6	G	2800	25	0.08	EEHAZT1J560B	500	
		68	10.0	9.5	0.6		2800	25	0.08	EEHAZT1J680B	500	
		82	10.0	9.5	0.6		2800	25	0.08	EEHAZT1J820B	500	

※1: Ripple current (100 kHz/ +125 °C)

※2: ESR (100 kHz/+20 °C)

※3: tan δ (120 Hz/ +20 °C)

◆Please refer to the P127 to 129 in this catalog for "Reflow conditions" and "Taping specifications".

Frequency correction factor for ripple current

Rated capacitance (C)	Frequency	100 Hz ≤ f < 200 Hz	200 Hz ≤ f < 300 Hz	300 Hz ≤ f < 500 Hz	500 Hz ≤ f < 1 kHz
C < 47 μF	Correction factor	0.10	0.10	0.15	0.20
47 μF ≤ C < 150 μF		0.15	0.20	0.25	0.30
150 μF ≤ C		0.15	0.25	0.25	0.30

Rated capacitance (C)	Frequency	1 kHz ≤ f < 2 kHz	2 kHz ≤ f < 3 kHz	3 kHz ≤ f < 5 kHz	5 kHz ≤ f < 10 kHz
C < 47 μF	Correction factor	0.30	0.40	0.45	0.50
47 μF ≤ C < 150 μF		0.40	0.45	0.55	0.60
150 μF ≤ C		0.45	0.50	0.60	0.65

Rated capacitance (C)	Frequency	10 kHz ≤ f < 15 kHz	15 kHz ≤ f < 20 kHz	20 kHz ≤ f < 30 kHz	30 kHz ≤ f < 40 kHz
C < 47 μF	Correction factor	0.60	0.65	0.70	0.75
47 μF ≤ C < 150 μF		0.70	0.75	0.80	0.80
150 μF ≤ C		0.75	0.80	0.85	0.85

Rated capacitance (C)	Frequency	40 kHz ≤ f < 50 kHz	50 kHz ≤ f < 100 kHz	100 kHz ≤ f < 500 kHz	500 kHz ≤ f < 1000 kHz
C < 47 μF	Correction factor	0.80	0.85	1.00	1.05
47 μF ≤ C < 150 μF		0.85	0.90	1.00	1.00
150 μF ≤ C		0.85	0.90	1.00	1.00

SP-Cap

Guidelines and Precautions
Mounting specifications
Packing specifications

Selection guide

Surface mount type

Catalog EOL models

POSCAP

Guidelines and Precautions
Mounting specifications
Packing specifications

Selection guide

Surface mount type

Catalog Deletion models

Catalog EOL models

OS-CON

Guidelines and Precautions
Mounting specifications
Packing specifications

Selection guide

Surface mount type

Radial lead type

Catalog EOL models

Hybrid

Guidelines and Precautions
Mounting specifications
Packing specifications

Selection guide

Series system diagram

Products list

ZA
ZC
ZK
ZKU
ZT
ZS
ZSU
ZU
ZE
ZF
ZA-A
ZC-A
ZK-A
ZKU-A
ZT-A
ZS-A
ZSU-A
ZE-A
ZF-A



Endurance : 4000 h at 135 °C (Large capacitance / High ripple current / Low ESR)

Taping products for automatic insertion

AEC-Q200 compliant

RoHS compliant

SP-Cap

Guidelines and Precautions
Mounting specifications
Packing specifications

Selection guide

Surface mount type

Catalog EOL models

POSCAP

Guidelines and Precautions
Mounting specifications
Packing specifications

Selection guide

Surface mount type

Catalog Deletion models

Catalog EOL models

OS-CON

Guidelines and Precautions
Mounting specifications
Packing specifications

Selection guide

Surface mount type

Radial lead type

Catalog EOL models

Hybrid

Guidelines and Precautions
Mounting specifications
Packing specifications

Line-up

Series system diagram

Products list

- ZA
- ZC
- ZK
- ZKU
- ZT
- ZS
- ZSU
- ZU
- ZE
- ZF
- ZS-A
- ZSU-A
- ZE-A
- ZF-A

Surface mount type

Radial lead type

Specifications

Items	Specifications	
Size code	G12	G16
Category temperature range	-55 °C to +135 °C	
Rated voltage range	25 V to 63 V	
Nominal capacitance range	100 μF to 470 μF	150 μF to 560 μF
Capacitance tolerance	±20 % (120 Hz/+20 °C)	
DC leakage current	I ≤ 0.01 CV (μA), 2 minutes after reaching rated voltage, 20 °C *CV = (Capacitance in μF) x (Rated voltage in V)	
Dissipation factor (tan δ)	Please see the attached characteristics list	
Surge voltage (V)	Rated voltage x 1.25 (15 °C to 35 °C)	
Endurance 1	+125 °C±2 °C, 4000 h, apply the rated ripple current without exceeding the rated voltage.	
	Capacitance change	Within ±30% of the initial value
	Dissipation factor (tan δ)	≤ 200 % of the initial limit
	E.S.R.	≤ 200 % of the initial limit
Endurance 2	+135 °C±2 °C, 4000 h, apply the rated ripple current without exceeding the rated voltage.	
	Capacitance change	Within ±30% of the initial value
	Dissipation factor (tan δ)	≤ 200 % of the initial limit
	E.S.R.	≤ 200 % of the initial limit
Shelf life	After storage for 1000 hours at +135 °C±2 °C with no voltage applied and then being stabilized at +20°C, capacitors shall meet the limits specified in endurance. (With voltage treatment)	
Damp heat (Load)	+85 °C ± 2 °C, 85 % to 90 % RH, 2000 h, rated voltage applied	
	Capacitance change	Within ±30% of the initial value
	Dissipation factor (tan δ)	≤ 200 % of the initial limit
	E.S.R.	≤ 200 % of the initial limit
Resistance to soldering heat	After flow soldering and then being stabilized at +20°C, capacitors shall meet the following limits.	
	Capacitance change	Within ±10% of the initial value
	Dissipation factor (tan δ)	Within the initial limit
	Leakage current	Within the initial limit

Marking and Dimensions

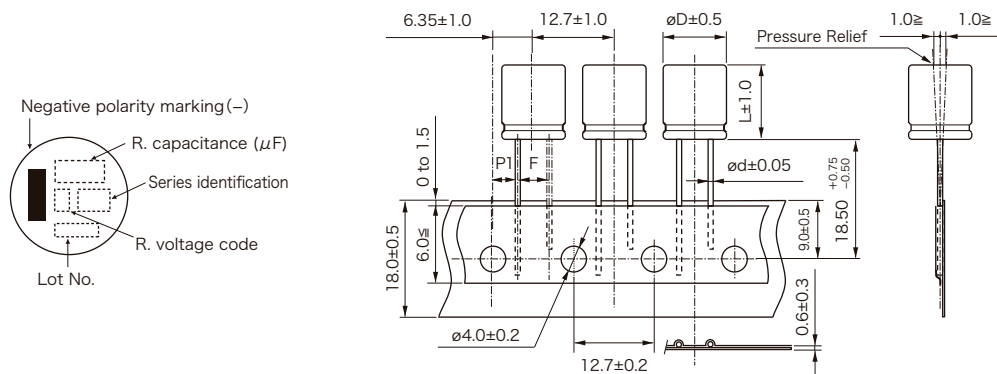

(Unit : mm)

R. voltage (V)	25	35	50	63
Code	E	V	H	J

Size code	φD	L	φd	F	P1
G12	10.0	11.7	0.8	5.0 ^{+0.8} _{-0.2}	3.85±0.50
G16	10.0	15.7	0.8	5.0 ^{+0.8} _{-0.2}	3.85±0.50

Characteristics list

Endurance 1 : 125 °C 4000 h
Endurance 2 : 135 °C 4000 h

Series	Rated voltage (V)	Capacitance (±20 %) (μF)	Case size (mm)			Size code	Specifications				Part number	Min. Packaging Qty (pcs)
			φD	L	φd		Ripple Current ※1 (mA rms)		ESR ※2 (mΩ)	tan δ ※3		
							Endurance 1 (+125 °C)	Endurance 2 (+135 °C)				Taping
ZS-A	25	470	10.0	11.7	0.8	G12	3500	2500	14	0.14	EEHAZS1E471B	500
		560	10.0	15.7	0.8	G16	4000	2900	11	0.14	EEHAZS1E561B	500
	35	330	10.0	11.7	0.8	G12	3500	2500	14	0.12	EEHAZS1V331B	500
		470	10.0	15.7	0.8	G16	4000	2900	11	0.12	EEHAZS1V471B	500
	50	150	10.0	11.7	0.8	G12	3200	2250	17	0.10	EEHAZS1H151B	500
		220	10.0	15.7	0.8	G16	3700	2600	13	0.10	EEHAZS1H221B	500
	63	100	10.0	11.7	0.8	G12	3000	2100	19	0.08	EEHAZS1J101B	500
		150	10.0	15.7	0.8	G16	3500	2400	15	0.08	EEHAZS1J151B	500

※1: Ripple current (100 kHz/ +125 °C)

※2: ESR (100 kHz/+20 °C)

※3: tan δ (120 Hz/ +20 °C)

◆Please refer to the P127 to 129 in this catalog for "Reflow conditions" and "Taping specifications".

Frequency correction factor for ripple current

Rated capacitance (C)	Frequency	100 Hz ≤ f < 200 Hz	200 Hz ≤ f < 300 Hz	300 Hz ≤ f < 500 Hz	500 Hz ≤ f < 1 kHz
100 μF ≤ C < 150 μF	Correction factor	0.15	0.20	0.25	0.30
150 μF ≤ C		0.15	0.25	0.25	0.30

Rated capacitance (C)	Frequency	1 kHz ≤ f < 2 kHz	2 kHz ≤ f < 3 kHz	3 kHz ≤ f < 5 kHz	5 kHz ≤ f < 10 kHz
100 μF ≤ C < 150 μF	Correction factor	0.40	0.45	0.55	0.60
150 μF ≤ C		0.45	0.50	0.60	0.65

Rated capacitance (C)	Frequency	10 kHz ≤ f < 15 kHz	15 kHz ≤ f < 20 kHz	20 kHz ≤ f < 30 kHz	30 kHz ≤ f < 40 kHz
100 μF ≤ C < 150 μF	Correction factor	0.70	0.75	0.80	0.80
150 μF ≤ C		0.75	0.80	0.85	0.85

Rated capacitance (C)	Frequency	40 kHz ≤ f < 50 kHz	50 kHz ≤ f < 100 kHz	100 kHz ≤ f < 500 kHz	500 kHz ≤ f < 1000 kHz
100 μF ≤ C < 150 μF	Correction factor	0.85	0.90	1.00	1.00
150 μF ≤ C		0.85	0.90	1.00	1.00

SP-Cap

Guidelines and Precautions
Mounting specifications
Packing specifications

Selection guide

Surface mount type

Catalog EOL models

POSCAP

Guidelines and Precautions
Mounting specifications
Packing specifications

Selection guide

Surface mount type

Catalog Deletion models

Catalog EOL models

OS-CON

Guidelines and Precautions
Mounting specifications
Packing specifications

Selection guide

Surface mount type

Radial lead type

Catalog EOL models

Hybrid

Guidelines and Precautions
Mounting specifications
Packing specifications

Line-up
Series system diagram
Products list

ZA
ZC
ZK
ZKU
ZT
ZS
ZSU
ZU
ZE
ZF
ZA-A
ZC-A
ZK-A
ZKU-A
ZT-A
ZS-A
ZSU-A
ZE-A
ZF-A



Endurance : 4000 h at 125 °C

Large capacitance compared with ZS series

Taping products for automatic insertion

AEC-Q200 compliant

RoHS compliant

SP-Cap

Guidelines and Precautions
Mounting specifications
Packing specifications

Selection guide

Surface mount type

Catalog EOL models

POSCAP

Guidelines and Precautions
Mounting specifications
Packing specifications

Selection guide

Surface mount type

Catalog Deletion models

Catalog EOL models

OS-CON

Guidelines and Precautions
Mounting specifications
Packing specifications

Selection guide

Surface mount type

Radial lead type

Catalog EOL models

Hybrid

Guidelines and Precautions
Mounting specifications
Packing specifications

Line-up

Series system diagram
Products list

- ZA
- ZC
- ZK
- ZKU
- ZT
- ZS
- ZSU**
- ZU
- ZE
- ZF

Surface mount type

Radial lead type

ZSU-A

ZE-A

ZF-A

Specifications

Items	Specifications	
Size code	G12	G16
Category temperature range	-55 °C to +125 °C	
Rated voltage range	25 V to 63 V	
Nominal capacitance range	120 μF to 680 μF	180 μF to 1000 μF
Capacitance tolerance	±20 % (120 Hz/+20 °C)	
DC leakage current	I ≤ 0.01 CV (μA), 2 minutes after reaching rated voltage, 20 °C *CV = (Capacitance in μF) x (Rated voltage in V)	
Dissipation factor (tan δ)	Please see the attached characteristics list	
Surge voltage (V)	Rated voltage x 1.25 (15 °C to 35 °C)	
Endurance	+125 °C±2 °C, 4000 h, apply the rated ripple current without exceeding the rated voltage.	
	Capacitance change	Within ±30% of the initial value
	Dissipation factor (tan δ)	≤ 200 % of the initial limit
	E.S.R.	≤ 200 % of the initial limit
	Leakage current	Within the initial limit
ESR after endurance (Ω / 100 kHz) (-40 °C)	Size code	
	G12	G16
	0.3	0.3
Shelf life	After storage for 1000 hours at +125 °C±2 °C with no voltage applied and then being stabilized at +20°C, capacitors shall meet the limits specified in endurance. (With voltage treatment)	
Damp heat (Load)	+85 °C ± 2 °C, 85 % to 90 % RH, 2000 h, rated voltage applied	
	Capacitance change	Within ±30% of the initial value
	Dissipation factor (tan δ)	≤ 200 % of the initial limit
	E.S.R.	≤ 200 % of the initial limit
Leakage current	Within the initial limit	
Resistance to soldering heat	After flow soldering and then being stabilized at +20°C, capacitors shall meet the following limits.	
	Capacitance change	Within ±10% of the initial value
	Dissipation factor (tan δ)	Within the initial limit
Leakage current	Within the initial limit	

Marking and Dimensions

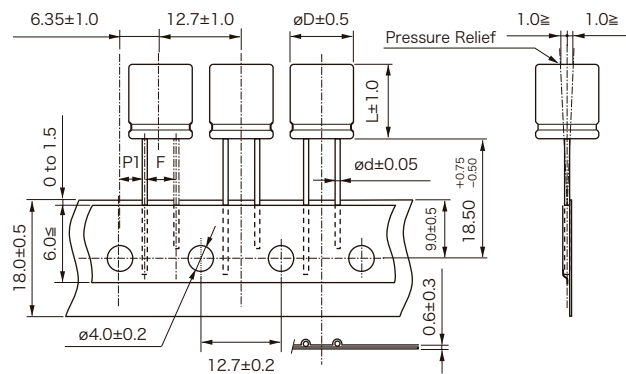
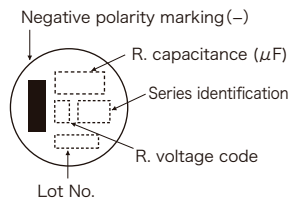

(Unit : mm)

R. voltage (V)	25	35	50	63
Code	E	V	H	J

Size code	φD	L	φd	F	P1
G12	10.0	11.7	0.8	5.0 ^{+0.8} / _{-0.2}	3.85±0.50
G16	10.0	15.7	0.8	5.0 ^{+0.8} / _{-0.2}	3.85±0.50

Characteristics list

Endurance : 125 °C 4000 h

Series	Rated voltage (V)	Capacitance (±20 %) (μF)	Case size (mm)			Size code	Specifications			Part number	Min. Packaging Qty (pcs)	
			φD	L	φd		Ripple Current ※1 (mA rms)	ESR ※2 (mΩ)	tan δ ※3		Taping	
ZSU-A	25	680	10.0	11.7	0.8	G12	3500	14	0.14	EEHAZSE681UB	500	
		1000	10.0	15.7	0.8	G16	4000	11	0.14	EEHAZSE102UB	500	
	35	470	10.0	11.7	0.8	G12	3500	14	0.12	EEHAZSV471UB	500	
		680	10.0	15.7	0.8	G16	4000	11	0.12	EEHAZSV681UB	500	
	50	180	10.0	11.7	0.8	G12	3200	17	0.10	EEHAZSH181UB	500	
		270	10.0	15.7	0.8	G16	3700	13	0.10	EEHAZSH271UB	500	
	63	120	10.0	11.7	0.8	G12	3000	19	0.08	EEHAZSJ121UB	500	
		180	10.0	15.7	0.8	G16	3500	15	0.08	EEHAZSJ181UB	500	

※1: Ripple current (100 kHz/ +125 °C)

※2: ESR (100 kHz/+20 °C)

※3: tan δ (120 Hz/ +20 °C)

◆Please refer to the P127 to 129 in this catalog for "Reflow conditions" and "Taping specifications".

Frequency correction factor for ripple current

Rated capacitance (C)	Frequency (f)	100 Hz ≤ f < 120 Hz	120 Hz ≤ f < 200 Hz	200 Hz ≤ f < 300 Hz	300 Hz ≤ f < 500 Hz
120 μF ≤ C	Correction factor	0.15	0.20	0.25	0.30

Rated capacitance (C)	Frequency (f)	500 Hz ≤ f < 1 kHz	1 kHz ≤ f < 2 kHz	2 kHz ≤ f < 3 kHz	3 kHz ≤ f < 5 kHz
120 μF ≤ C	Correction factor	0.40	0.50	0.60	0.65

Rated capacitance (C)	Frequency (f)	5 kHz ≤ f < 10 kHz	10 kHz ≤ f < 15 kHz	15 kHz ≤ f < 20 kHz	20 kHz ≤ f < 30 kHz
120 μF ≤ C	Correction factor	0.70	0.75	0.80	0.85

Rated capacitance (C)	Frequency (f)	30 kHz ≤ f < 50 kHz	50 Hz ≤ f < 100 Hz	100 Hz ≤ f < 500 Hz	500 Hz ≤ f < 1000 Hz
120 μF ≤ C	Correction factor	0.85	0.90	1.00	1.00

Design and specifications are each subject to change without notice. Ask factory for the current technical specifications before purchase and/or use.
Should a safety concern arise regarding this product, please be sure to contact us immediately.

SP-Cap

Guidelines and Precautions
Mounting specifications
Packing specifications

Selection guide

Surface mount type

Catalog EOL models

POSCAP

Guidelines and Precautions
Mounting specifications
Packing specifications

Selection guide

Surface mount type

Catalog Deletion models

Catalog EOL models

OS-CON

Guidelines and Precautions
Mounting specifications
Packing specifications

Selection guide

Surface mount type

Radial lead type

Catalog EOL models

Hybrid

Guidelines and Precautions
Mounting specifications
Packing specifications

Line-up
Series system diagram

Selection guide	Products list
Surface mount type	ZA
	ZC
	ZK
	ZKU
	ZT
	ZS
	ZSU
	ZU
	ZE
	ZF
Radial lead type	ZA-A
	ZC-A
	ZK-A
	ZKU-A
	ZT-A
ZS-A	
ZSU-A	
ZE-A	
ZF-A	

Design and specifications are each subject to change without notice. Ask factory for the current technical specifications before purchase and/or use.
Should a safety concern arise regarding this product, please be sure to contact us immediately.



Endurance : 2000 h at 145 °C (High temperature / Long life)

Taping products for automatic insertion

AEC-Q200 compliant

RoHS compliant

SP-Cap

Guidelines and Precautions
Mounting specifications
Packing specifications

Selection guide

Surface mount type

Catalog EOL models

POSCAP

Guidelines and Precautions
Mounting specifications
Packing specifications

Selection guide

Surface mount type

Catalog Deletion models

Catalog EOL models

OS-CON

Guidelines and Precautions
Mounting specifications
Packing specifications

Selection guide

Surface mount type

Radial lead type

Catalog EOL models

Hybrid

Guidelines and Precautions
Mounting specifications
Packing specifications

Line-up
Series system diagram
Products list

- ZA
- ZC
- ZK
- ZKU
- ZT
- ZS
- ZSU
- ZU
- ZE
- ZF

Surface mount type

Radial lead type

Specifications

Items	Specifications	
Size code	F	G
Category temperature range	-55 °C to +145 °C	
Rated voltage range	25 V to 63 V	
Nominal capacitance range	33 μF to 220 μF	56 μF to 330 μF
Capacitance tolerance	±20 % (120 Hz/+20 °C)	
Leakage current	I ≤ 0.01 CV (μA), 2 minutes after reaching rated voltage, 20 °C *CV = (Capacitance in μF) x (Rated voltage in V)	
Dissipation factor(tanδ)	Please see the attached characteristics list	
Surge voltage(V)	Rated voltage × 1.25 (15 °C to 35 °C)	
Endurance 1	+145 °C±2 °C, 2000 h, apply the rated ripple current without exceeding the rated voltage.	
	Capacitance change	Within ±30% of the initial value
	tan δ	≤ 200 % of the initial limit
	E.S.R.	≤ 200 % of the initial limit
Endurance 2	+135 °C±2 °C, 4000 h, apply the rated ripple current without exceeding the rated voltage.	
	Capacitance change	Within ±30% of the initial value
	tan δ	≤ 200 % of the initial limit
	E.S.R.	≤ 300 % of the initial limit
Shelf life	After storage for 1000 hours at +145 °C±2 °C with no voltage applied and then being stabilized at +20°C, capacitors shall meet the limits specified in endurance. (With voltage treatment)	
	+85 °C±2 °C, 85 % to 90 % RH, 2000 h, rated voltage applied.	
	Capacitance change	Within ±30% of the initial value
	tan δ	≤ 200 % of the initial limit
Damp heat (Load)	After storage for 1000 hours at +145 °C±2 °C with no voltage applied and then being stabilized at +20°C, capacitors shall meet the limits specified in endurance. (With voltage treatment)	
	+85 °C±2 °C, 85 % to 90 % RH, 2000 h, rated voltage applied.	
	Capacitance change	Within ±30% of the initial value
	tan δ	≤ 200 % of the initial limit
Resistance to soldering heat	After flow soldering and then being stabilized at +20 °C, capacitors shall meet the following limits.	
	Capacitance change	Within ±10% of the initial value
	tanδ	Within the initial limit
	Leakage current	Within the initial limit

Marking and Dimensions

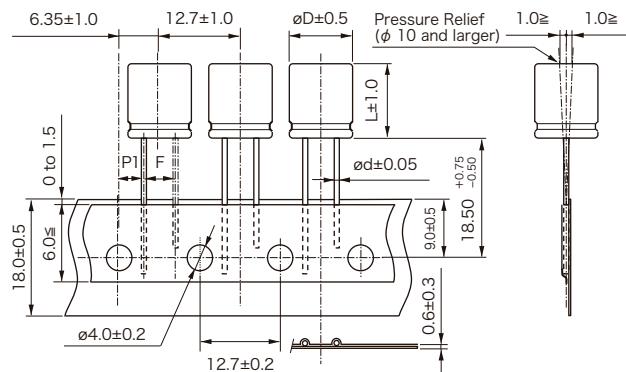
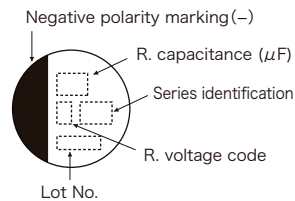

(Unit : mm)

R. voltage (V)	25	35	50	63
Code	E	V	H	J

Size code	φD	L	φd	F	P1
F	8.0	9.5	0.6	3.5±0.5	4.60±0.50
G	10.0	9.5	0.6	5.0 ^{+0.8} _{-0.2}	3.85±0.50

Characteristics list

Endurance 1: 145 °C 2000 h
Endurance 2: 135 °C 4000 h

Series	Rated voltage (V)	Capacitance (±20%) (μF)	Case size (mm)			Size code	Specifications				Part number	Min. Packaging Qty (pcs)
			φD	L	φd		Ripple Current ※1 (mA rms)		ESR ※2 (mΩ)	tan δ ※3		Taping
							Endurance 1	Endurance 2				
ZE-A	25	220	8.0	9.5	0.6	F	700	1600	27	0.14	EEHAZE1E221B	1000
		330	10.0	9.5	0.6	G	900	2000	20	0.14	EEHAZE1E331B	500
	35	150	8.0	9.5	0.6	F	700	1600	27	0.12	EEHAZE1V151B	1000
		270	10.0	9.5	0.6	G	900	2000	20	0.12	EEHAZE1V271B	500
	50	68	8.0	9.5	0.6	F	600	1250	30	0.10	EEHAZE1H680B	1000
		100	10.0	9.5	0.6	G	800	1600	28	0.10	EEHAZE1H101B	500
	63	33	8.0	9.5	0.6	F	600	1100	40	0.08	EEHAZE1J330B	1000
		56	10.0	9.5	0.6	G	800	1400	30	0.08	EEHAZE1J560B	500
			82	10.0	9.5		0.6	800	1400	30	0.08	EEHAZE1J820B

※1: Ripple current (100 kHz/+145 °C or +135 °C)

※2: ESR (100 kHz/+20 °C)

※3: tan δ (120 Hz/+20 °C)

◆Please refer to the P127 to 129 in this catalog for "Reflow conditions" and "Taping specifications".

Frequency correction factor for ripple current

Rated capacitance (C)	Frequency	100 Hz ≤ f < 200 Hz	200 Hz ≤ f < 300 Hz	300 Hz ≤ f < 500 Hz	500 Hz ≤ f < 1 kHz
C < 47 μF	Correction factor	0.10	0.10	0.15	0.20
47 μF ≤ C < 150 μF		0.15	0.20	0.25	0.30
150 μF ≤ C		0.15	0.25	0.25	0.30

Rated capacitance (C)	Frequency	1 kHz ≤ f < 2 kHz	2 kHz ≤ f < 3 kHz	3 kHz ≤ f < 5 kHz	5 kHz ≤ f < 10 kHz
C < 47 μF	Correction factor	0.30	0.40	0.45	0.50
47 μF ≤ C < 150 μF		0.40	0.45	0.55	0.60
150 μF ≤ C		0.45	0.50	0.60	0.65

Rated capacitance (C)	Frequency	10 kHz ≤ f < 15 kHz	15 kHz ≤ f < 20 kHz	20 kHz ≤ f < 30 kHz	30 kHz ≤ f < 40 kHz
C < 47 μF	Correction factor	0.60	0.65	0.70	0.75
47 μF ≤ C < 150 μF		0.70	0.75	0.80	0.80
150 μF ≤ C		0.75	0.80	0.85	0.85

Rated capacitance (C)	Frequency	40 kHz ≤ f < 50 kHz	50 kHz ≤ f < 100 kHz	100 kHz ≤ f < 500 kHz	500 kHz ≤ f < 1000 kHz
C < 47 μF	Correction factor	0.80	0.85	1.00	1.05
47 μF ≤ C < 150 μF		0.85	0.90	1.00	1.00
150 μF ≤ C		0.85	0.90	1.00	1.00

After endurance ESR (100 kHz, -40 °C)

Size code	F	G
ESR (Ω)	0.4	0.3

SP-Cap

Guidelines and Precautions
Mounting specifications
Packing specifications

Selection guide

Surface mount type

Catalog EOL models

POSCAP

Guidelines and Precautions
Mounting specifications
Packing specifications

Selection guide

Surface mount type

Catalog Deletion models

Catalog EOL models

OS-CON

Guidelines and Precautions
Mounting specifications
Packing specifications

Selection guide

Surface mount type

Radial lead type

Catalog EOL models

Hybrid

Guidelines and Precautions
Mounting specifications
Packing specifications

Line-up
Series system diagram
Products list

ZA
ZC
ZK
ZKU
ZT
ZS
ZSU
ZU
ZE
ZF
ZA-A
ZC-A
ZK-A
ZKU-A
ZT-A
ZS-A
ZSU-A
ZE-A
ZF-A



- Endurance : 1000 h at 150 °C (High temperature)
- High-withstand voltage (63 V)
- High temperature compared with ZC series
- Characteristics dependencies in low temperature and frequency are as small as polymer type.
- Taping products for automatic insertion
- RoHS compliant
- AEC-Q200 compliant

SP-Cap

Specifications

Items	Specifications	
Size code	F	G
Category temperature range	-55 °C to +150 °C	
Rated voltage range	25 V to 63 V	
Nominal capacitance range	33 μF to 150 μF	56 μF to 270 μF
Capacitance tolerance	±20 % (120 Hz / +20°C)	
DC leakage current	I ≤ 0.01 CV (μA), 2 minutes after reaching rated voltage, 20 °C *CV = (Capacitance in μF) x (Rated voltage in V)	
Dissipation factor (tan δ)	Please see the attached characteristics list	
Surge voltage (V)	Rated voltage x 1.25 (15 °C to 35 °C)	
Endurance	+150 °C ± 2 °C, 1000 h, apply the rated ripple current without exceeding the rated voltage.	
	Capacitance change	Within ±30% of the initial value
	Dissipation factor (tan δ)	≤ 200 % of the initial limit
	E.S.R.	≤ 200 % of the initial limit
	Leakage current	Within the initial limit
ESR after endurance (Ω / 100 kHz) (-40 °C)	Size code	
	F	G
	0.4	0.3
Shelf life	After storage for 1000 hours at +150 °C ± 2 °C with no voltage applied and then being stabilized at +20 °C, capacitors shall meet the limits specified in endurance. (With voltage treatment)	
Damp heat (Load)	+85 °C ± 2 °C, 85 % to 90 % RH, 2000 h, rated voltage applied	
	Capacitance change	Within ±30% of the initial value
	Dissipation factor (tan δ)	≤ 200 % of the initial limit
	E.S.R.	≤ 200 % of the initial limit
	Leakage current	Within the initial limit
Resistance to soldering heat	After flow soldering and then being stabilized at +20 °C, capacitors shall meet the following limits.	
	Capacitance change	Within ±10% of the initial value
	tan δ	Within the initial limit
	Leakage current	Within the initial limit

Marking and Dimensions

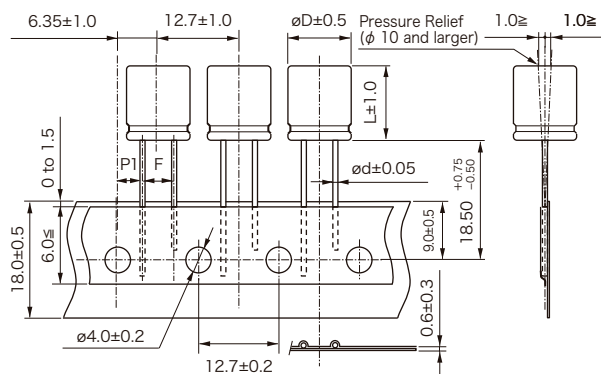
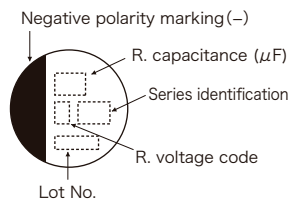

(Unit:mm)

R. voltage (V)	25	35	50	63
Code	E	V	H	J

Size code	φD	L	φd	F	P1
F	8.0	9.5	0.6	3.5±0.5	4.60±0.50
G	10.0	9.5	0.6	5.0 ^{+0.8} _{-0.2}	3.85±0.50

- Guidelines and Precautions
- Mounting specifications
- Packing specifications
- Selection guide
- Surface mount type
- Catalog EOL models
- POSCAP
- Guidelines and Precautions
- Mounting specifications
- Packing specifications
- Selection guide
- Surface mount type
- Catalog Deletion models
- Catalog EOL models
- OS-CON
- Guidelines and Precautions
- Mounting specifications
- Packing specifications
- Selection guide
- Surface mount type
- Radial lead type
- Catalog EOL models
- Hybrid
- Guidelines and Precautions
- Mounting specifications
- Packing specifications
- Line-up
- Series system diagram
- Products list
- ZA
- ZC
- ZK
- ZKU
- ZT
- ZS
- ZSU
- ZU
- ZE
- ZF
- ZA-A
- ZC-A
- ZK-A
- ZKU-A
- ZT-A
- ZS-A
- ZSU-A
- ZE-A
- ZF-A
- Surface mount type
- Radial lead type

Characteristics list

Endurance : 150 °C 1000 h

Series	Rated voltage (V)	Capacitance (±20%) (μF)	Case size (mm)		Size code	Specifications			Part number	Min. Packaging Qty (pcs)
			φD	L		Ripple Current ※1 (mA rms)	ESR ※2 (mΩ)	tan δ ※3		Taping
ZF-A	25	150	8.0	9.5	F	800	27	0.14	EEHAZF1E151B	1000
		270	10.0	9.5	G	1000	20	0.14	EEHAZF1E271B	500
	35	100	8.0	9.5	F	770	30	0.12	EEHAZF1V101B	1000
		150	10.0	9.5	G	950	23	0.12	EEHAZF1V151B	500
	50	56	8.0	9.5	F	700	35	0.10	EEHAZF1H560B	1000
		100	10.0	9.5	G	900	28	0.10	EEHAZF1H101B	500
	63	33	8.0	9.5	F	650	40	0.08	EEHAZF1J330B	1000
		56	10.0	9.5	G	840	30	0.08	EEHAZF1J560B	500

※1: Ripple current (100 kHz / +150 °C)

※2: ESR (100 kHz / +20 °C)

※3: tan δ (120 Hz / +20 °C)

◆Please refer to the P127 to 129 in this catalog for "Reflow conditions" and "Taping specifications".

Frequency correction factor for ripple current

Rated capacitance (C)	Frequency (f)	100 Hz ≤ f < 200 Hz	200 Hz ≤ f < 300 Hz	300 Hz ≤ f < 500 Hz	500 Hz ≤ f < 1 kHz
C < 47 μF	Correction factor	0.10	0.10	0.15	0.20
47 μF ≤ C < 150 μF		0.15	0.20	0.25	0.30
150 μF ≤ C		0.15	0.25	0.25	0.30

Rated capacitance (C)	Frequency (f)	1 kHz ≤ f < 2 kHz	2 kHz ≤ f < 3 kHz	3 kHz ≤ f < 5 kHz	5 kHz ≤ f < 10 kHz
C < 47 μF	Correction factor	0.30	0.40	0.45	0.50
47 μF ≤ C < 150 μF		0.40	0.45	0.55	0.60
150 μF ≤ C		0.45	0.50	0.60	0.65

Rated capacitance (C)	Frequency (f)	10 kHz ≤ f < 15 kHz	15 kHz ≤ f < 20 kHz	20 kHz ≤ f < 30 kHz	30 kHz ≤ f < 40 kHz
C < 47 μF	Correction factor	0.60	0.65	0.70	0.75
47 μF ≤ C < 150 μF		0.70	0.75	0.80	0.80
150 μF ≤ C		0.75	0.80	0.85	0.85

Rated capacitance (C)	Frequency (f)	40 kHz ≤ f < 50 kHz	50 kHz ≤ f < 100 kHz	100 kHz ≤ f < 500 kHz	500 kHz ≤ f
C < 47 μF	Correction factor	0.80	0.85	1.00	1.05
47 μF ≤ C < 150 μF		0.85	0.90	1.00	1.00
150 μF ≤ C		0.85	0.90	1.00	1.00

SP-Cap

Guidelines and Precautions
Mounting specifications
Packing specifications

Selection guide

Surface mount type

Catalog EOL models

POSCAP

Guidelines and Precautions
Mounting specifications
Packing specifications

Selection guide

Surface mount type

Catalog Deletion models

Catalog EOL models

OS-CON

Guidelines and Precautions
Mounting specifications
Packing specifications

Selection guide

Surface mount type

Radial lead type

Catalog EOL models

Hybrid

Guidelines and Precautions
Mounting specifications
Packing specifications

Selection guide	Line-up
	Series system diagram
Surface mount type	Products list
	ZA
	ZC
	ZK
	ZKU
	ZT
	ZS
	ZSU
	ZU
	ZE
	ZF
	ZA-A
	ZC-A
ZK-A	
ZKU-A	
ZT-A	
ZS-A	
ZSU-A	
ZE-A	
ZF-A	

Safety Precautions

When using our products, no matter what sort of equipment they might be used for, be sure to confirm the applications and environmental conditions with our specifications in advance.

Panasonic
INDUSTRY

Panasonic
Device Solutions Business Division
Industry Co., Ltd.
1006 Kadoma, Kadoma City, Osaka
571-8506 Japan